

FLO-RITE-TEMP® 8120 & 8120DW

INSTANTANEOUS WATER HEATER

Flo-Rite-Temp® Instantaneous Steam/Water Heater is a shell & tube heat exchanger fitted with an integral control valve for water heating and temperature control.

The feed forward design instantly determines downstream system demand and directs cold water through the heat exchanger. Water is heated above legionella survival temperatures with constant pressure steam and then blended with a proportional amount of cold water to set point temperature.

Flo-Rite-Temp® Instantaneous Steam/Water Heaters are available with single wall or double wall heat exchangers in four standard sizes. A stainless steel construction option is available.



Flo-Rite-Temp® 8120 Single Wall Instantaneous Water Heater

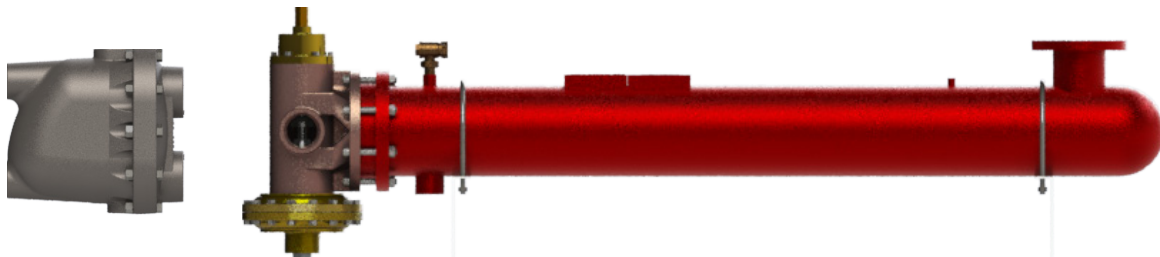

Flo-Rite-Temp® 8120DW Double Wall Instantaneous Water Heater

Designs, materials, weights, and performance ratings are approximate and subject to change without notice. Visit armstronginternational.com for the most up-to-date information.

FLO-RITE-TEMP® 8120 & 8120DW

TECHNICAL SPECIFICATIONS - SIZING

FRT8120 and FRT8120DW Water and Steam Capacities - Imperial Units									
Inlet Temperature	Set Temperature	Hot Water Capacities in GPM				Steam Capacities in lb/hr			
		Steam Pressure				Steam Pressure			
		2 psig	5 psig	10 psig	15 psig	2 psig	5 psig	10 psig	15 psig
40°F	120°F	142	145	145	145	5,680	6,160	6,760	7,160
	130°F	112	122	136	145	5,040	5,490	6,120	6,705
	140°F	88	97	109	120	4,400	4,850	5,450	6,000
	160°F	69	83	89	95	4,140	4,980	5,340	5,700
	180°F	43	47	52	59	3,010	3,290	3,640	4,130
50°F	120°F	145	145	145	145	5,740	6,090	6,580	7,035
	130°F	127	138	145	145	5,080	5,520	6,120	6,760
	140°F	99	108	121	134	4,455	4,860	5,445	6,030
	160°F	76	90	95	102	4,180	4,950	5,225	5,610
	180°F	49	55	63	72	3,185	3,575	4,095	4,680
60°F	130°F	145	145	145	145	5,110	5,565	6,090	6,510
	140°F	111	123	137	145	4,440	4,920	5,480	6,080
	160°F	85	99	104	115	4,250	4,950	5,200	5,750
	180°F	59	67	80	90	3,540	4,020	4,800	5,400

FRT8120 and FRT8120DW Water and Steam Capacities - Metric Units									
Inlet Temperature	Set Temperature	Hot Water Capacities in m³				Steam Capacities in kg/hr			
		Steam Pressure				Steam Pressure			
		0.14 bar	0.35 bar	0.7 bar	1 bar	0.14 bar	0.35 bar	0.7 bar	1 bar
4°C	49°C	32.2	32.9	32.9	32.9	2,576	2,794	3,066	3,248
	54°C	25.4	27.7	30.9	32.9	2,286	2,490	2,776	3,041
	60°C	20.0	22.0	24.7	27.2	1,996	2,200	2,472	2,722
	71°C	15.6	18.8	20.2	21.6	1,878	2,259	2,422	2,585
	82°C	9.7	10.7	11.8	13.4	1,365	1,492	1,651	1,873
50°C	49°C	32.2	32.2	32.2	32.2	2,603	2,762	2,985	3,191
	54°C	28.8	31.3	32.2	32.2	2,304	2,504	2,776	3,066
	60°C	22.5	24.5	27.5	30.4	2,021	2,204	2,470	2,735
	71°C	17.2	20.4	21.6	23.1	1,896	2,245	2,370	2,545
	82°C	11.1	12.5	14.3	16.3	1,445	1,622	1,857	2,123
60°C	54°C	32.2	32.2	32.2	32.2	2,318	2,524	2,762	2,953
	60°C	25.2	27.9	31.1	32.2	2,014	2,232	2,486	2,758
	71°C	19.3	22.5	23.6	26.1	1,928	2,245	2,359	2,608
	82°C	13.4	15.2	18.1	20.4	1,606	1,823	2,177	2,449

Designs, materials, weights, and performance ratings are approximate and subject to change without notice. Visit armstronginternational.com for the most up-to-date information.



FLO-RITE-TEMP® 8120 & 8120DW

TECHNICAL SPECIFICATIONS

General		
Ambient Temperature	Minimum Ambient Temperature: 35°F (2°C)	Maximum Ambient Temperature: 122°F (50°C)
Installation Environment	Suitable for indoor use only	
Materials		
FRT Control Valve	Bronze	
Heat Exchanger Shell	Carbon steel, ASTM SA-106, Gr. B, ASME "U" stamped with Type 316 stainless steel two-pass head	
Heat Exchanger Tube Bundle	Single Wall	Admiralty brass tubes; 5/8" OD x 16 BWG wall
	Double Wall	Copper tubes; 5/8" OD inner with 3/4" OD grooved outer
Heat Exchanger Tube Sheets	Single Wall	Lead-free brass
	Double Wall	Brass on water side; Steel on steam side
Tube Bundle End Cap (Single Wall ONLY)	Lead-free brass	
Connections		
Water Side	Cold Water Inlet	3" Class 150 Flange Connection
	Mixed Water Outlet	3" Class 150 Flange Connection
Steam Side	Steam Inlet	4" Class 150 Flange Connection
	Condensate Outlet	2" NPT Connections (Armstrong Steam Trap 20-JD8 F&T)
Pressures		
Water Inlet Supply Pressures	Maximum Water Pressure: 150 psig (10 barg)	Minimum Pressure: 20 psig (1.5 barg)
Steam Inlet Supply Pressures	Maximum Allowable Steam Pressure: 150 psig (10 barg)	
	Maximum Operating Steam Pressure: 15 psig (1 barg)	
Temperatures		
Control Range	+ / - 4°F (within 25' downstream during demand)	

Designs, materials, weights, and performance ratings are approximate and subject to change without notice. Visit armstronginternational.com for the most up-to-date information.



FLO-RITE-TEMP® 8120 & 8120DW

WRITTEN SPECIFICATIONS

Category: Steam to Water Heater with Shell and Tube Heat Exchanger

Type: Flo-Rite-Temp®

Model: FRT8120 and FRT8120DW

Part 1 - GENERAL

1.0 Flo-Rite-Temp® FRT8120 and FRT8120DW Overview

- 1.1 The assembly shall be a steam to water shell and tube heater.
 - 1.1.1 FRT8120 shall be of single wall construction with straight admiralty brass tubes expanded into naval brass tube sheets with a bolted end cover.
 - 1.1.2 FRT8120DW shall be of double wall construction with 5/8" copper inner tube, 3/4" ID grooved copper outer tube expanded into steel (steam side) and brass (water side) tube sheets.

Heat exchanger will be fixed on one end of the shell and free-floating on the opposite end designed and manufactured in accordance with ASME Code Section VIII.

2.0 FRT8120 and FRT8120DW Assembly

- 2.1 The assembly shall comprise of a shell and tube heat exchanger with industrial grade enamel paint, a brass control valve, and a Model 20JD8F+T steam trap.
- 2.2 Steam pressure on the system to be no more than 15 psig. Designed to generate 120 GPM with a 40°F entering cold water temperature, a 140°F mixed water set point utilizing 15 psig at a maximum of 6,000 lbs/hr.

3.0 FRT8120 and FRT8120DW shall have the following operational specifications:

- 3.1 +/- 4° F (2° C) water temperature control from zero-system demand to full system demand
- 3.2 Pressure drop not to exceed 10 psi at maximum flow
- 3.3 Operating steam pressure (constant) between 2-15 psig
- 3.4 Operating water pressure between 20-150 psig
- 3.5 Pressure-sensitive mixing valve is integrally mounted to shell and tube exchanger using feed-forward sensing
- 3.6 Pressure-sensitive mixing valve shall fail in the cold position in the event of diaphragm failures
- 3.7 1/4" domestic side pressure relief pop-off valve with 165 psig (11.4 barg) crack pressure, self-seating
- 3.8 Thermostatic air vent to vent the exchanger air on start-up
- 3.9 Inverted bucket steam trap for condensate return
- 3.10 Exchanger tubes:
 - 3.11.1 FRT8120: 16-gauge, 5/8" OD admiralty brass straight tubes expanded into naval brass tube sheets
 - 3.11.2 FRT8120DW: 5/8" copper inner tubes, 3/4" outer tubes expanded into steel / brass tube sheets
- 3.12 Carbon steel shell with 4" 150lb flange steam inlet and 2" condensate outlet connections

4.0 Warranty

- 4.1 Water heater assembly shall have a 2-year warranty from date of installation, but not longer than 27 months from date of shipment.
- 4.2 The tube bundle shall have a 10-year guarantee against failure caused by materials or workmanship provided by Armstrong but not against gasket failure or damage caused by corrosion, water hammer or lack of proper cleaning.

Designs, materials, weights, and performance ratings are approximate and subject to change without notice. Visit armstronginternational.com for the most up-to-date information.



APPROVAL

BY: _____ DATE: _____

- APPROVED, PROCEED WITH FABRICATION
- APPROVED AS NOTED, PROCEED WITH FABRICATION IN ACCORDANCE WITH COMMENTS
- DISAPPROVED, DO NOT FABRICATE

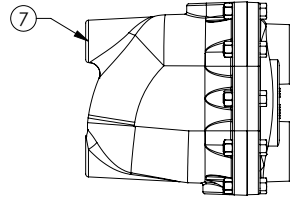
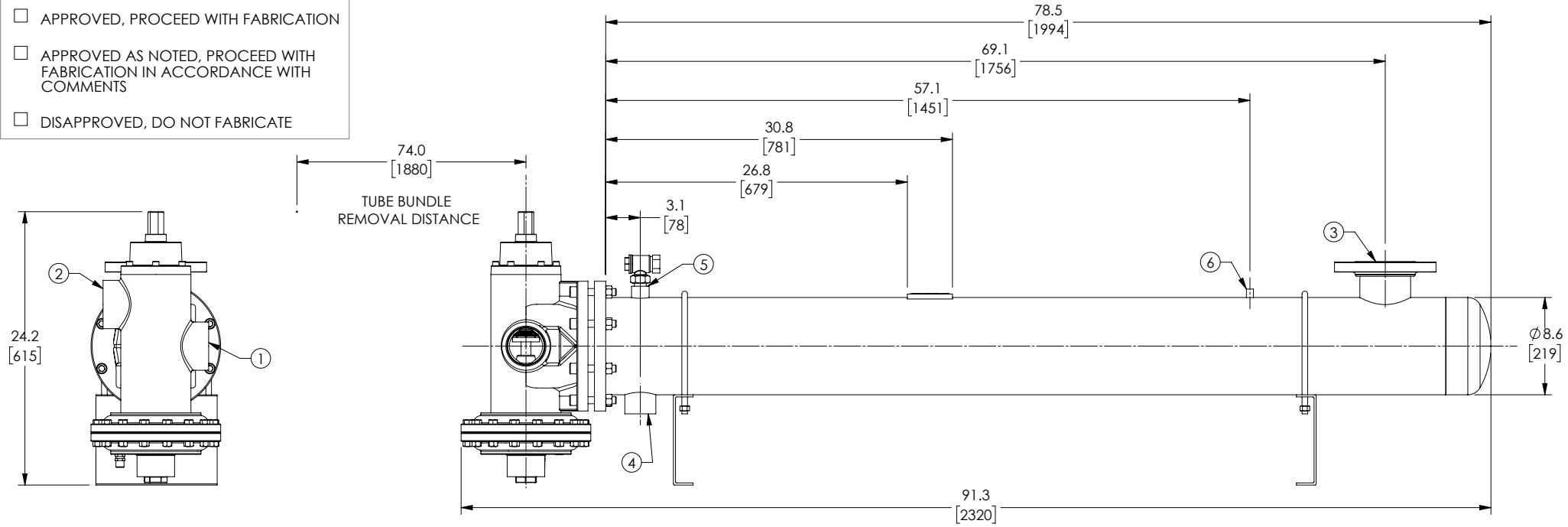

NOTE(S):

1. ARMSTRONG PART NUMBER : D58653
2. COMPLETE ASSEMBLY LEAD FREE COMPLIANT - THE WETTED SURFACE OF THIS PRODUCT CONTACTED BY CONSUMABLE WATER CONTAINS LESS THAN ONE QUARTER OF ONE PERCENT (0.25%) OF LEAD BY WEIGHT.

PROJECT NAME:		
TAG:		
ITEM	DESCRIPTION	CONNECTION
1	COLD WATER INLET	3" NPT
2	HOT WATER OUTLET	3" NPT
3	STEAM INLET	4" 150# ANSI(FLG)
4	CONDENSATE OUTLET	2" NPT
5	AIR VENT	3/4" NPT
6	PRESSURE GAUGE PORT	1/4" NPT
7	20-JD8 F&T	2" NPT
ITEM	MATERIAL	
	EXCHANGER SHELL MATL	CARBON STEEL
	EXCHANGER TUBE MATL	ADMIRALTY BRASS

DO NOT SCALE DRAWING TOLERANCES UNLESS OTHERWISE SPECIFIED	
DIMENSIONING ENGLISH [mm]	
FRACTIONAL	± 1/64
ANGULAR:	± 2
DECIMAL	.XXXX ± .0005
	.XX ± .005 .10
	.XX ± .015 .10
	.X ± .3

Armstrong

NAME	DATE
DRAWN RAJKUMAR	07/22/2015
RELEASED	

ARMSTRONG INTERNATIONAL Copyright © 2010 ARMSTRONG INTERNATIONAL, INC.	
FRT8120 W/SS AND TRAP LF	
MATERIAL	SHEET 1 OF 1
CN57167	REV C DWG. SALES

APPROVAL

- BY: _____ DATE: _____
- APPROVED, PROCEED WITH FABRICATION
- APPROVED AS NOTED, PROCEED WITH FABRICATION IN ACCORDANCE WITH COMMENTS
- DISAPPROVED, DO NOT FABRICATE

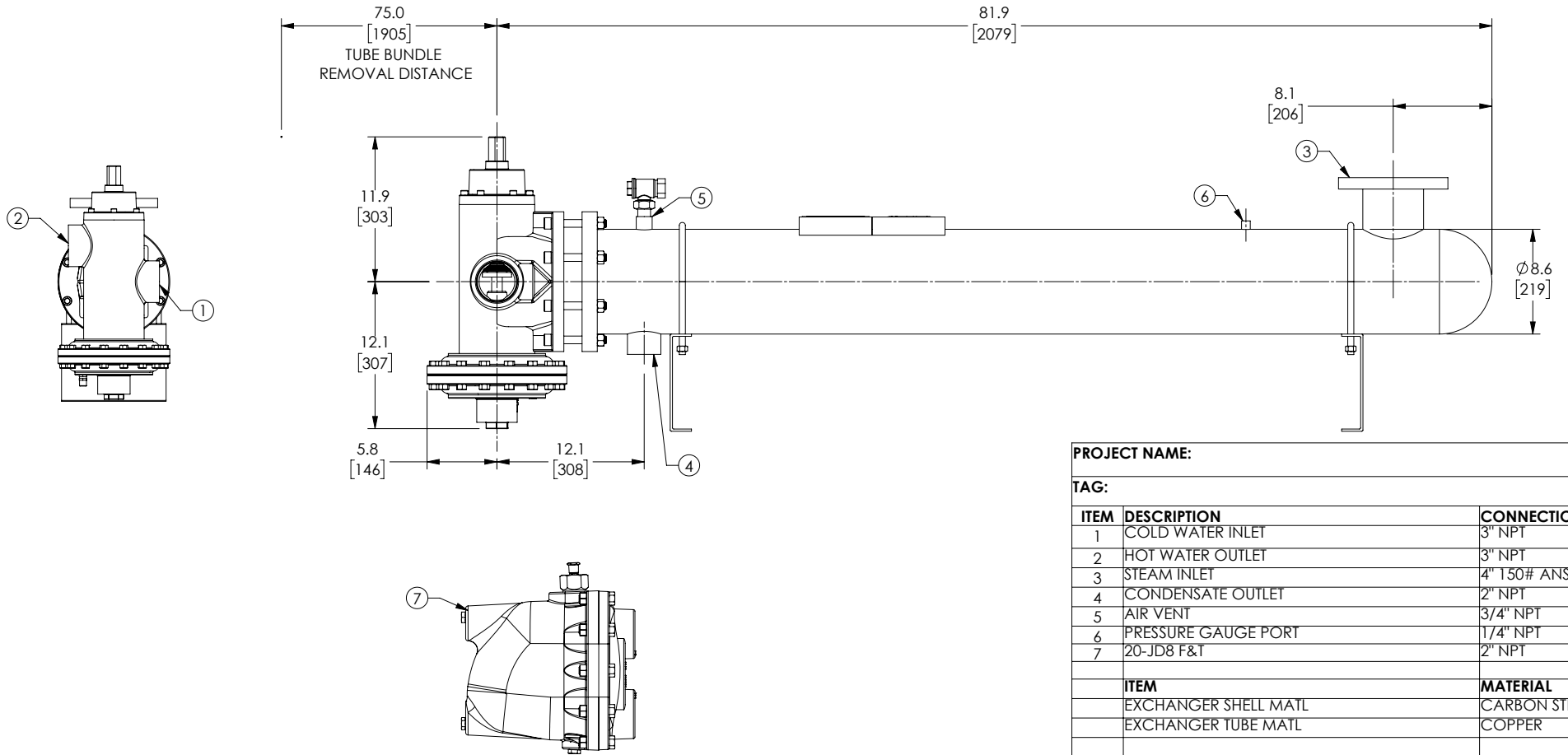

PROJECT NAME:

TAG:

ITEM	DESCRIPTION	CONNECTION
1	COLD WATER INLET	3" NPT
2	HOT WATER OUTLET	3" NPT
3	STEAM INLET	4" 150# ANSI (FLG)
4	CONDENSATE OUTLET	2" NPT
5	AIR VENT	3/4" NPT
6	PRESSURE GAUGE PORT	1/4" NPT
7	20-JD8 F&T	2" NPT
	ITEM	MATERIAL
	EXCHANGER SHELL MATL	CARBON STEEL
	EXCHANGER TUBE MATL	COPPER

NOTE(S):

1. ARMSTRONG PART NUMBER : D58654
2. COMPLETE ASSEMBLY LEAD FREE COMPLIANT - THE WETTED SURFACE OF THIS PRODUCT CONTACTED BY CONSUMABLE WATER CONTAINS LESS THAN ONE QUARTER OF ONE PERCENT (0.25%) OF LEAD BY WEIGHT.

DO NOT SCALE DRAWING
TOLERANCES UNLESS OTHERWISE SPECIFIED
DIMENSIONING ENGLISH [mm]

FRACTIONAL ± 1/64
ANGULAR: ± 2

DECIMAL	IN.	MM
.XXX	± .0005	----
.XX	± .005	.10
.X	± .015	.10
	-----	.3

NAME: RAJKUMAR
DATE: 07/22/2015

ARMSTRONG INTERNATIONAL
Copyright © 2010 ARMSTRONG INTERNATIONAL, INC.
FR18120DW W/SS AND TRAP LF

MATERIAL: CN74104
REV F DWG. SALES

SHEET 1 OF 1