

PIPING AND COMPONENTS
HIDDEN TO SHOW CONNECTIONS

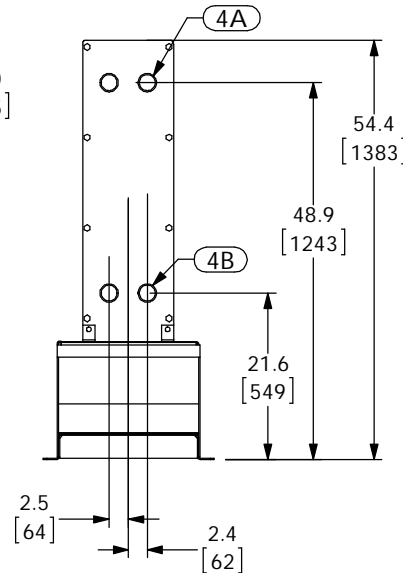

APPROVAL

BY: _____ DATE: _____

- APPROVED, PROCEED WITH FABRICATION
- APPROVED AS NOTED, PROCEED WITH FABRICATION IN ACCORDANCE WITH COMMENTS
- DISAPPROVED, DO NOT FABRICATE

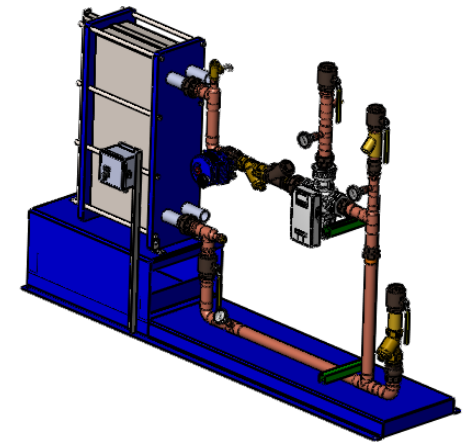

**DIGITAL FLO BOILER WATER/WATER PLATE &
FRAME HEAT EXCHANGER SINGLE WALL**

PROJECT NAME :

TAG :

ITEM	DESCRIPTION	CONNECTION
1	COLD WATER INLET	2" NPT
2	MIXED WATER OUTLET	2" NPT
3	RECIRC WATER INLET	1-1/2" NPT
4A	PRIMARY(BOILER) INLET	2" NPT
4B	PRIMARY(BOILER) OUTLET	2" NPT
5	ELECTRICAL PANEL	110VAC @ 0.7A
6	DRV80	3" NPT
7	N.C. ACTUATED BALL VALVE SAFETY SHUT OFF	2" NPT
8	THERMOMETER (3)	
9	CIP CONNECTION (2)	1" NPT
10	SRV(PRESSURE) PIPE TO DRAIN	1" NPT
11	SRV(CONNECTION FOR USER SUPPLIED T&P)	3/4" NPT
ITEM	MATERIAL	
PIPING	COPPER TYPE "L"	
EXCHANGER PLATE MATL.	T316L SS	
EXCHANGER GASKET MATL.	NITRILE	

NOTE(S):

- ALL DIMENSIONS +/- .5[13] UNLESS OTHERWISE SHOWN.
- COMPLETE ASSEMBLY LEAD FREE COMPLIANT - THE WETTED SURFACE OF THIS PRODUCT CONTACTED BY CONSUMABLE WATER CONTAINS LESS THAN ONE QUARTER OF ONE PERCENT (0.25%) OF LEAD BY WEIGHT.
- PACKAGE INCLUDES ALL REQUIRED INLET CHECK VALVES AND STRAINERS ON DOMESTIC SIDE.
- DRV, SAFETY SHUT OFF AND ELECTRICAL PANEL ARE PREWIRED TO PROVIDE A SINGLE ELECTRICAL LANDING POINT AT THE PANEL.

DO NOT SCALE DRAWING	
TOLERANCES UNLESS OTHERWISE SPECIFIED	
DIMENSIONING ENGLISH [mm]	
FRACTIONAL	± 1/64
ANGULAR	± 2
DECIMAL	XXX ± .0005
	XXX ± .005
	XX ± .015
	X ± .03

		NAME	DATE
		CFG	02/26/2013
RELEASED	SALES		

ARMSTRONG INTERNATIONAL Copyright © 2010 ARMSTRONG INTERNATIONAL, INC.	
DF65W50 2 NPT 2 NPT 1-1/2 NPT CPR	
CONFIG# (C-XXXXXX)	
MATERIAL	SHEET 1 OF 1
REV	DWG: D5XXXXX