

APPROVAL

BY: _____ DATE: _____

APPROVED, PROCEED WITH FABRICATION

APPROVED AS NOTED, PROCEED WITH FABRICATION IN ACCORDANCE WITH COMMENTS

DISAPPROVED, DO NOT FABRICATE

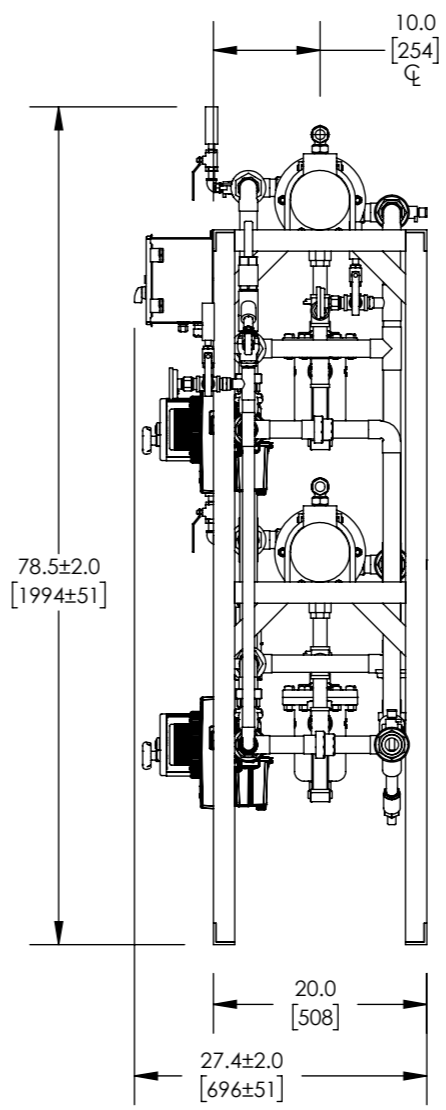
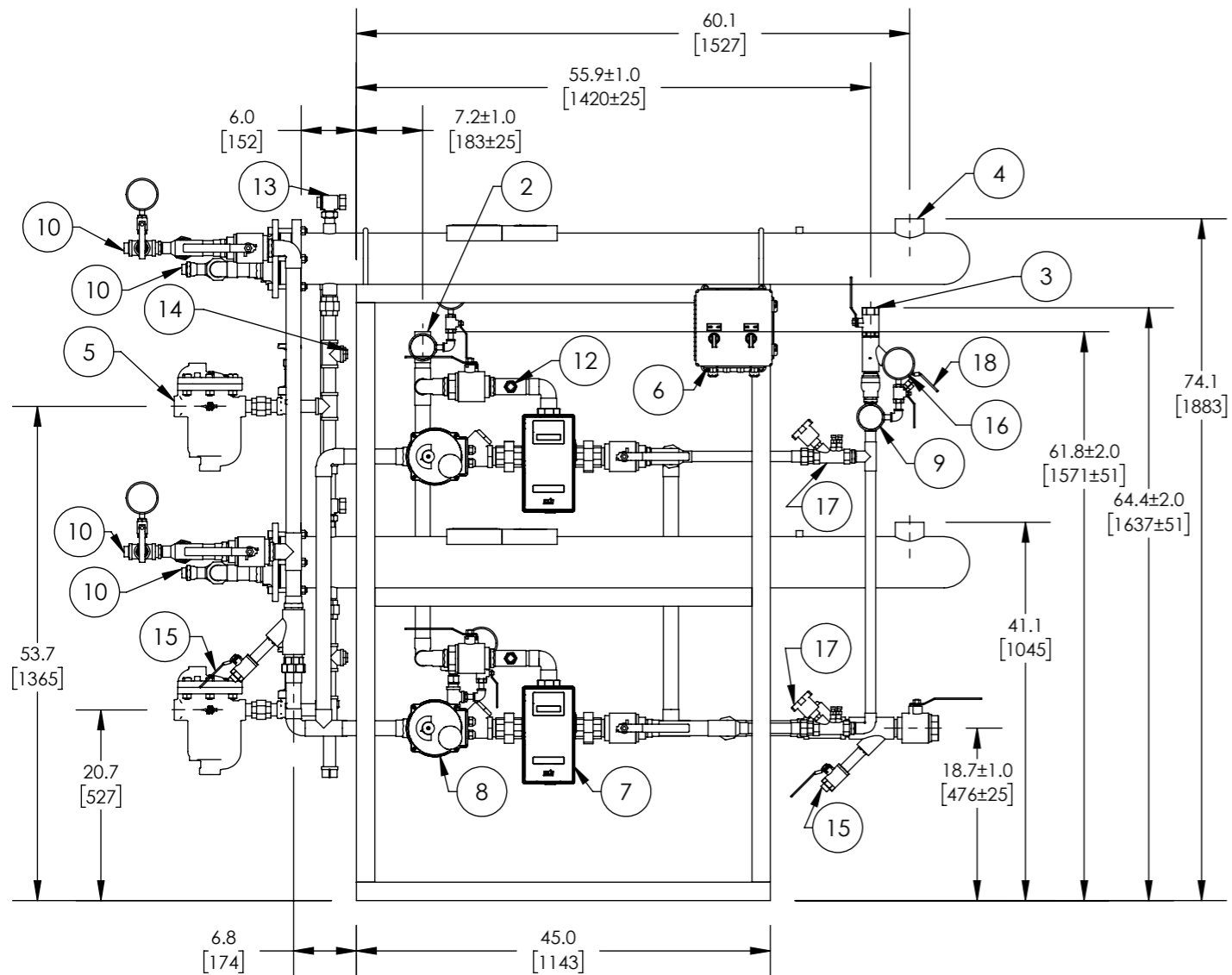
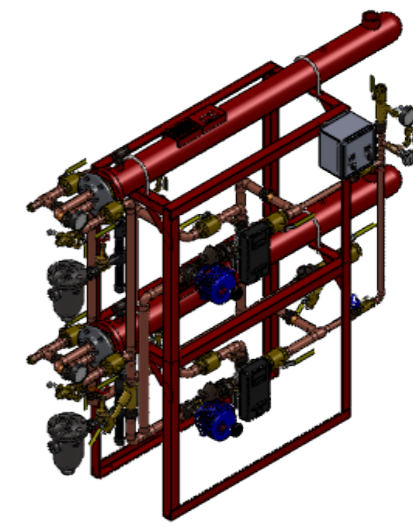

PROJECT NAME:

TAG:

ITEM	DESCRIPTION	CONNECTION
1	COLD WATER INLET	1-1/2" NPT
2	MIXED WATER OUTLET	1-1/2" SWT
3	RECIRC WATER INLET	1" NPT
4	STEAM INLET (2)	2-1/2" NPT
5	CONDENSATE OUTLET (2)	1" NPT 8131B
6	ELECTRICAL PANEL	110VAC @1.4A
7	DRV40 (2)	1-1/2" NPT
8	N.C. ACTUATED BALL VALVE SAFETY SHUT OFF (2)	1-1/2" NPT
9	THERMOMETER (3)	1/2" NPT
10	CIP CONNECTION (4)	1" NPT
11	SRV (PRESSURE) PIPE TO DRAIN (2)	1/4" NPT
12	SRV (CONNECTION FOR USER SUPPLIED T&P) (2)	3/4" NPT
13	AIR VENT (2)	3/4" NPT
14	VACUUM BREAKER (2)	1/2" NPT
15	BLOWDOWN (2)	3/4" NPT
16	PRESSURE GAUGE(5)	1/4" NPT
17	BALANCING VALVE (2)	1" NPT
18	BLOWDOWN	1/2" NPT

ITEM	MATERIAL
PIPING	COPPER TYPE "L"
EXCHANGER SHELL MATL.	CARBON STEEL
EXCHANGER TUBE MATL.	COPPER

NOTE(S):

- ALL DIMENSIONS +/-0.5 [13] UNLESS OTHERWISE SHOWN.
- COMPLETE ASSEMBLY LEAD FREE COMPLIANT - THE WETTED SURFACE OF THIS PRODUCT CONTACTED BY CONSUMABLE WATER CONTAINS LESS THAN ONE QUARTER OF ONE PERCENT (0.25%) OF LEAD BY WEIGHT.
- PACKAGE INCLUDES ALL REQUIRED INLET CHECK VALVES AND STRAINERS ON DOMESTIC SIDE.
- DRV, SAFETY SHUT OFF AND ELECTRICAL PANEL ARE PREWIRED TO PROVIDE A SINGLE ELECTRICAL LANDING POINT AT THE PANEL.

DO NOT SCALE DRAWING
TOLERANCES UNLESS OTHERWISE SPECIFIED
DIMENSIONING ENGLISH [mm]
FRACTIONAL ± 1/64
ANGULAR: ± 2

DECIMAL	.XXXX ± .0005	IN.	MM
	.XXX ± .005		.010
	.XX ± .015		.10
	.X		.3

NAME	DATE
CFG	5/18/2015

DRAWN: CFG
RELEASED: _____

ARMSTRONG INTERNATIONAL
Copyright © 2010 ARMSTRONG INTERNATIONAL, INC.

DF535DWP40-40

MATERIAL	SHEET 1 OF 1
REV	SALES