

APPROVAL

BY: _____ DATE: _____

- APPROVED, PROCEED WITH FABRICATION
- APPROVED AS NOTED, PROCEED WITH FABRICATION IN ACCORDANCE WITH COMMENTS
- DISAPPROVED, DO NOT FABRICATE

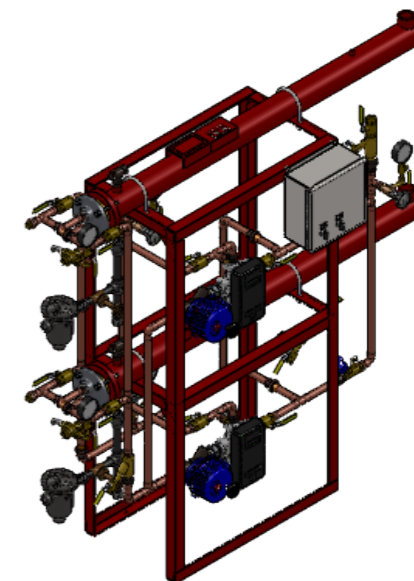

PROJECT NAME:

TAG:

ITEM	DESCRIPTION	CONNECTION
1	COLD WATER INLET	1" NPT
2	MIXED WATER OUTLET	1" SWT
3	RECIRC WATER INLET	1" NPT
4	STEAM INLET (2)	2" NPT
5	CONDENSATE OUTLET (2)	3/4" NPT 812IB
6	ELECTRICAL PANEL	110VAC @2A
7	DRV40 (2)	1-1/2" NPT
8	N.C. ACTUATED BALL VALVE SAFETY SHUT OFF (2)	1" NPT
9	THERMOMETER (3)	1/2" NPT
10	CIP CONNECTION (4)	1" NPT
11	SRV (PRESSURE) PIPE TO DRAIN (2)	1/4" NPT
12	SRV (CONNECTION FOR USER SUPPLIED T&P) (2)	3/4" NPT
13	AIR VENT (2)	3/4" NPT
14	VACUUM BREAKER (2)	1/2" NPT
15	BLOWDOWN (3)	1/2" NPT
16	PRESSURE GAUGE (5)	1/4" NPT
17	BALANCING VALVE (2)	1" NPT

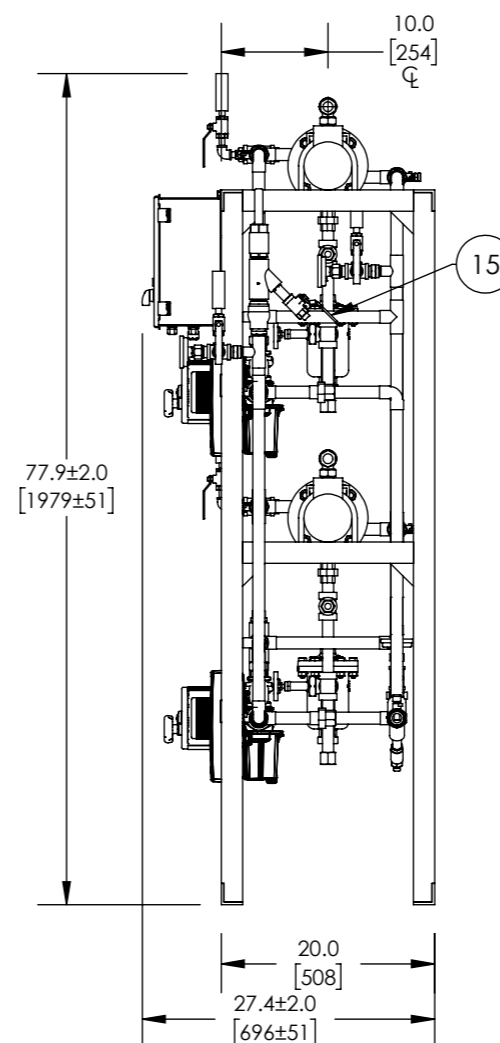

ITEM	MATERIAL
PIPING	COPPER TYPE "L"
EXCHANGER SHELL MATL.	CARBON STEEL
EXCHANGER TUBE MATL.	COPPER

NOTE(S):

- ALL DIMENSIONS +/-0.5 [13] UNLESS OTHERWISE SHOWN.
- COMPLETE ASSEMBLY LEAD FREE COMPLIANT - THE WETTED SURFACE OF THIS PRODUCT CONTACTED BY CONSUMABLE WATER CONTAINS LESS THAN ONE QUARTER OF ONE PERCENT (0.25%) OF LEAD BY WEIGHT.
- PACKAGE INCLUDES ALL REQUIRED INLET CHECK VALVES AND STRAINERS ON DOMESTIC SIDE.
- DRV, SAFETY SHUT OFF AND ELECTRICAL PANEL ARE PREWIRED TO PROVIDE A SINGLE ELECTRICAL LANDING POINT AT THE PANEL.

DO NOT SCALE DRAWING TOLERANCES UNLESS OTHERWISE SPECIFIED	
DIMENSIONING ENGLISH [mm]	
FRACTIONAL	± 1/64
ANGULAR:	± 2
DECIMAL	.XXXX ± .0005
	.XXX ± .005 .010
	.XX ± .015 .10
	.X ± .3

		NAME	DATE
		CFG	5/18/2015
DRAWN	RELEASED		

ARMSTRONG INTERNATIONAL Copyright © 2010 ARMSTRONG INTERNATIONAL, INC. DF415DWP40-40BS	
MATERIAL	SHEET 1 OF 1
REV	SALES