

APPROVAL
 BY: _____ DATE: _____
 APPROVED, PROCEED WITH FABRICATION
 APPROVED AS NOTED, PROCEED WITH FABRICATION IN ACCORDANCE WITH COMMENTS
 DISAPPROVED, DO NOT FABRICATE

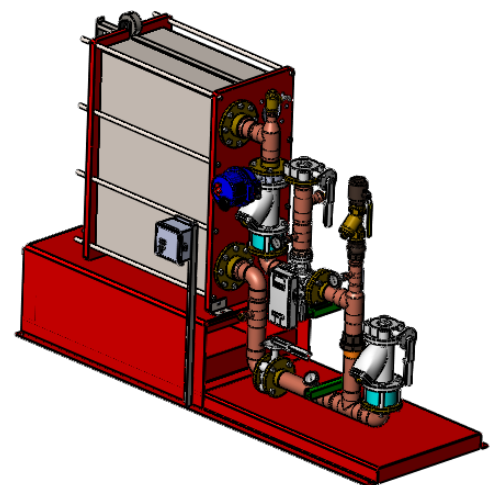

DIGITAL FLO BOILER WATER/WATER PLATE & FRAME HEAT EXCHANGER DOUBLE WALL

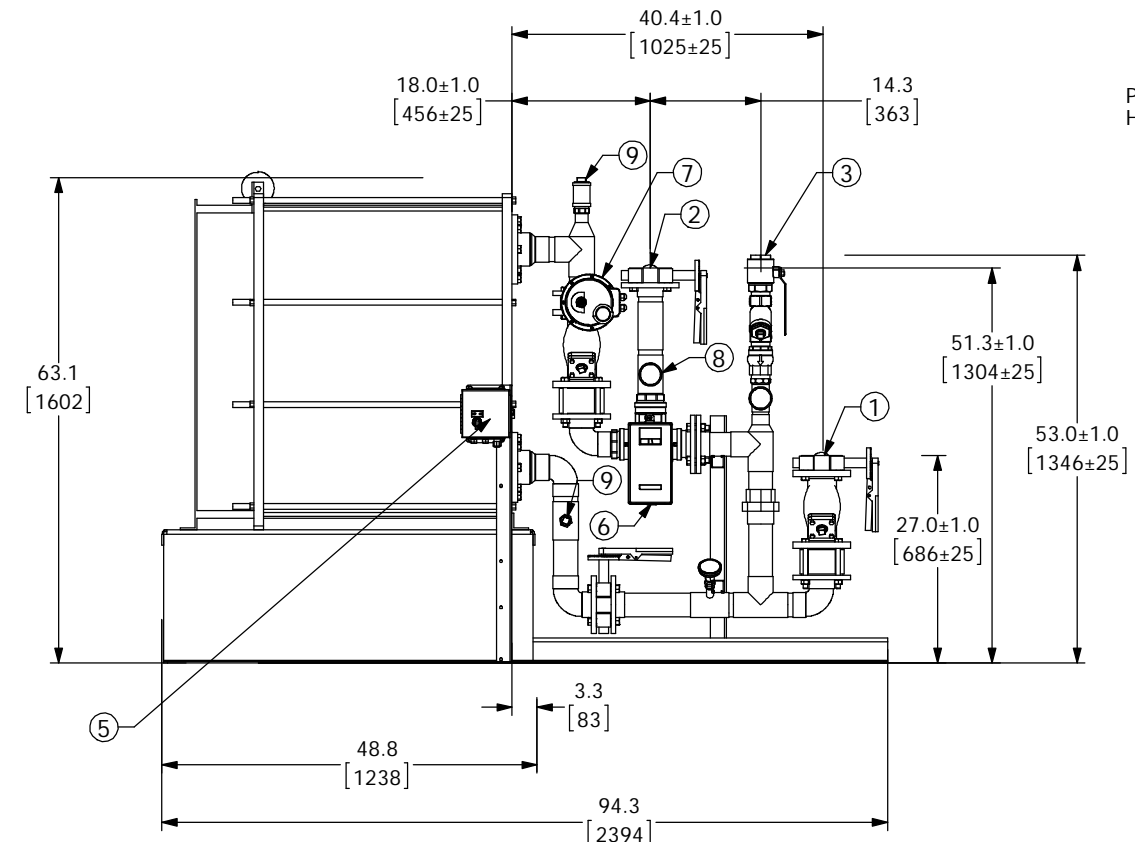

PIPING AND COMPONENTS HIDDEN TO SHOW CONNECTIONS

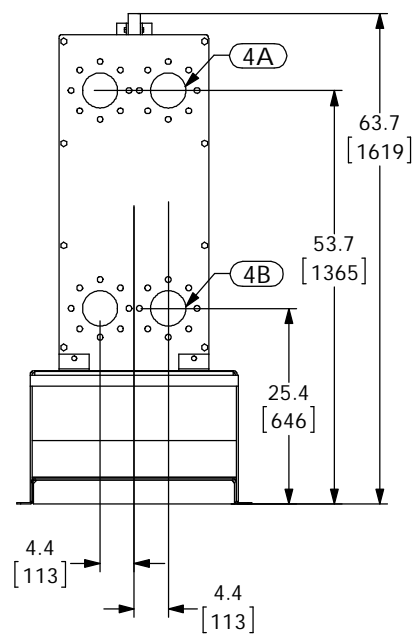

PROJECT NAME :

TAG :

ITEM	DESCRIPTION	CONNECTION
1	COLD WATER INLET	3" FLG ANSI 150
2	MIXED WATER OUTLET	3" FLG ANSI 150
3	RECIRC WATER INLET	2" NPT
4A	PRIMARY(BOILER) INLET	4" FLG ANSI 150
4B	PRIMARY(BOILER) OUTLET	4" FLG ANSI 150
5	ELECTRICAL PANEL	110VAC @ 0.7A
6	DRV80	3" NPT
7	N.C. ACTUATED BALL VALVE SAFETY SHUT OFF	3" WAFER
8	THERMOMETER (3)	
9	CIP CONNECTION (2)	1-1/2" AND 1" NPT
10	SRV(PRESSURE) PIPE TO DRAIN	1" NPT
11	SRV(CONNECTION FOR USER SUPPLIED T&P)	1-1/2" NPT

ITEM	MATERIAL
PIPING	COPPER TYPE "L"
EXCHANGER PLATE MATL.	T316L SS
EXCHANGER GASKET MATL.	NITRILE

- NOTE(S):
- ALL DIMENSIONS +/- .5[13] UNLESS OTHERWISE SHOWN.
 - COMPLETE ASSEMBLY LEAD FREE COMPLIANT - THE WETTED SURFACE OF THIS PRODUCT CONTACTED BY CONSUMABLE WATER CONTAINS LESS THAN ONE QUARTER OF ONE PERCENT (0.25%) OF LEAD BY WEIGHT.
 - PACKAGE INCLUDES ALL REQUIRED INLET CHECK VALVES AND STRAINERS ON DOMESTIC SIDE.
 - DRV, SAFETY SHUT OFF AND ELECTRICAL PANEL ARE PREWIRED TO PROVIDE A SINGLE ELECTRICAL LANDING POINT AT THE PANEL.

DO NOT SCALE DRAWING
 TOLERANCES UNLESS OTHERWISE SPECIFIED
 DIMENSIONING ENGLISH [mm]
 FRACTIONAL ± 1/64
 ANGULAR: ± 2

Armstrong

NAME	DATE
DRAWN: CFG	02/26/2013
RELEASED: SALES	

ARMSTRONG INTERNATIONAL
 Copyright © 2010 ARMSTRONG INTERNATIONAL, INC.
DF120WEDW80 3 FLG 3 FLG 2 NPT CPR

CONFIG# (C-XXXXXX)

MATERIAL

SHEET 1 OF 1
 DWG: D5XXXXX