

APPROVAL

BY: _____ DATE: _____

APPROVED, PROCEED WITH FABRICATION

APPROVED AS NOTED, PROCEED WITH FABRICATION IN ACCORDANCE WITH COMMENTS

DISAPPROVED, DO NOT FABRICATE

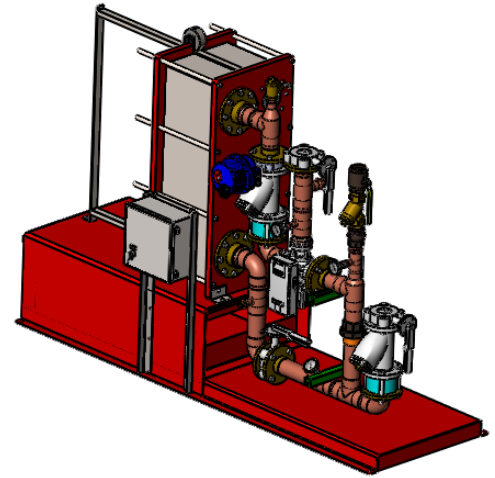

DIGITAL FLO BOILER WATER/WATER PLATE & FRAME HEAT EXCHANGER DOUBLE WALL

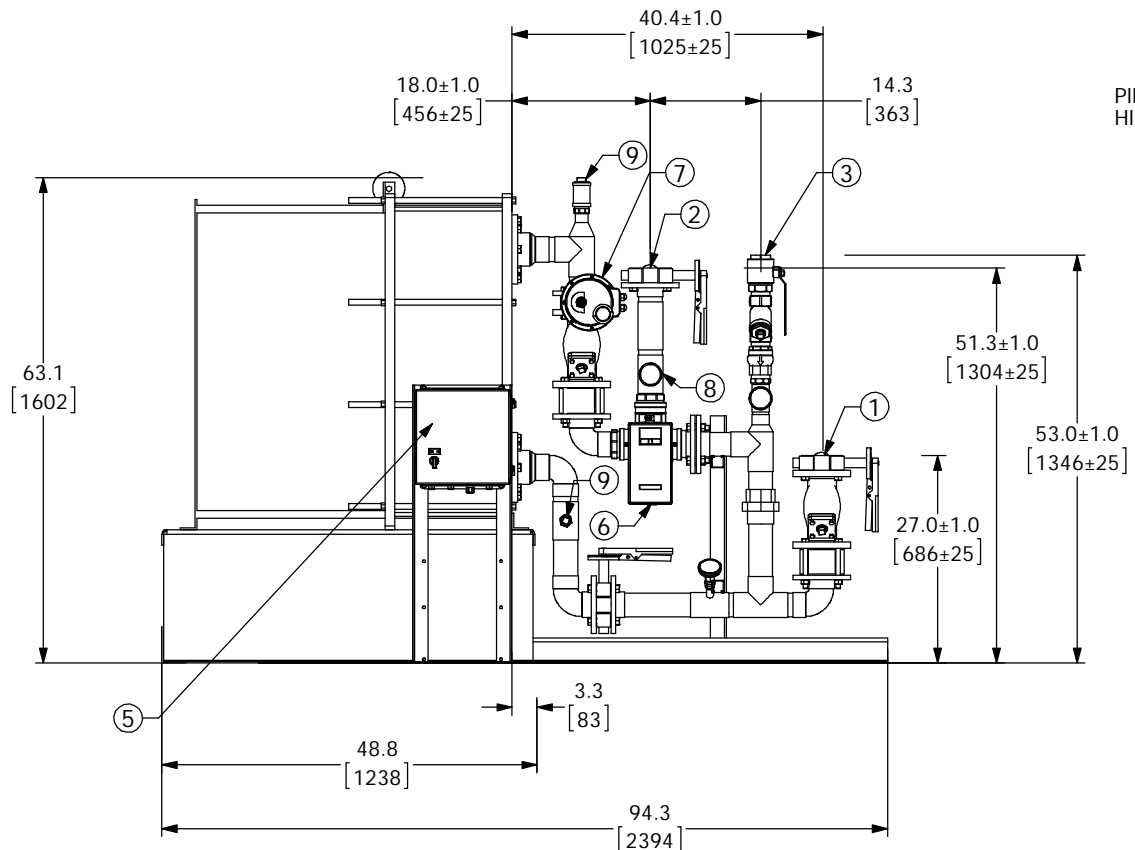

PIPING AND COMPONENTS HIDDEN TO SHOW CONNECTIONS

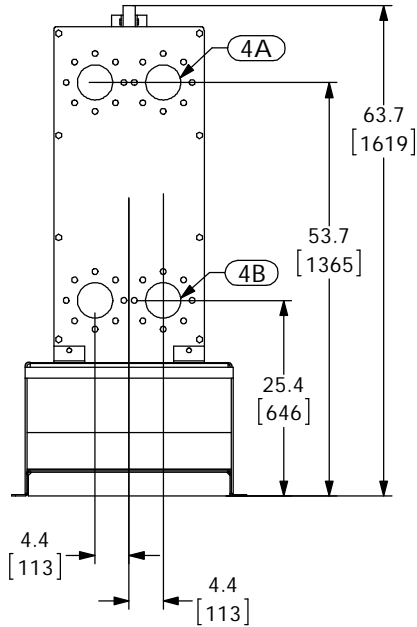

PROJECT NAME :

TAG :

ITEM	DESCRIPTION	CONNECTION
1	COLD WATER INLET	3" FLG ANSI 150
2	MIXED WATER OUTLET	3" FLG ANSI 150
3	RECIRC WATER INLET	2" NPT
4A	PRIMARY(BOILER) INLET	4" FLG ANSI 150
4B	PRIMARY(BOILER) OUTLET	4" FLG ANSI 150
5	ELECTRICAL PANEL/BRAINSCAN	110VAC @ 1.2A
6	DRV80	3" NPT
7	N.C. ACTUATED BALL VALVE SAFETY SHUT OFF	3" WAFER
8	THERMOMETER (3)	
9	CIP CONNECTION (2)	1-1/2" AND 1" NPT
10	SRV(PRESSURE) PIPE TO DRAIN	1" NPT
11	SRV(CONNECTION FOR USER SUPPLIED T&P)	1-1/2" NPT

ITEM	MATERIAL
PIPING	COPPER TYPE "L"
EXCHANGER PLATE MATL.	T316L SS
EXCHANGER GASKET MATL.	NITRILE

- NOTE(S):
- ALL DIMENSIONS +/- .5[13] UNLESS OTHERWISE SHOWN.
 - COMPLETE ASSEMBLY LEAD FREE COMPLIANT - THE WETTED SURFACE OF THIS PRODUCT CONTACTED BY CONSUMABLE WATER CONTAINS LESS THAN ONE QUARTER OF ONE PERCENT (0.25%) OF LEAD BY WEIGHT.
 - PACKAGE INCLUDES ALL REQUIRED INLET CHECK VALVES AND STRAINERS ON DOMESTIC SIDE.
 - DRV, SAFETY SHUT OFF AND ELECTRICAL PANEL ARE PREWIRED TO PROVIDE A SINGLE ELECTRICAL LANDING POINT AT THE PANEL.

 Armstrong																						
DO NOT SCALE DRAWING TOLERANCES UNLESS OTHERWISE SPECIFIED DIMENSIONING ENGLISH [mm]																						
FRACTIONAL ± 1/64 ANGULAR: ± 2																						
<table border="1"> <tr> <th></th> <th>IN.</th> <th>MM</th> </tr> <tr> <td>DECIMAL</td> <td>XXX ± .0005</td> <td>----</td> </tr> <tr> <td></td> <td>XXX ± .005</td> <td>.010</td> </tr> <tr> <td></td> <td>XX ± .015</td> <td>.10</td> </tr> <tr> <td></td> <td>X</td> <td>.3</td> </tr> </table>		IN.	MM	DECIMAL	XXX ± .0005	----		XXX ± .005	.010		XX ± .015	.10		X	.3	<table border="1"> <tr> <th>NAME</th> <th>DATE</th> </tr> <tr> <td>DRAWN</td> <td>CFG 02/26/2013</td> </tr> <tr> <td>RELEASED</td> <td>SALES</td> </tr> </table>	NAME	DATE	DRAWN	CFG 02/26/2013	RELEASED	SALES
	IN.	MM																				
DECIMAL	XXX ± .0005	----																				
	XXX ± .005	.010																				
	XX ± .015	.10																				
	X	.3																				
NAME	DATE																					
DRAWN	CFG 02/26/2013																					
RELEASED	SALES																					

ARMSTRONG INTERNATIONAL
Copyright © 2010 ARMSTRONG INTERNATIONAL, INC.

DF120WDW80BS 3 FLG 3 FLG 2 NPT CPR

CONFIG# (C-XXXXXX)

MATERIAL	SHEET 1 OF 1
REV	DWG: D5XXXXX