

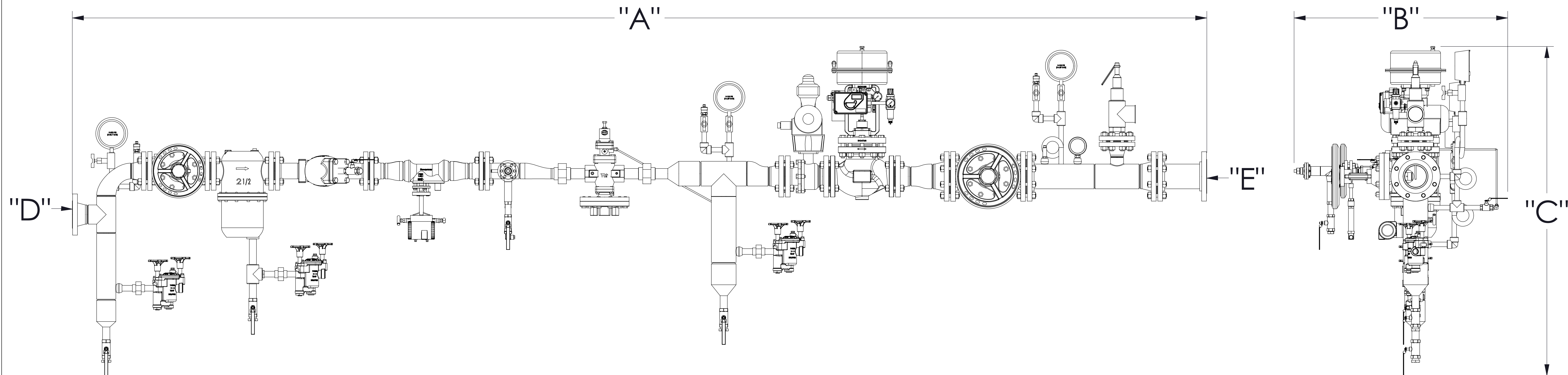

STANDARD ASH MODELS FOR NORTH AMERICA

	ASH5 TPH 85-100 PSI [5.9-6.9 BARG]	ASH5 TPH 115-145 PSI [7.9-10 BARG]	ASH10 TPH 85-100 PSI 5.9-6.9 BARG]	ASH10 TPH 115-145 PSI [7.9-10 BARG]	ASH15 TPH 85-115 PSI [5.9-7.9 BARG]	ASH15 TPH 130-145 PSI [9-10 BARG]
"A"	165	165	181	178	207	205
"B"	38	38	39	39	39	39
"C"	52	52	58	56	61	59
INLET-"D"	1-1/2	1-1/2	2-1/2	2	3	2-1/2
OUTLET-"E"	2	2	3	3	4	4
WEIGHT	1225	1240	2060	2010	2630	2730

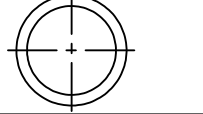



 DO NOT SCALE DRAWING
 TOLERANCES UNLESS OTHERWISE SPECIFIED
 DIMENSIONING ENGLISH [mm]
 FRACTIONAL ± 1/64
 ANGULAR: ± 2

DECIMAL	IN.	MM
.XXXX ±	.0005	-----
.XXX ±	.005	.010
.XX ±	.015	.10
.X	-----	.3

Armstrong[®]

	NAME	DATE
DRAWN		
RELEASED		

ARMSTRONG INTERNATIONAL
 Copyright © 2010 ARMSTRONG INTERNATIONAL, INC.
ASH STANDARD MODELS - ATR

MATERIAL	REV	DWG.	SHEET 1 OF 1