

**NOTES:**

- TANK MATERIAL: STAINLESS STEEL
- ALL DIMENSIONS ARE ±0.25"
- DRAWING NOT FOR CONSTRUCTION
- CONSULT FACTORY AT TIME OF ORDER FOR CURRENT PRINT
- INLET BASKET STRAINER OR Y-STRAINER ALSO AVAILABLE

**CONTROL PANEL OPTIONS ALSO AVAILABLE (NOT SHOWN):**

- NEMA 4 OR NEMA 4X OR NEMA 3R CONSTRUCTION
- ELECTRIC ALTERNATOR
- POWER ON LIGHT
- PUMP TEST BUTTON
- PUMP RUN TIME METER
- EXTRA DRY CONTACTS
- UL/CUL LABELED PANEL
- HIGH LEVEL ALARM HORN & LIGHT W/SILENCE SWITCH
- LEAD-AUTO-LAG SELECTOR SWITCH

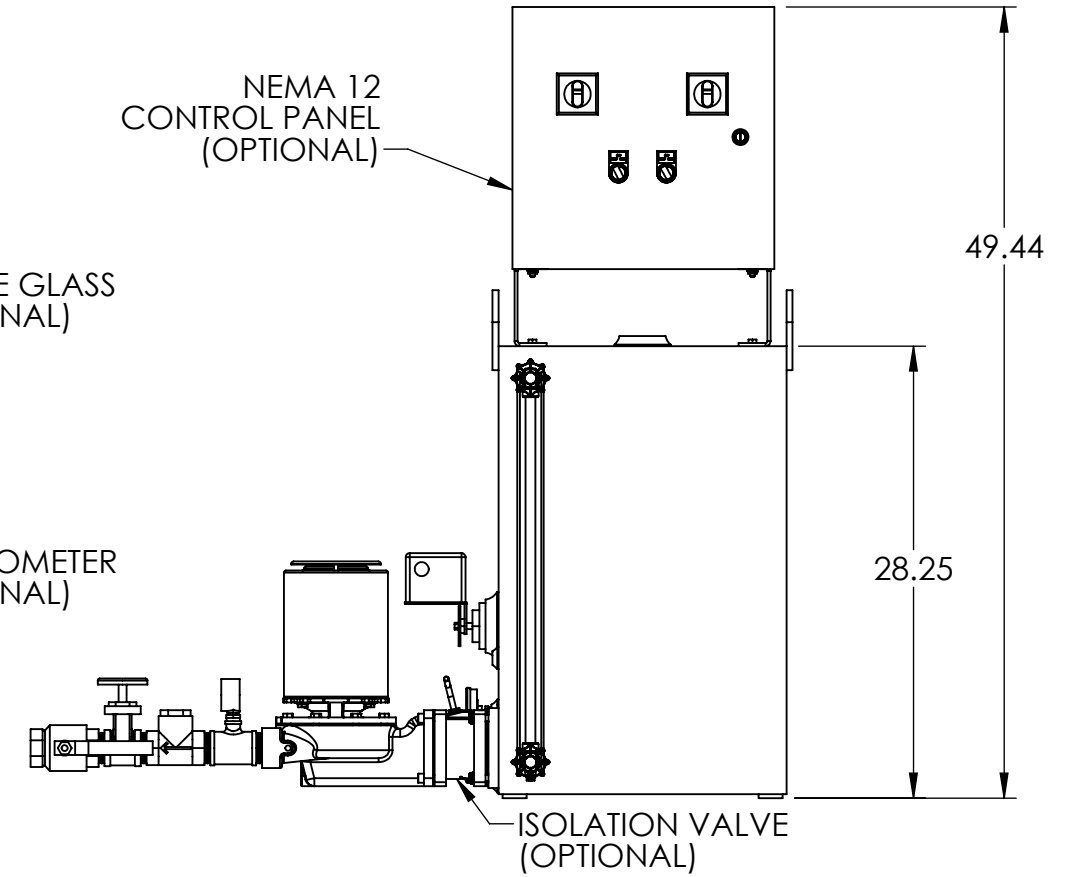
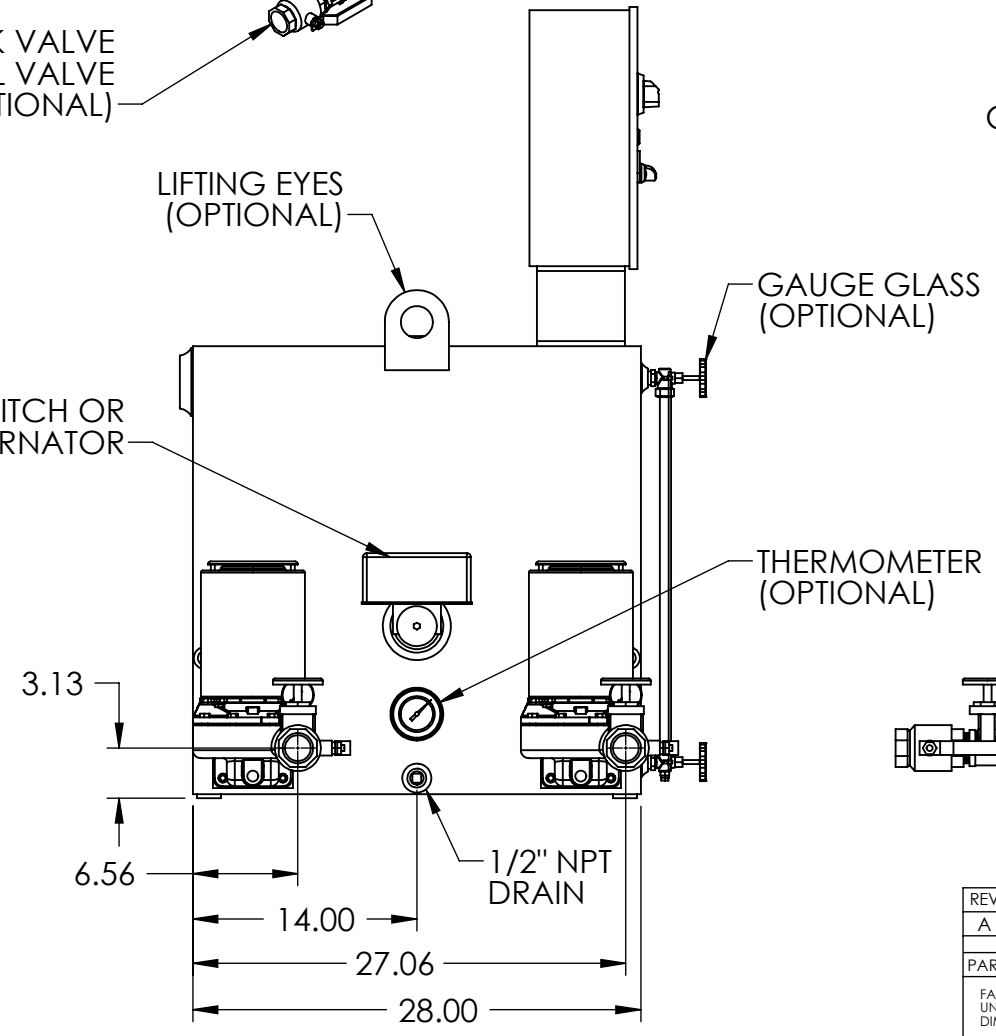
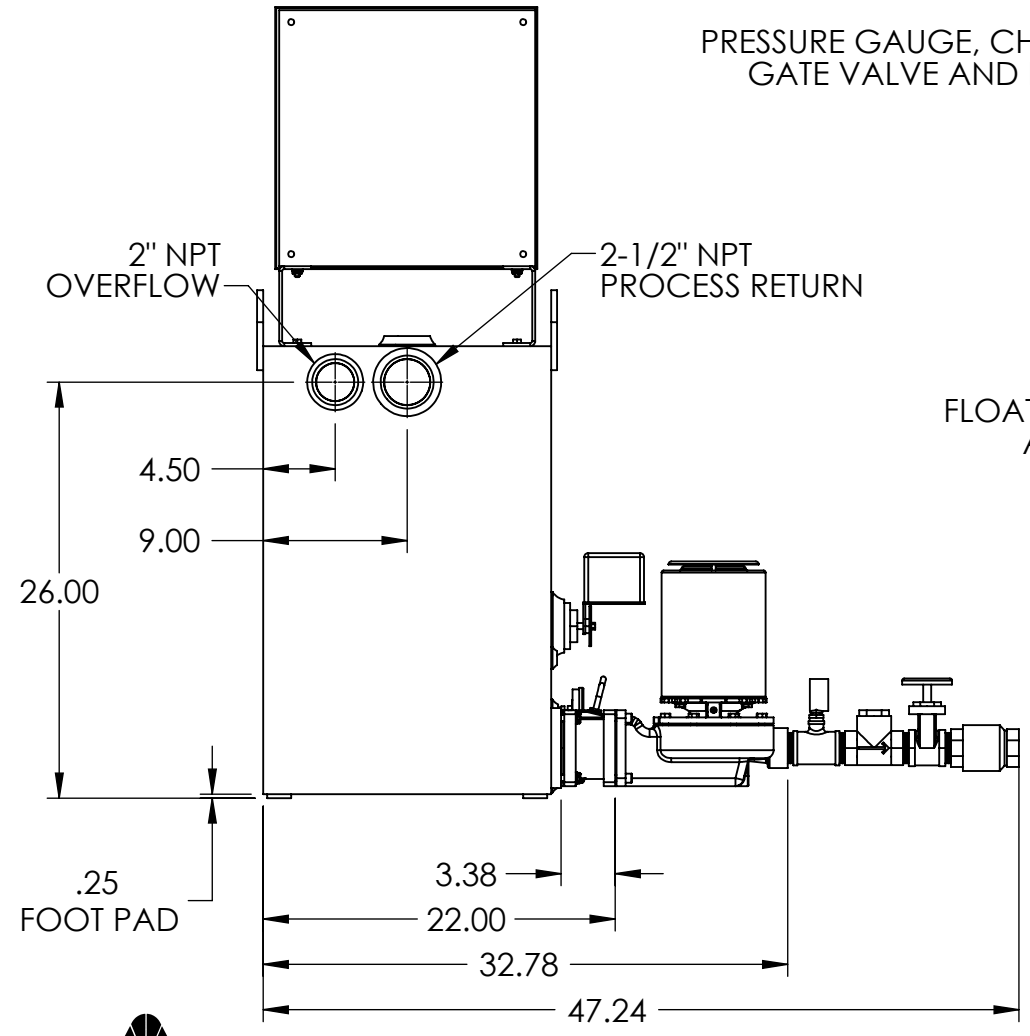
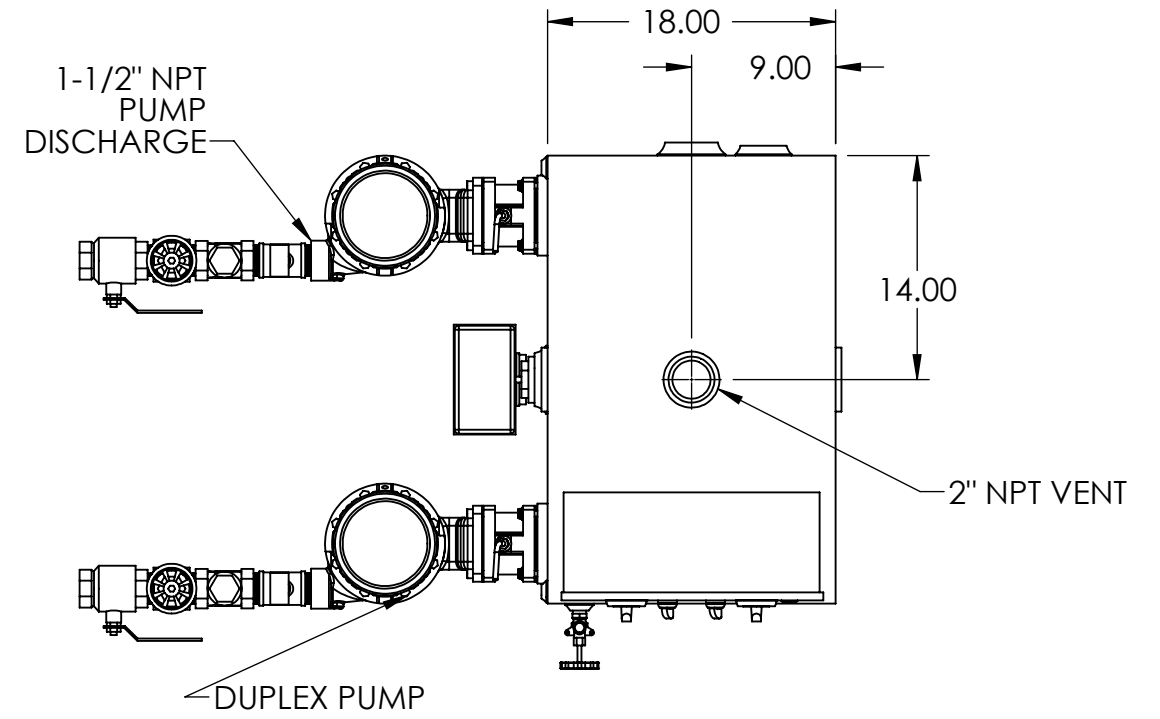
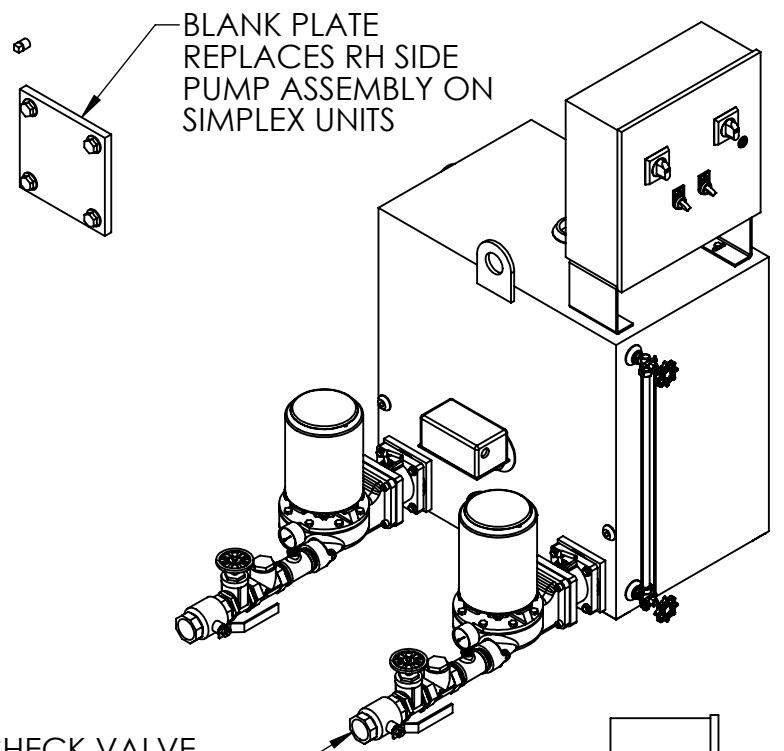

REV	DESCRIPTION	ECN	NAME	DATE
A	Initial Design		GJM	4/12/2018

PART NO:	Ref PartNo	NAME	DATE	 THIRD ANGLE PROJECTION TITLE <b>60 GALLON SIMPLEX/DUPLEX                  4300 SERIES                  "J" CONDENSATE PUMP</b>
FABRICATION TOLERANCES UNLESS OTHERWISE SPECIFIED: DIMENSIONS ARE IN INCHES	DRAWN	GJM	4/12/2018	
TOLERANCES: ANGULAR DIMENSIONS ±1° FRACTIONS ±1/32	CHECKED			
TWO PLACE DECIMAL ±0.06 THREE PLACE DECIMAL ±0.030	ENG APPR.			
		PRODUCT FAMILY HTSP Boiler and Condensate		
		PRODUCT CATEGORY		
SHEET: 1 OF 1	WEIGHT 365.30	DRAWING MAY NOT BE PRINTED TO SCALE. SCALE: 1:12		DWG NO. 684.43060.00J
				REV A