

**NOTES:**

- TANK MATERIAL: STAINLESS STEEL
- ALL DIMENSIONS ARE  $\pm 0.25"$
- DRAWING NOT FOR CONSTRUCTION
- CONSULT FACTORY AT TIME OF ORDER FOR CURRENT PRINT
- INLET BASKET STRAINER OR Y-STRAINER ALSO AVAILABLE

**CONTROL PANEL OPTIONS ALSO AVAILABLE (NOT SHOWN):**

- NEMA 4 OR NEMA 4X OR NEMA 3R CONSTRUCTION
- POWER ON LIGHT
- PUMP TEST BUTTON
- PUMP RUN TIME METER
- EXTRA DRY CONTACTS
- UL/CUL LABELED PANEL
- HIGH LEVEL ALARM HORN & LIGHT W/SILENCE SWITCH

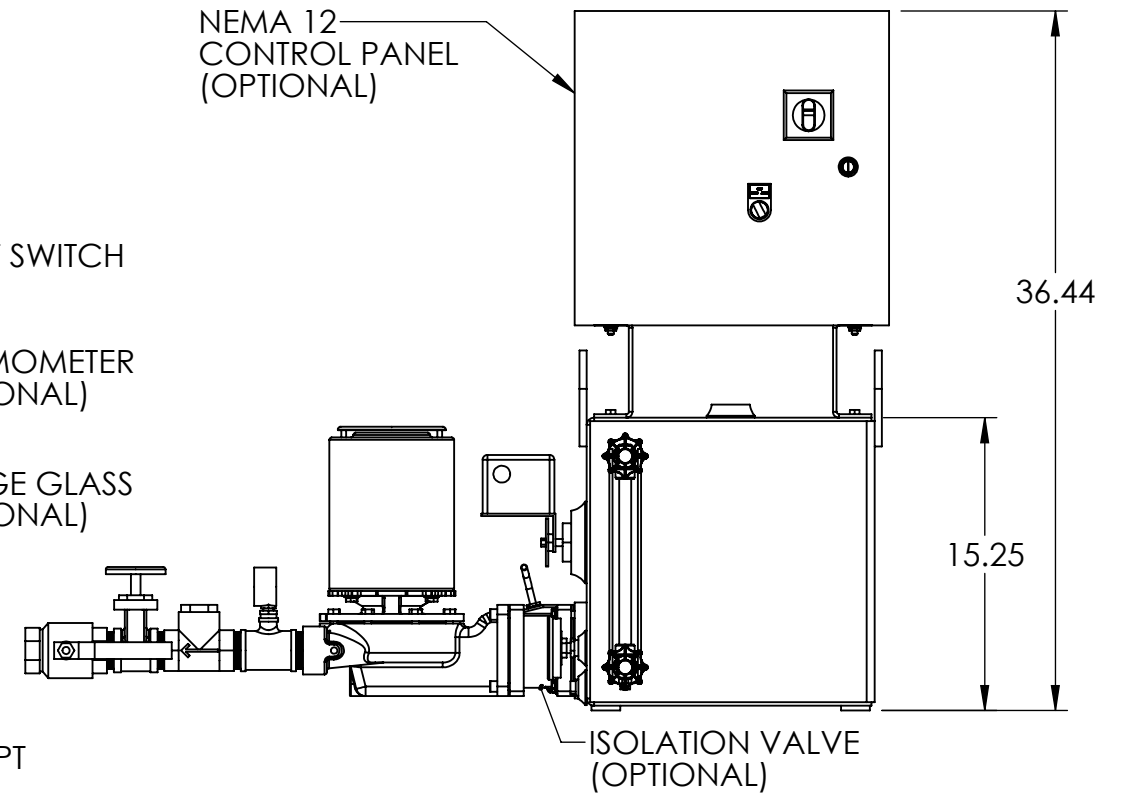
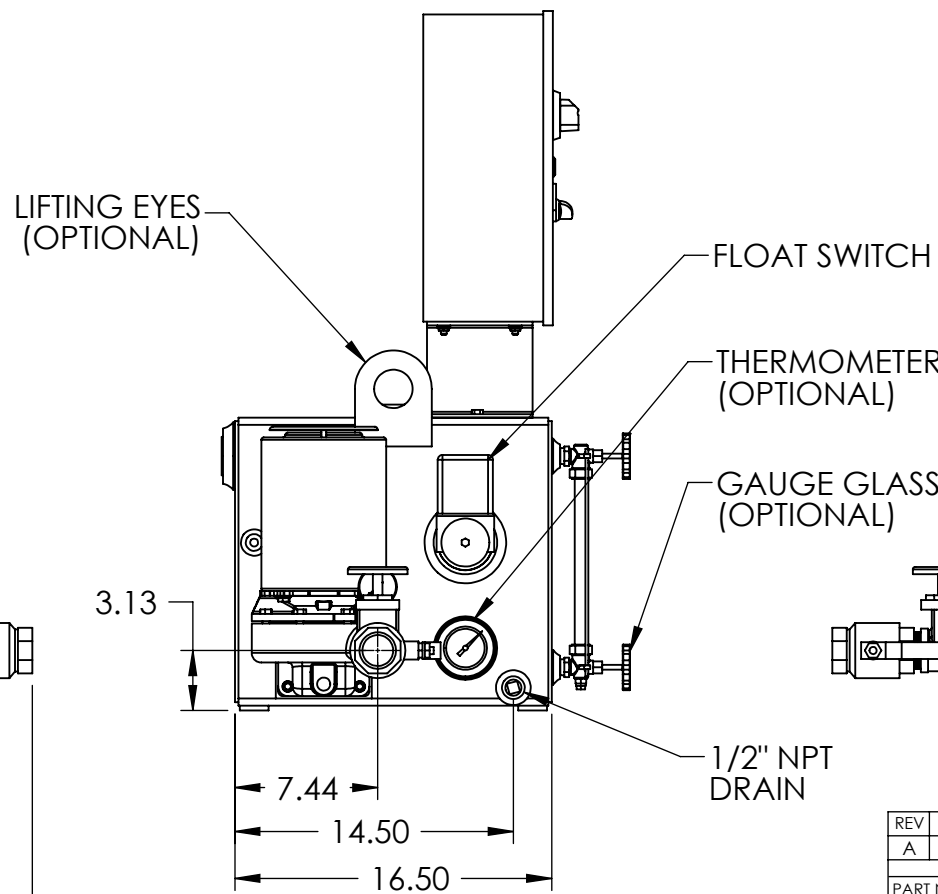
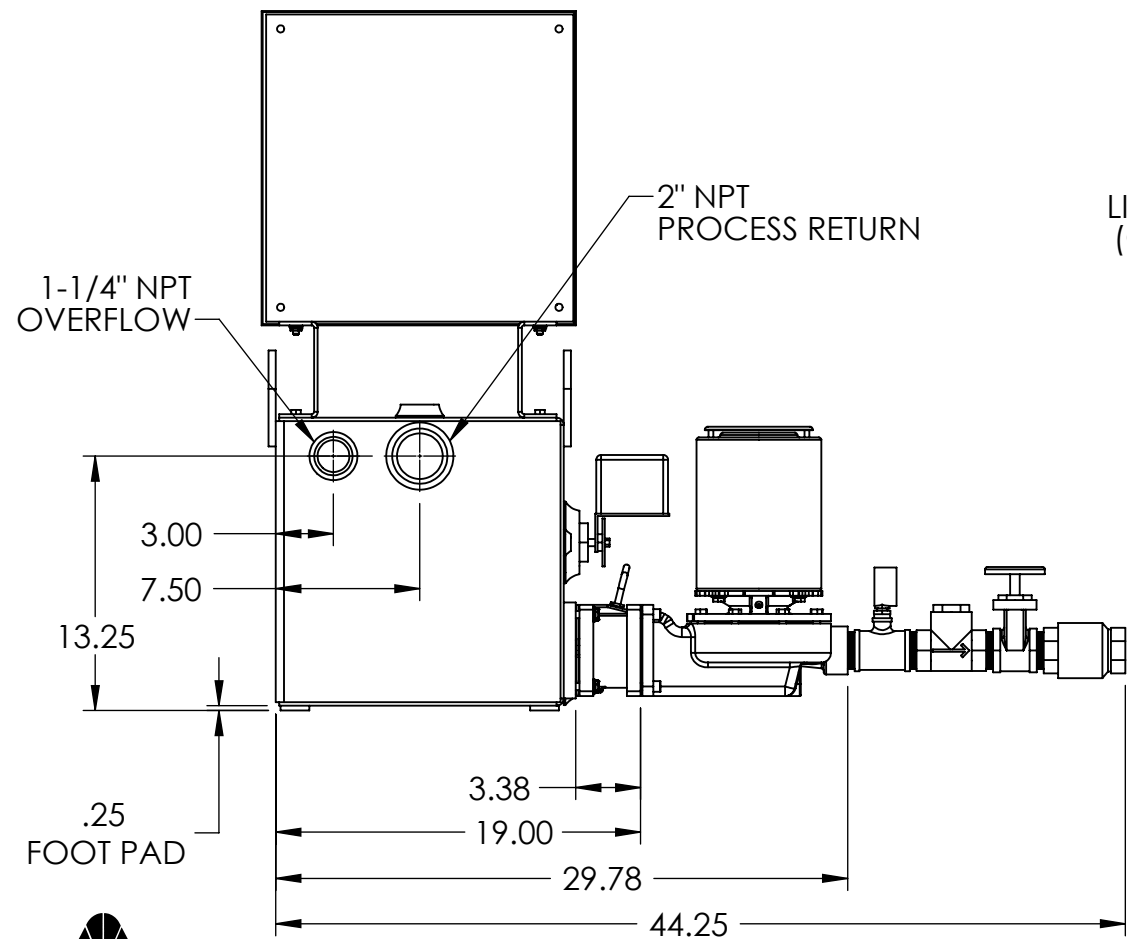
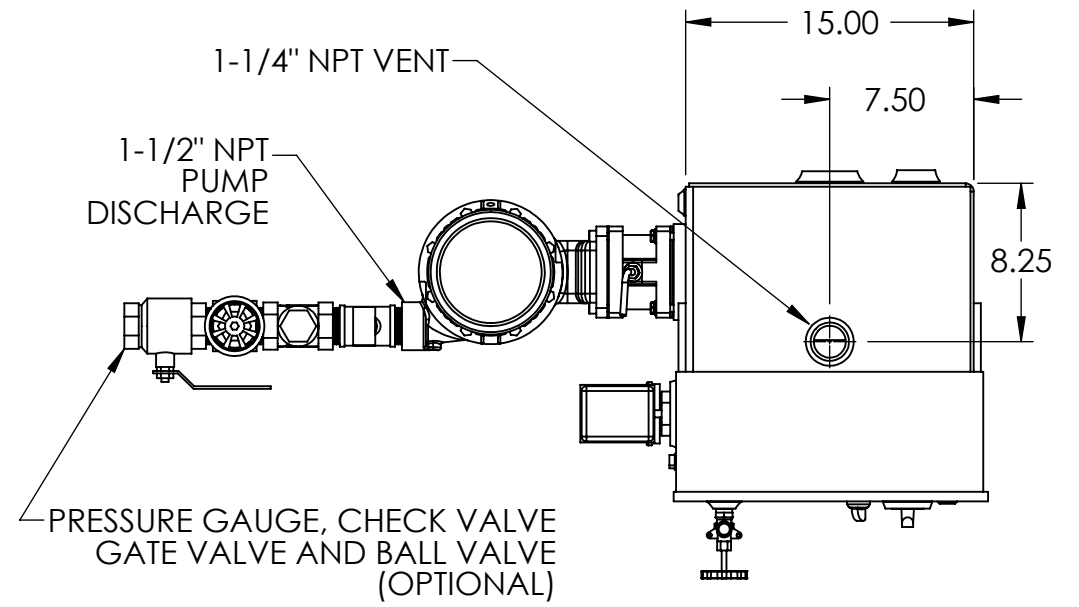
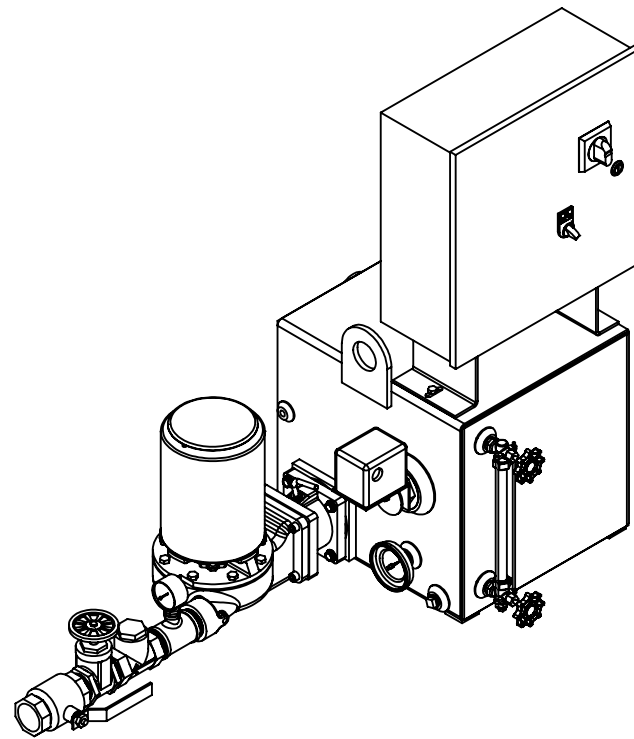

REV	DESCRIPTION	ECN	NAME	DATE
A	Initial Design		GJM	4/12/2018

PART NO:	Ref PartNo	NAME	DATE	TITLE
		GJM	4/12/2018	15 GALLON SS SIMPLEX 4300 SERIES "J" CONDENSATE PUMP
FABRICATION TOLERANCES UNLESS OTHERWISE SPECIFIED: DIMENSIONS ARE IN INCHES TOLERANCES: ANGULAR DIMENSIONS $\pm 1^\circ$ FRACTIONS $\pm 1/32$ TWO PLACE DECIMAL $\pm 0.06$ THREE PLACE DECIMAL $\pm 0.030$				THIRD ANGLE PROJECTION DWG NO. 684.43015.01J REV A
SHEET: 1 OF 1 WEIGHT 261.77		DRAWING MAY NOT BE PRINTED TO SCALE. SCALE: 1:10		

