

**NOTES:**

- TANK MATERIAL: STAINLESS STEEL
- ALL DIMENSIONS ARE  $\pm 0.25"$
- DRAWING NOT FOR CONSTRUCTION
- CONSULT FACTORY AT TIME OF ORDER FOR CURRENT PRINT
- INLET BASKET STRAINER OR Y-STRAINER ALSO AVAILABLE

**CONTROL PANEL OPTIONS ALSO AVAILABLE (NOT SHOWN):**

- NEMA 4 OR NEMA 4X OR NEMA 3R CONSTRUCTION
- ELECTRIC ALTERNATOR
- POWER ON LIGHT
- PUMP TEST BUTTON
- PUMP RUN TIME METER
- EXTRA DRY CONTACTS
- UL/CUL LABELED PANEL
- HIGH LEVEL ALARM HORN & LIGHT W/SILENCE SWITCH
- LEAD-AUTO-LAG SELECTOR SWITCH

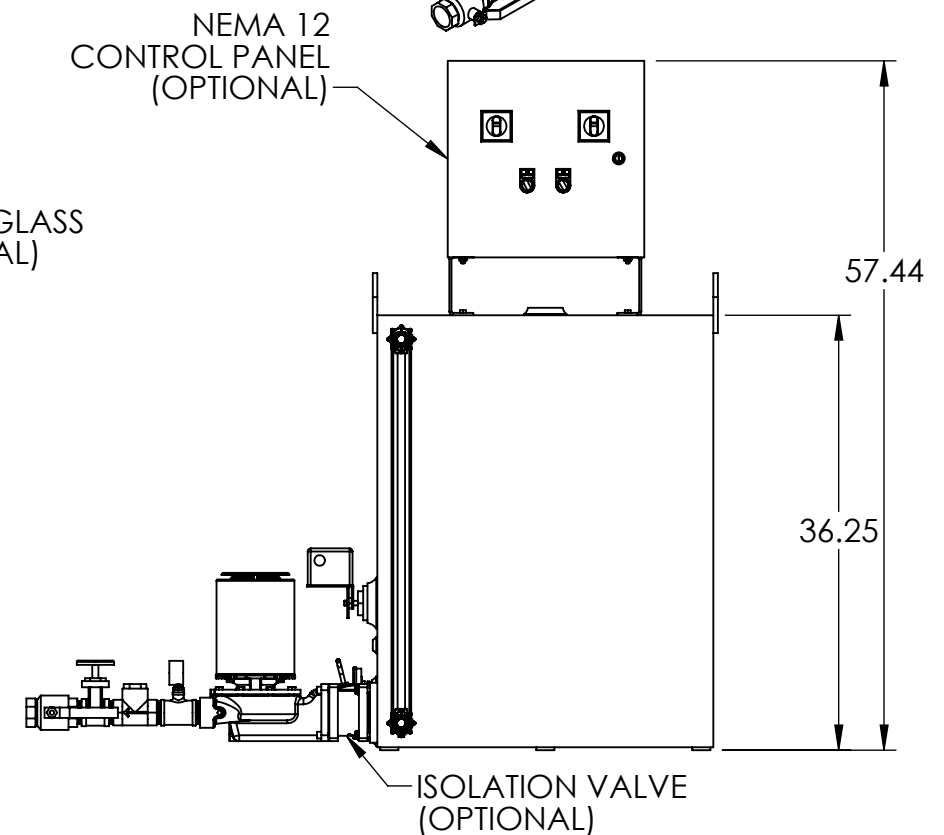
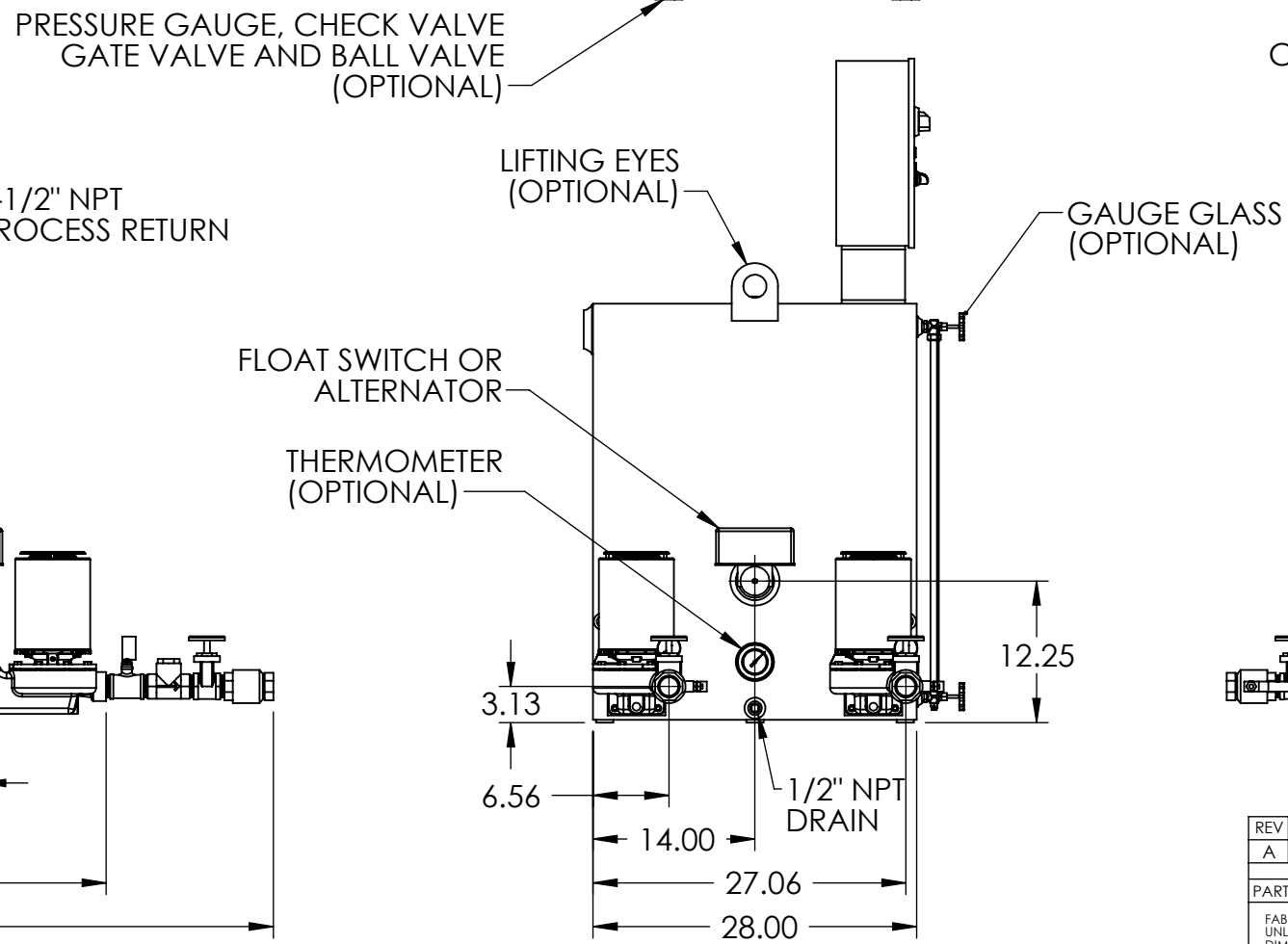
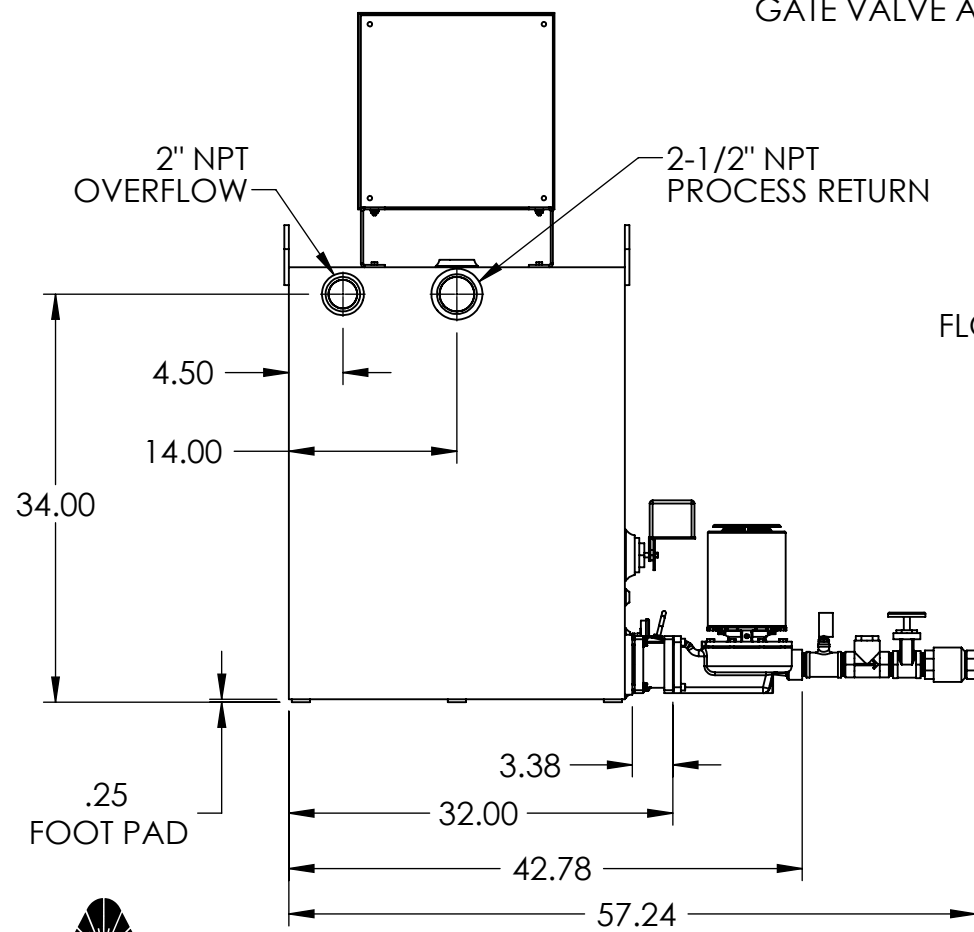
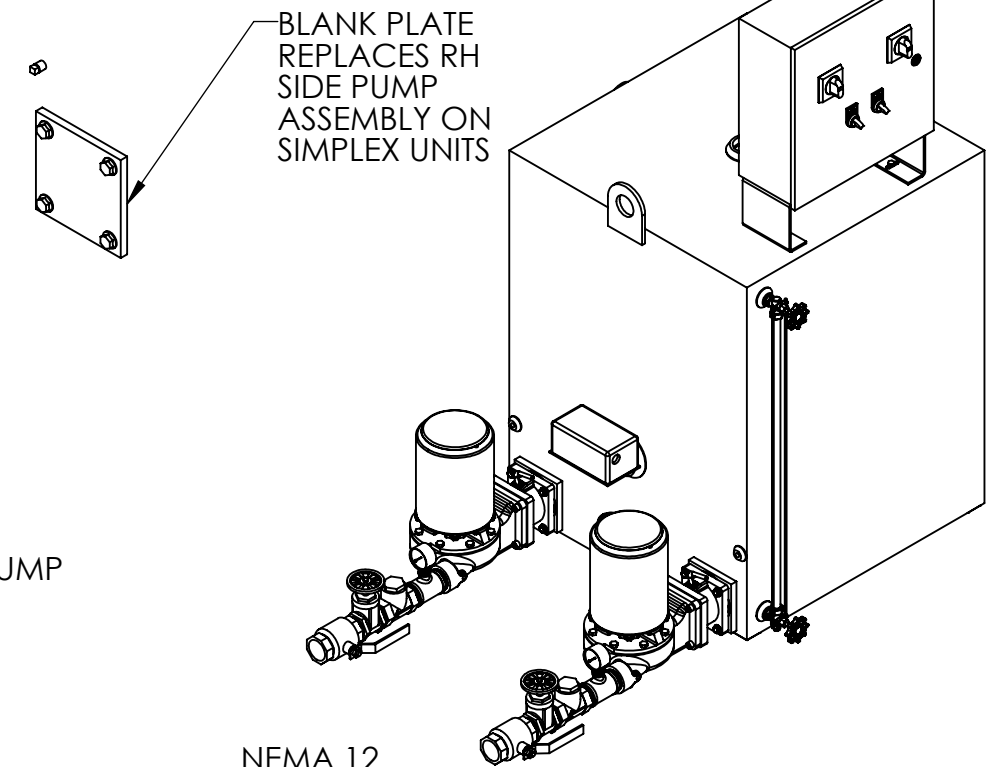
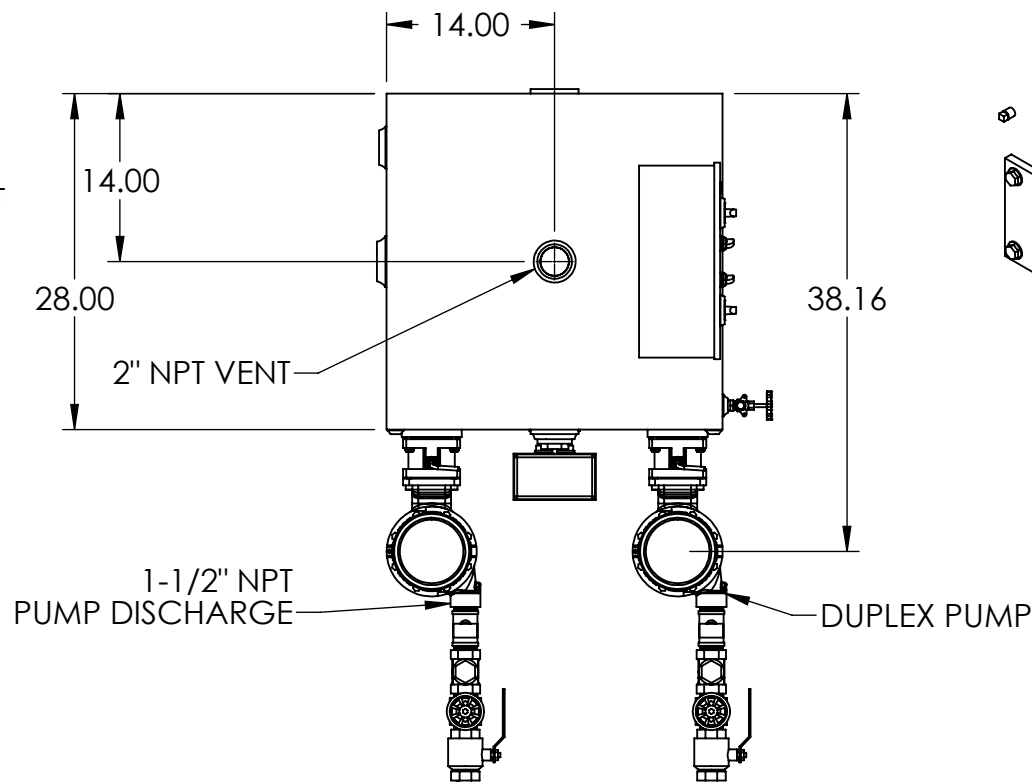

| REV                              | DESCRIPTION    | ECN                       | NAME                                 | DATE          |
|----------------------------------|----------------|---------------------------|--------------------------------------|---------------|
| A                                | Initial Design |                           | GJM                                  | 2/18/2016     |
| PART NO: Ref PartNo              |                | NAME                      | DATE                                 |               |
| DRAWN                            |                | GJM                       | 4/12/2018                            |               |
| CHECKED                          |                |                           |                                      |               |
| ENG APPR.                        |                |                           |                                      |               |
| TOLERANCES:                      |                | THIRD ANGLE PROJECTION    |                                      |               |
| ANGULAR DIMENSIONS $\pm 1^\circ$ |                | TITLE                     |                                      |               |
| FRACTIONS $\pm 1/32$             |                | 120 GALLON SIMPLEX/DUPLEX |                                      |               |
| TWO PLACE DECIMAL $\pm 0.06$     |                | 4300 SERIES               |                                      |               |
| THREE PLACE DECIMAL $\pm 0.030$  |                | "J" CONDENSATE PUMP       |                                      |               |
| SHEET: 1 OF 1                    |                | WEIGHT                    | DRAWING MAY NOT BE PRINTED TO SCALE. | DWG NO.       |
|                                  |                | 632.74                    | SCALE: 1:16                          | 684.43120.00J |
|                                  |                |                           |                                      | REV           |
|                                  |                |                           |                                      | A             |