

**NOTES:**

- TANK MATERIAL: STAINLESS STEEL
- ALL DIMENSIONS ARE ±0.25"
- DRAWING NOT FOR CONSTRUCTION
- CONSULT FACTORY AT TIME OF ORDER FOR CURRENT PRINT
- INLET BASKET STRAINER OR Y-STRAINER ALSO AVAILABLE

**CONTROL PANEL OPTIONS ALSO AVAILABLE (NOT SHOWN):**

- NEMA 4 OR NEMA 4X OR NEMA 3R CONSTRUCTION
- POWER ON LIGHT
- PUMP TEST BUTTON
- PUMP RUN TIME METER
- EXTRA DRY CONTACTS
- UL/CUL LABELED PANEL
- HIGH LEVEL ALARM HORN & LIGHT W/SILENCE SWITCH

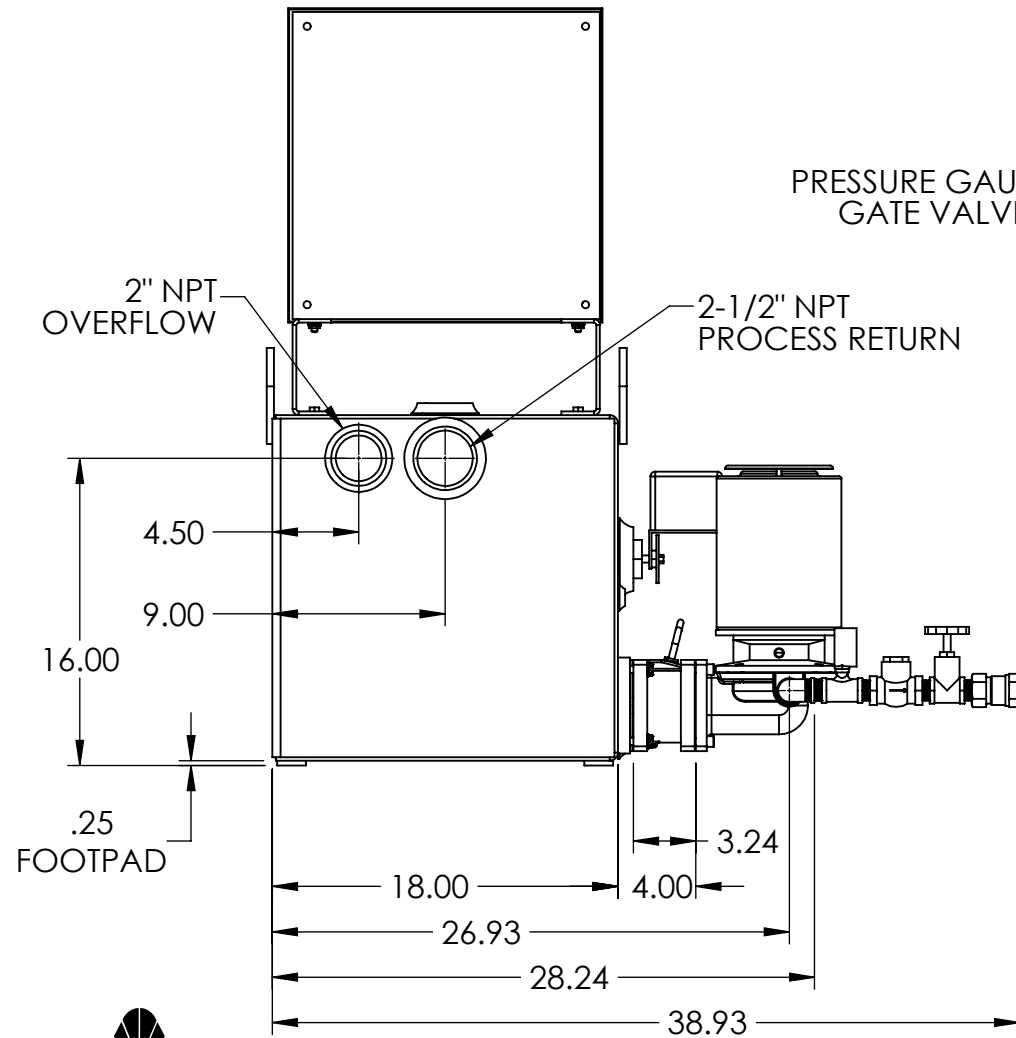
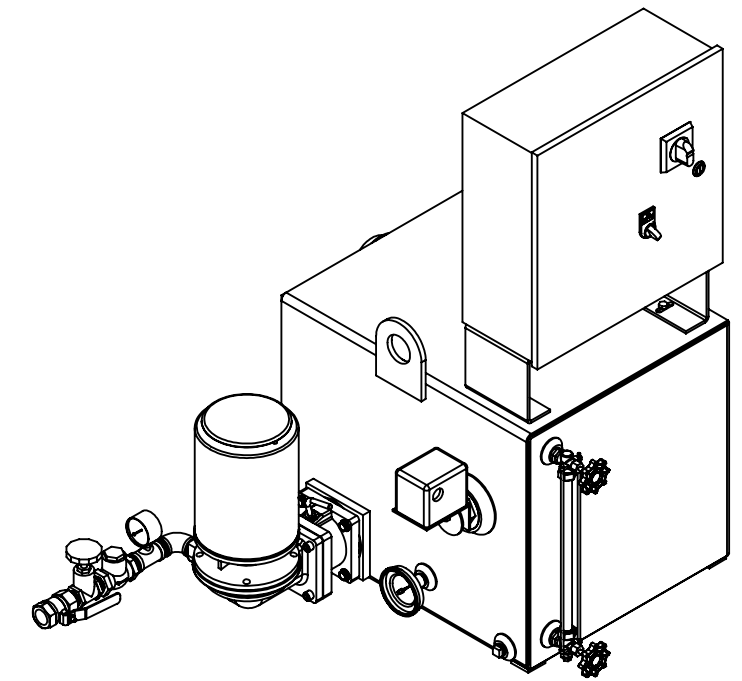
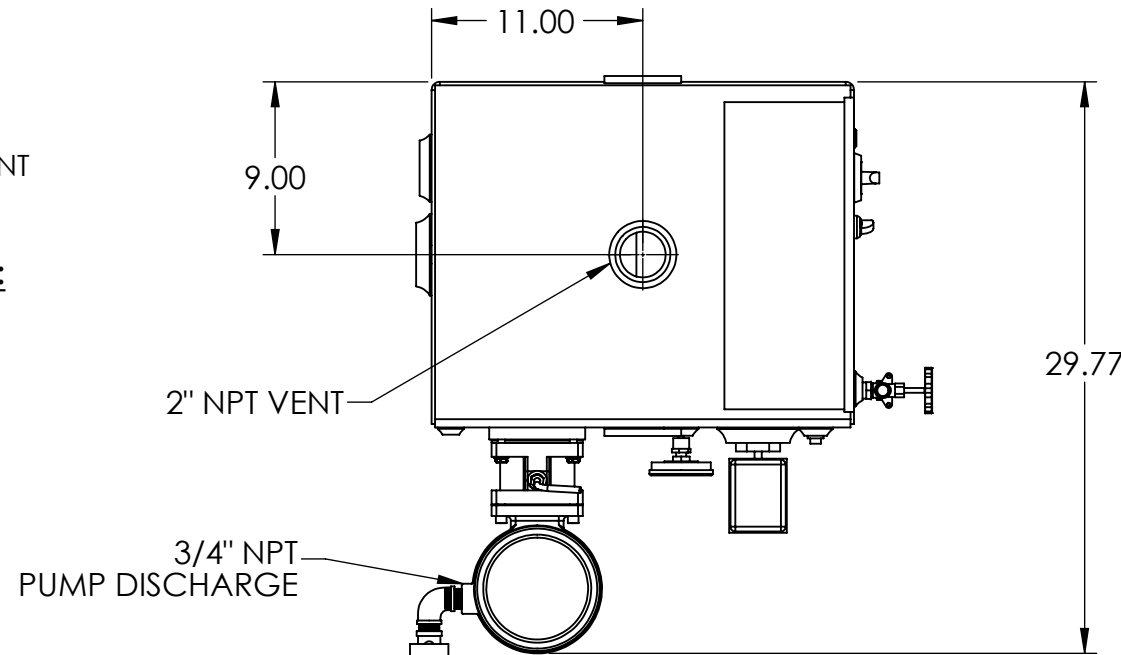

PRESSURE GAUGE, CHECK VALVE  
GATE VALVE AND BALL VALVE  
(OPTIONAL)

LIFTING EYES  
(OPTIONAL)

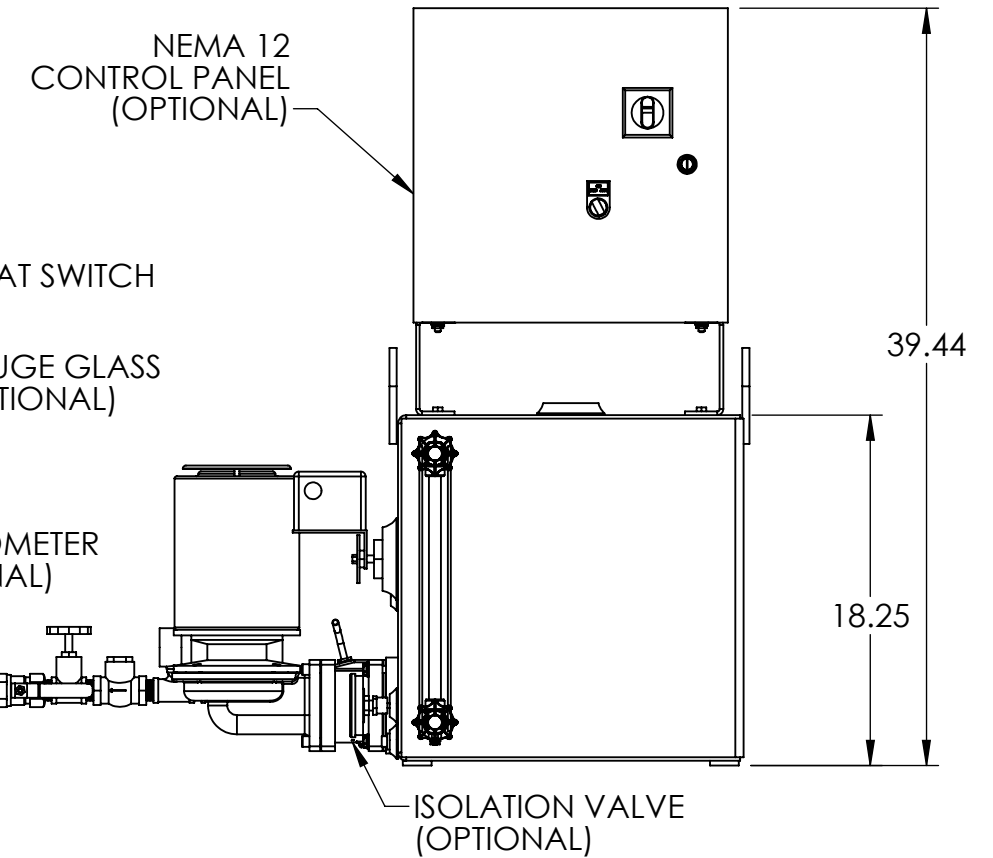
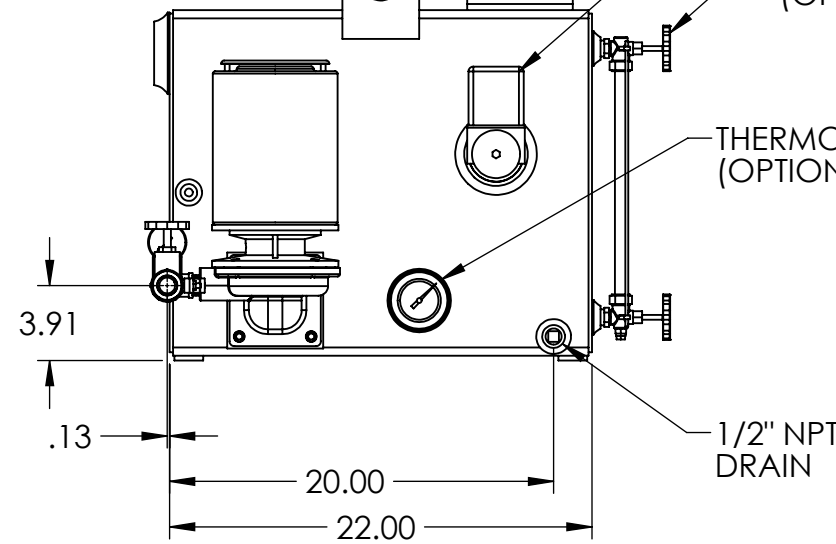

REV	DESCRIPTION	ECN	NAME	DATE
A	INITIAL DESIGN		GJM	3/16/2018

PART NO:	Ref PartNo	NAME	DATE
		GJM	3/16/2018

DESCRIPTION	DATE	NAME
DRAWN		GJM
CHECKED		
ENG APPR.		

TOLERANCES:
FABRICATION TOLERANCES UNLESS OTHERWISE SPECIFIED: DIMENSIONS ARE IN INCHES
ANGULAR DIMENSIONS ±1°
FRACTIONS ±1/32
TWO PLACE DECIMAL ±0.06
THREE PLACE DECIMAL ±0.030

PRODUCT FAMILY	PRODUCT CATEGORY
HTSP Boiler and Condensate	

TITLE	THIRD ANGLE PROJECTION
30 GALLON SS SIMPLEX 4300 SERIES "G" CONDENSATE PUMP	

SHEET: 1 OF 1	WEIGHT	DRAWING MAY NOT BE PRINTED TO SCALE.	DWG NO.	REV
		SCALE: 1:10	684.43030.01G	A

