

NOTES:

- TANK MATERIAL: STAINLESS STEEL
- ALL DIMENSIONS ARE $\pm 0.25"$
- DRAWING NOT FOR CONSTRUCTION
- CONSULT FACTORY AT TIME OF ORDER FOR CURRENT PRINT
- INLET BASKET STRAINER OR Y-STRAINER ALSO AVAILABLE

CONTROL PANEL OPTIONS ALSO AVAILABLE (NOT SHOWN):

- NEMA 4 OR NEMA 4X OR NEMA 3R CONSTRUCTION
- ELECTRIC ALTERNATOR
- POWER ON LIGHT
- PUMP TEST BUTTON
- PUMP RUN TIME METER
- EXTRA DRY CONTACTS
- UL/CUL LABELED PANEL
- HIGH LEVEL ALARM HORN & LIGHT W/SILENCE SWITCH
- LEAD-AUTO-LAG SELECTOR SWITCH

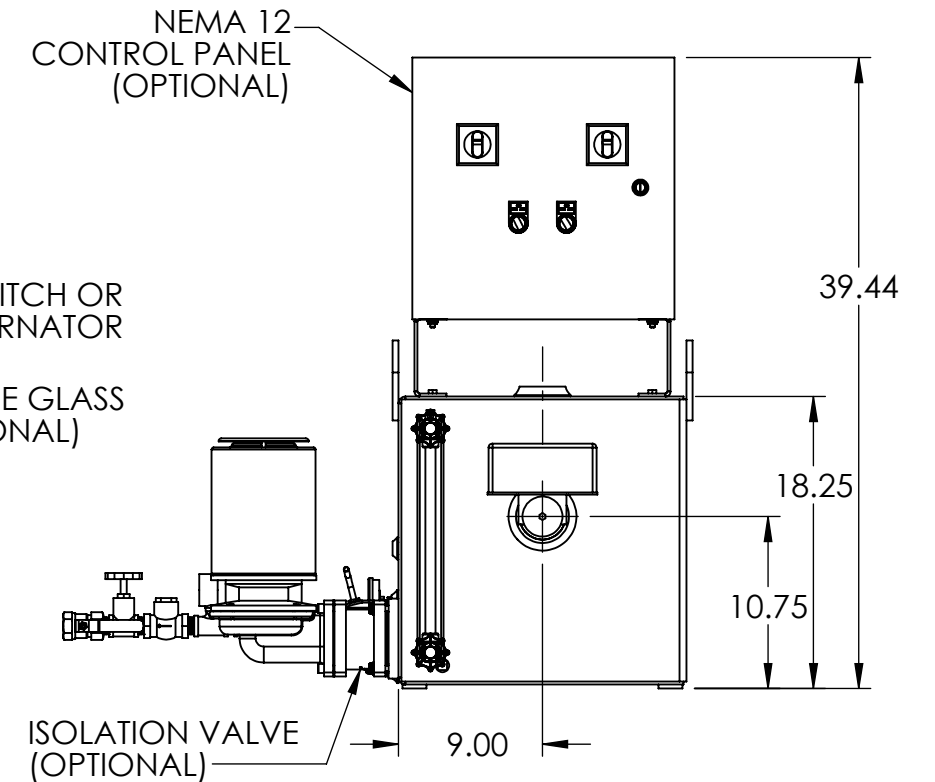
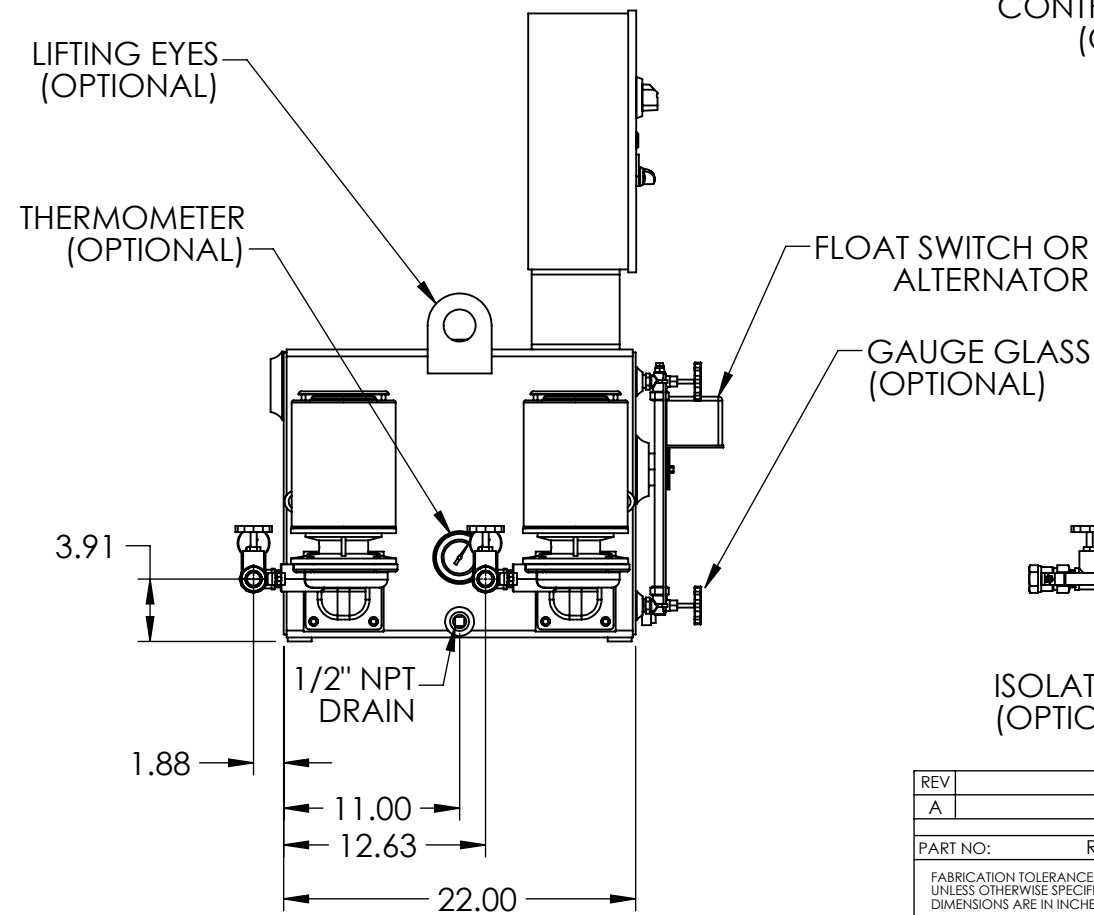
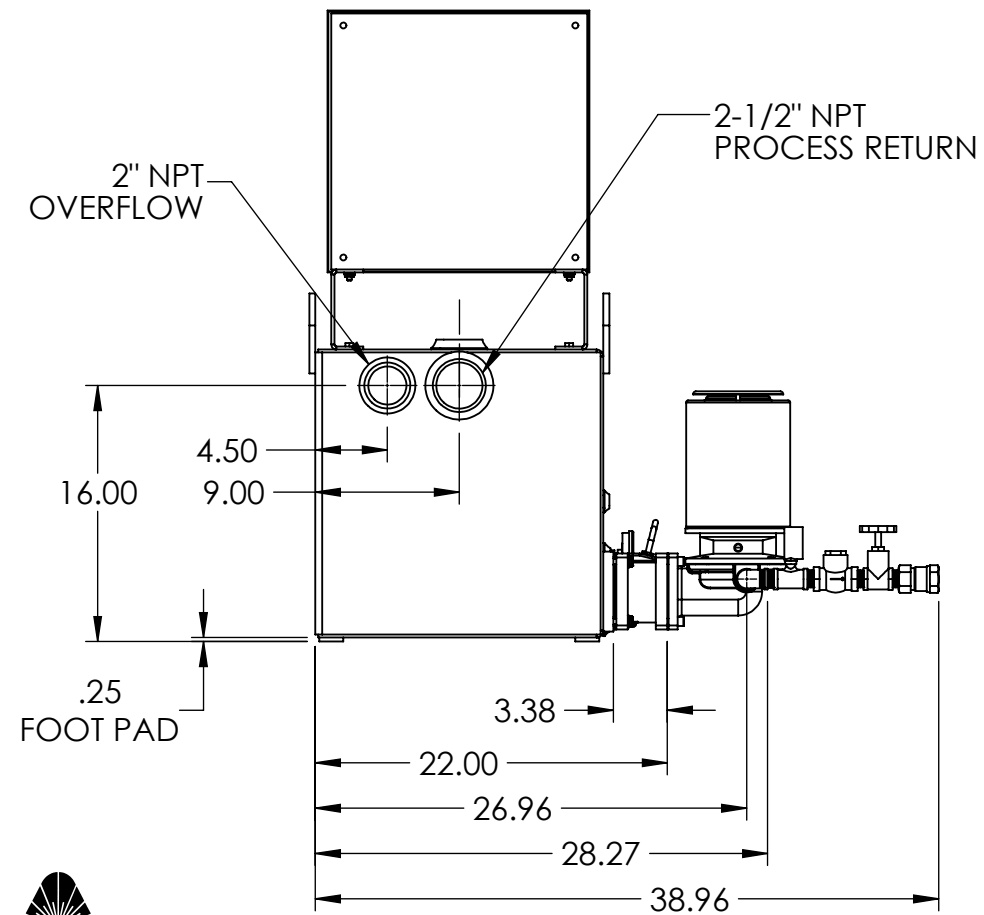
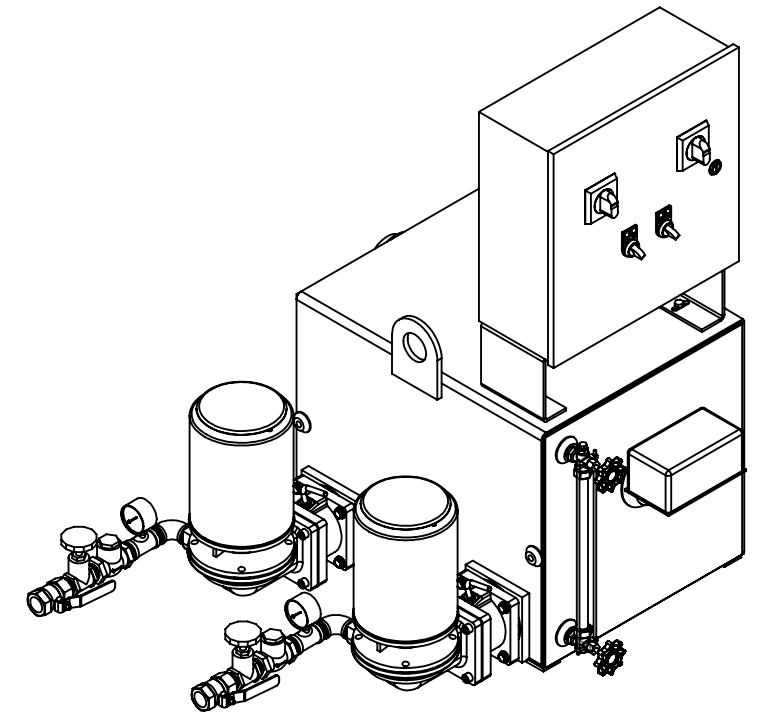
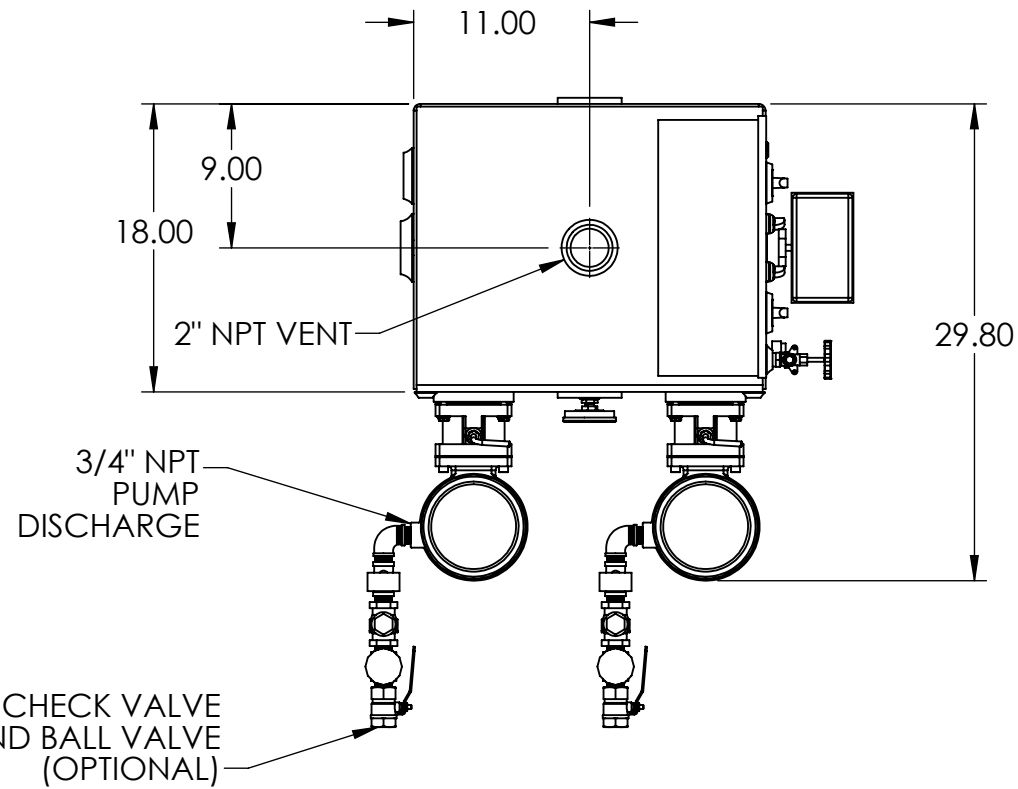

REV	DESCRIPTION	ECN	NAME	DATE
A	Initial Design		GJM	3/16/2018

PART NO:	Ref PartNo	NAME	DATE
		GJM	3/16/2018

FABRICATION TOLERANCES UNLESS OTHERWISE SPECIFIED: DIMENSIONS ARE IN INCHES	DRAWN	THIRD ANGLE PROJECTION
TOLERANCES: ANGULAR DIMENSIONS $\pm 1^\circ$ FRACTIONS $\pm 1/32$	CHECKED	TITLE
TWO PLACE DECIMAL ± 0.06 THREE PLACE DECIMAL ± 0.030	ENG APPR.	30 GALLON SS DUPLEX 4300 SERIES "G" CONDENSATE PUMP
	PRODUCT FAMILY HTSP Boiler and Condensate	
	PRODUCT CATEGORY	

SHEET: 1 OF 1	WEIGHT	DRAWING MAY NOT BE PRINTED TO SCALE.	DWG NO.	REV
	275.54	SCALE: 1:12	684.43030.00G	A