

NOTES:

- TANK MATERIAL: STAINLESS STEEL
- ALL DIMENSIONS ARE $\pm 0.25"$
- DRAWING NOT FOR CONSTRUCTION
- CONSULT FACTORY AT TIME OF ORDER FOR CURRENT PRINT
- INLET BASKET STRAINER OR Y-STRAINER ALSO AVAILABLE

CONTROL PANEL OPTIONS (NOT SHOWN):

- NEMA 4 OR NEMA 4X OR NEMA 3R CONSTRUCTION
- ELECTRIC ALTERNATOR
- POWER ON LIGHT
- PUMP TEST BUTTON
- PUMP RUN TIME METER
- EXTRA DRY CONTACTS
- UL/CUL LABELED PANEL
- HIGH LEVEL ALARM HORN & LIGHT W/SILENCE SWITCH
- LEAD-AUTO-LAG SELECTOR SWITCH

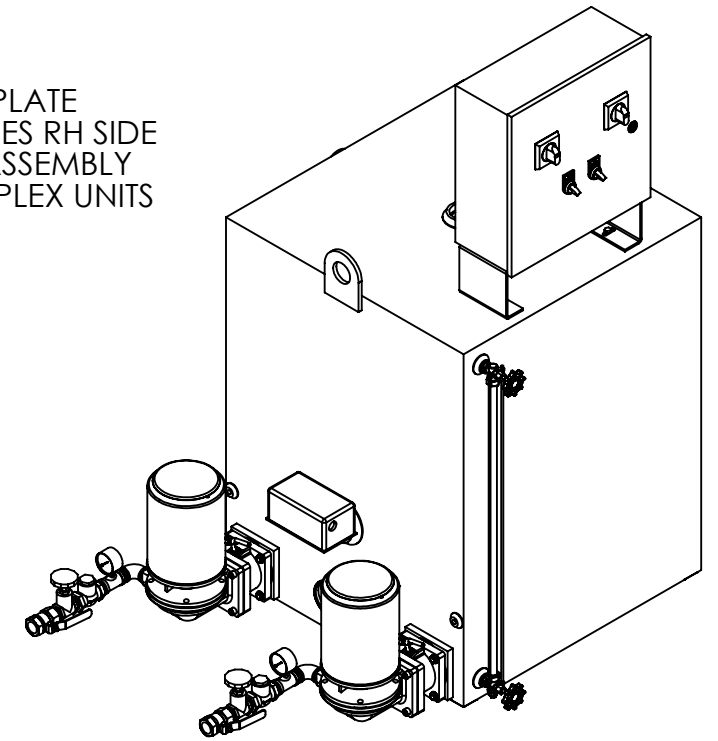
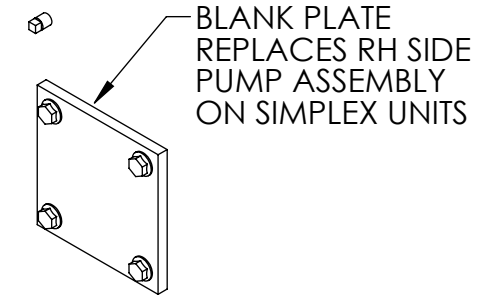
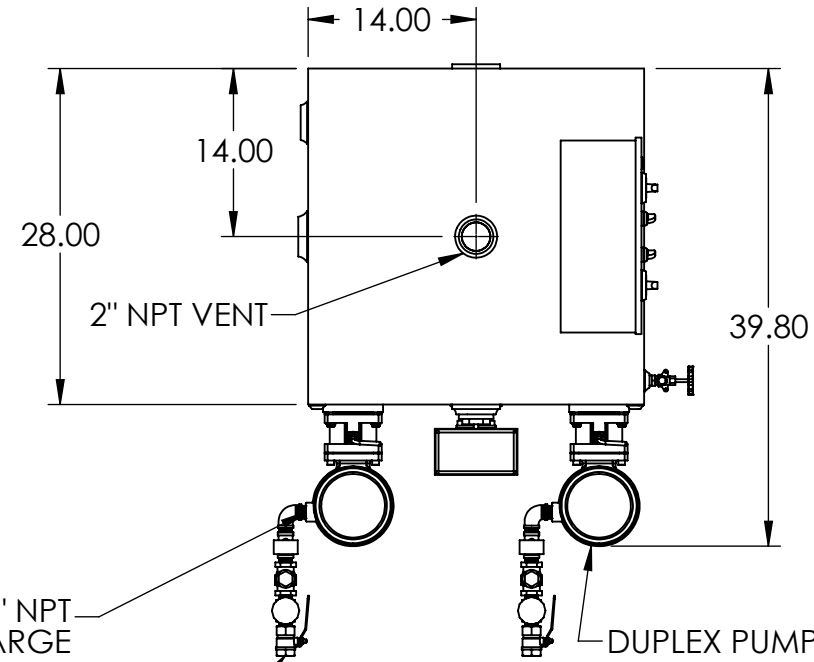

PRESSURE GAUGE, CHECK VALVE
GATE VALVE AND BALL VALVE
(OPTIONAL)

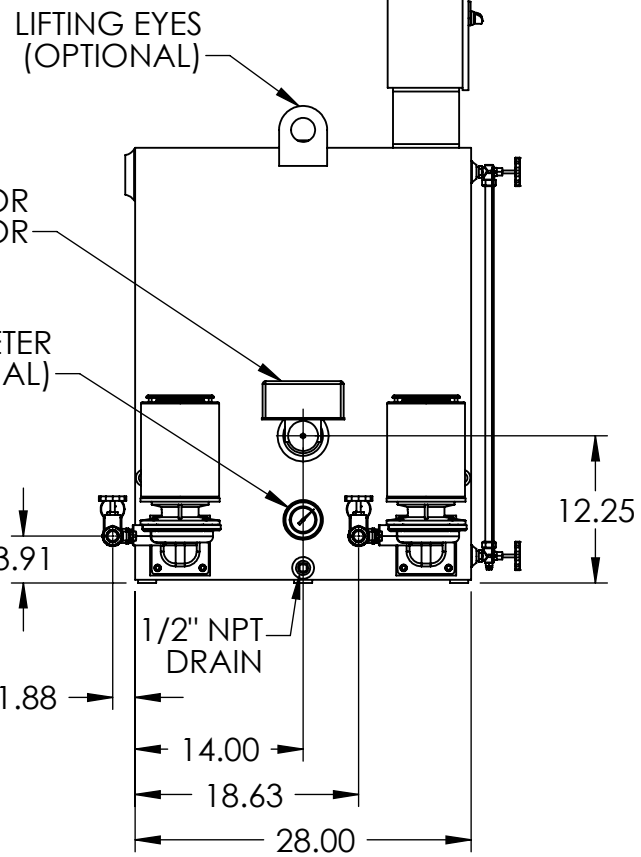
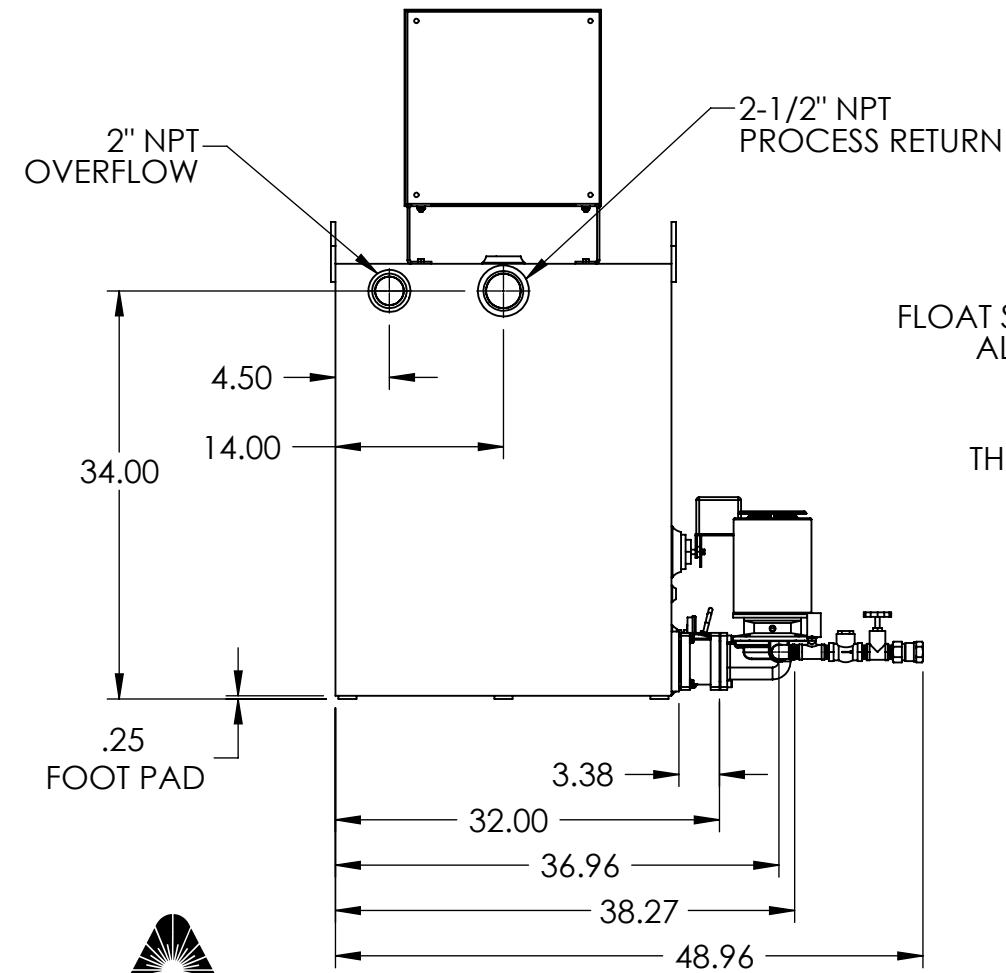

NEMA 12
CONTROL PANEL
(OPTIONAL)

GAUGE GLASS
(OPTIONAL)

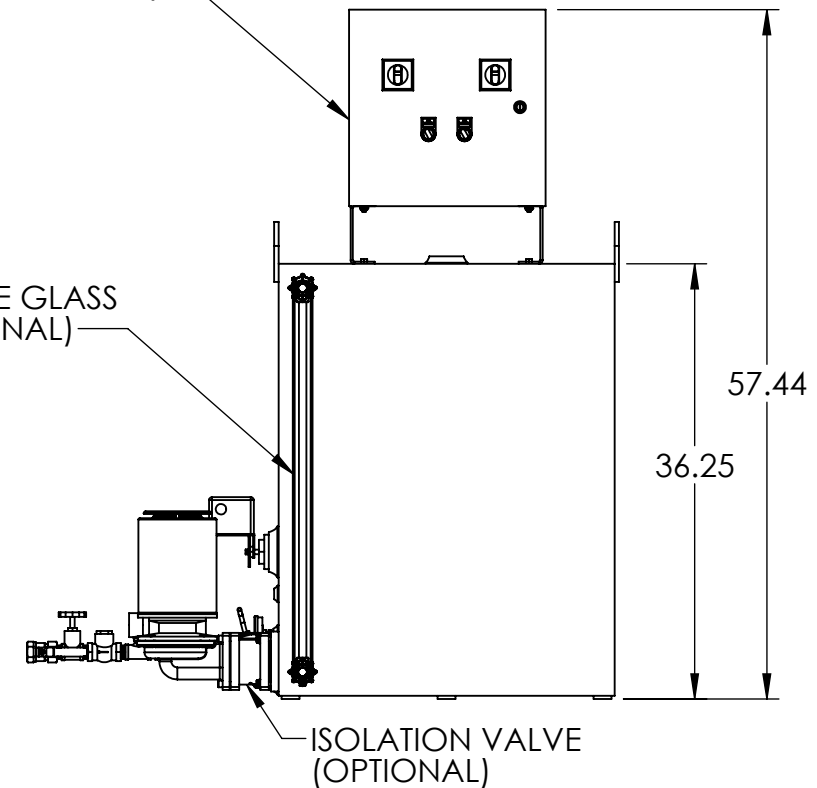

REV	DESCRIPTION	ECN	NAME	DATE
A	Initial Design		GJM	3/16/2018

PART NO:	Ref PartNo	NAME	DATE	 THIRD ANGLE PROJECTION TITLE 120 GALLON SIMPLEX/DUPLEX 4300 SERIES "G" CONDENSATE PUMP
FABRICATION TOLERANCES UNLESS OTHERWISE SPECIFIED: DIMENSIONS ARE IN INCHES	DRAWN	GJM	3/16/2018	
TOLERANCES: ANGULAR DIMENSIONS $\pm 1^\circ$ FRACTIONS $\pm 1/32$	CHECKED			
TWO PLACE DECIMAL ± 0.06 THREE PLACE DECIMAL ± 0.030	ENG APPR.			
		PRODUCT FAMILY	HTSP Boiler and Condensate	
		PRODUCT CATEGORY		
SHEET: 1 OF 1	WEIGHT 551.52	DRAWING MAY NOT BE PRINTED TO SCALE. SCALE: 1:16	DWG NO. 684.43120.00G	REV A