

NOTES:

- TANK MATERIAL: CAST IRON PER ASTM A48 CLASS 30
- ALL DIMENSIONS ARE ±0.25"
- DRAWING NOT FOR CONSTRUCTION
- CONSULT FACTORY AT TIME OF ORDER FOR CURRENT PRINT
- INLET BASKET STRAINER OR Y-STRAINER ALSO AVAILABLE

CONTROL PANEL OPTIONS ALSO AVAILABLE (NOT SHOWN):

- NEMA 4 OR NEMA 4X OR NEMA 3R CONSTRUCTION
- ELECTRIC ALTERNATOR
- POWER ON LIGHT
- PUMP TEST BUTTON
- PUMP RUN TIME METER
- EXTRA DRY CONTACTS
- UL/CUL LABELED PANEL
- HIGH LEVEL ALARM HORN & LIGHT W/SILENCE SWITCH
- LEAD-AUTO-LAG SELECTOR SWITCH

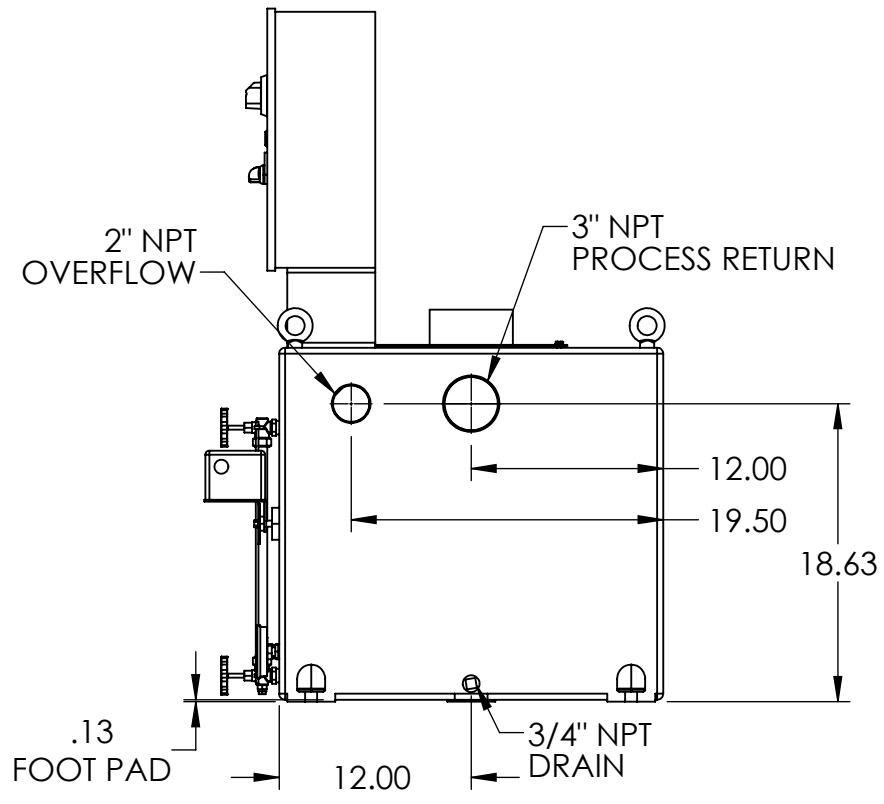
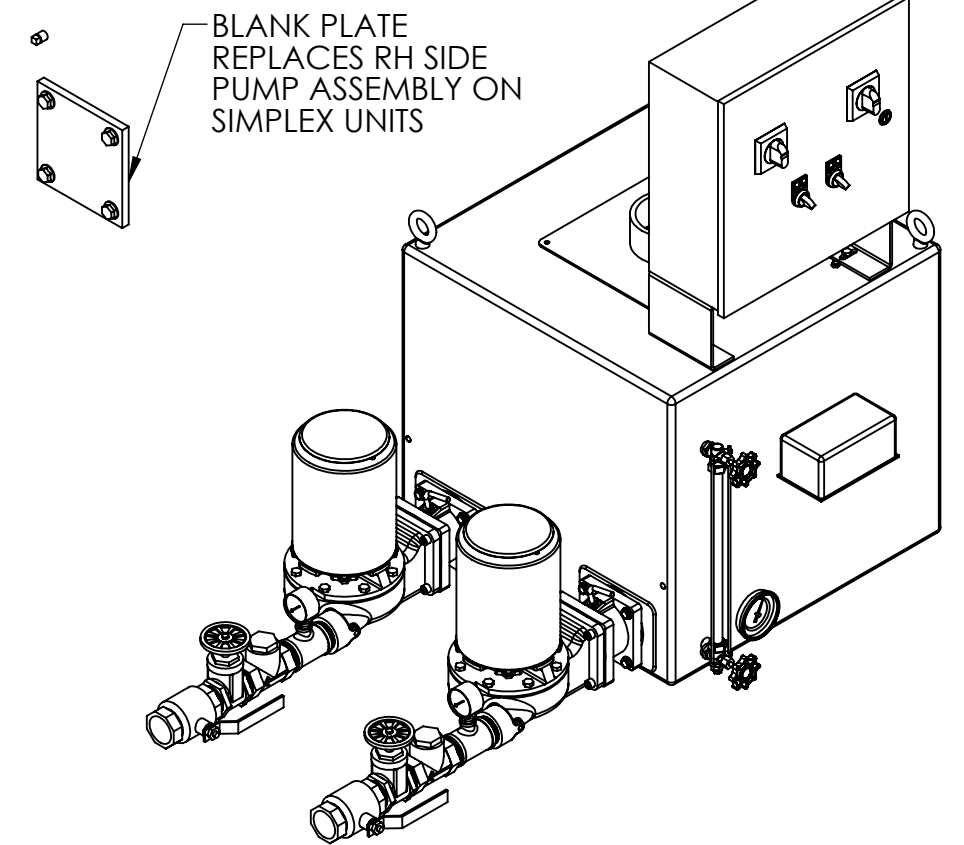
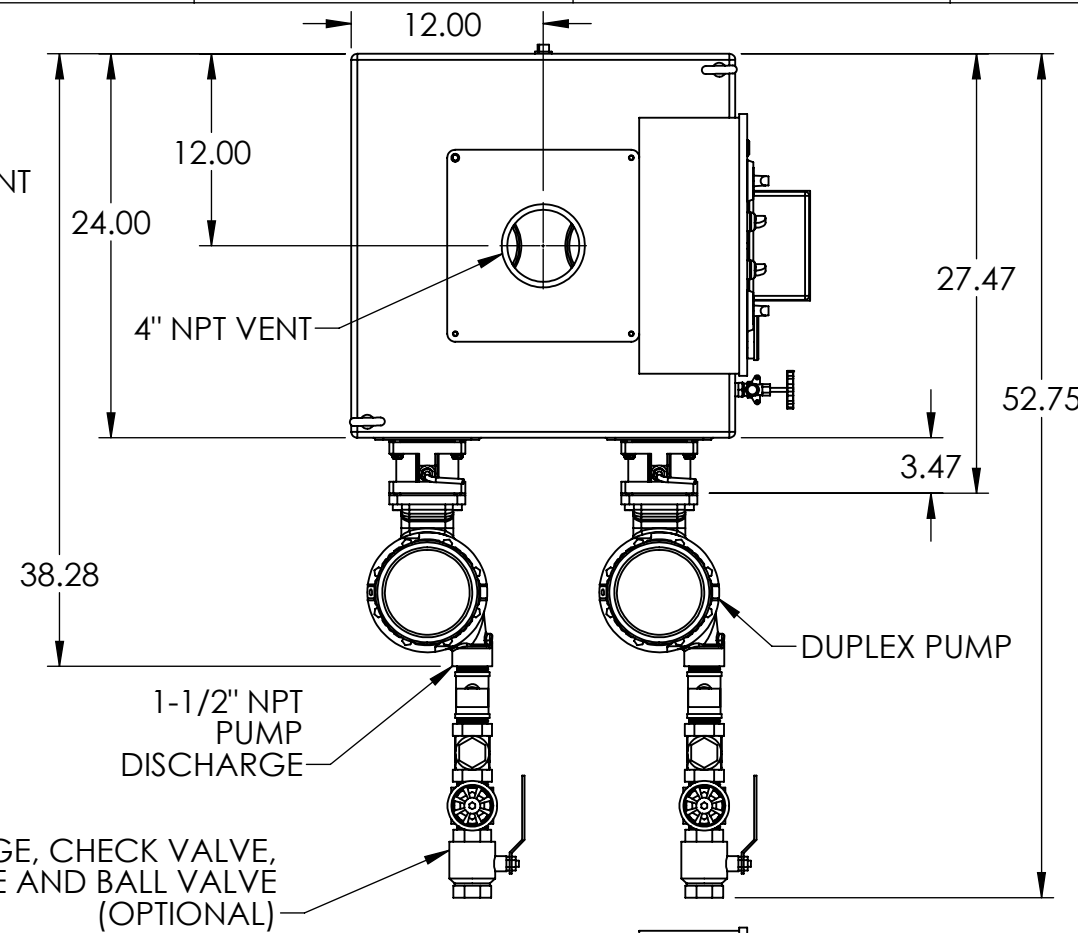

BACK VIEW

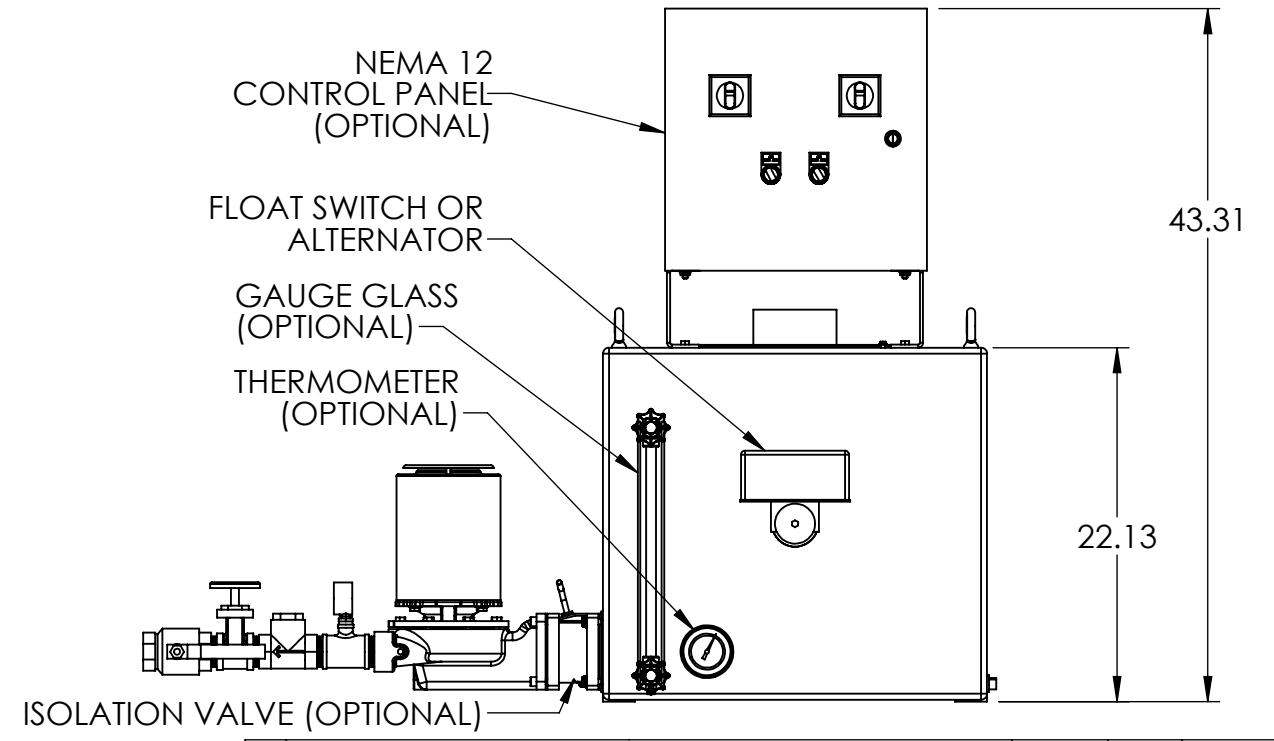
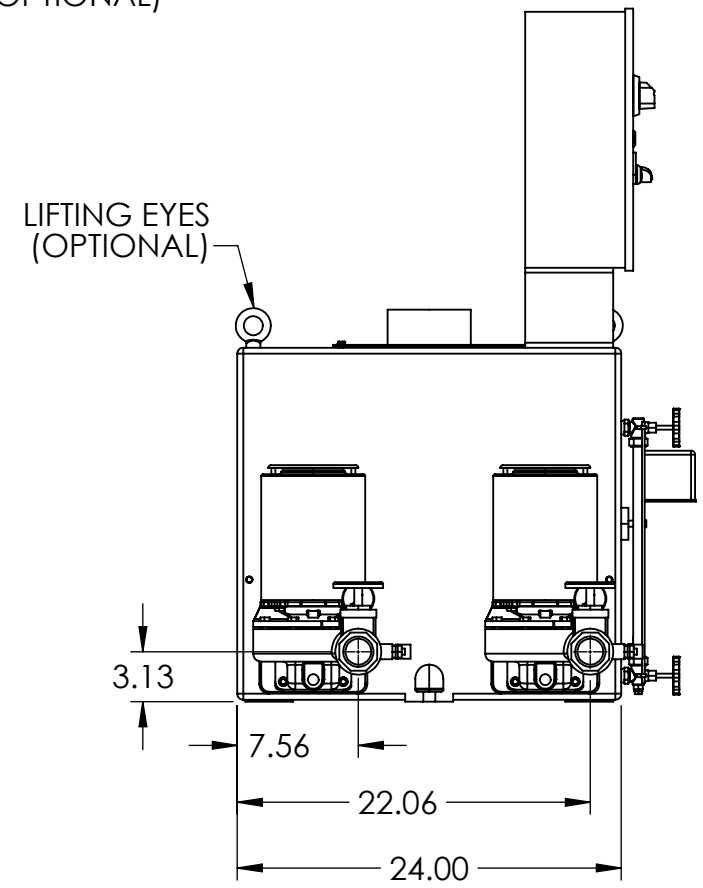

REV	DESCRIPTION	ECN	NAME	DATE
B			GJM	5/10/2018

PART NO:	Ref PartNo	NAME	DATE
FABRICATION TOLERANCES UNLESS OTHERWISE SPECIFIED; DIMENSIONS ARE IN INCHES	DRAWN	GJM	2/19/2016
TOLERANCES: ANGULAR DIMENSIONS ±1° FRACTIONS ±1/32	CHECKED		
TWO PLACE DECIMAL ±0.06	ENG APPR.		
THREE PLACE DECIMAL ±0.030	PRODUCT FAMILY	HTSP Boiler and Condensate	
	PRODUCT CATEGORY	4200	

SHEET: 1 OF 1	WEIGHT	DRAWING MAY NOT BE PRINTED TO SCALE.	DWG NO.	REV
	769.30	SCALE: 1:12	684.42050.00J	B

THIRD ANGLE PROJECTION
TITLE
50 GALLON SIMPLEX/DUPLEX
4200 SERIES
"J" CONDENSATE PUMP