

NOTES:

- TANK MATERIAL: CAST IRON PER ASTM A48 CLASS 30
- ALL DIMENSIONS ARE ± 0.25"
- DRAWING NOT FOR CONSTRUCTION
- CONSULT FACTORY AT TIME OF ORDER FOR CURRENT PRINT
- INLET BASKET STRAINER OR Y-STRAINER ALSO AVAILABLE

CONTROL PANEL OPTIONS ALSO AVAILABLE (NOT SHOWN):

- NEMA 4 OR NEMA 4X OR NEMA 3R CONSTRUCTION
- ELECTRIC ALTERNATOR
- POWER ON LIGHT
- PUMP TEST BUTTON
- PUMP RUN TIME METER
- EXTRA DRY CONTACTS
- UL/CUL LABELED PANEL
- HIGH LEVEL ALARM HORN & LIGHT W/SILENCE SWITCH
- LEAD-AUTO-LAG SELECTOR SWITCH

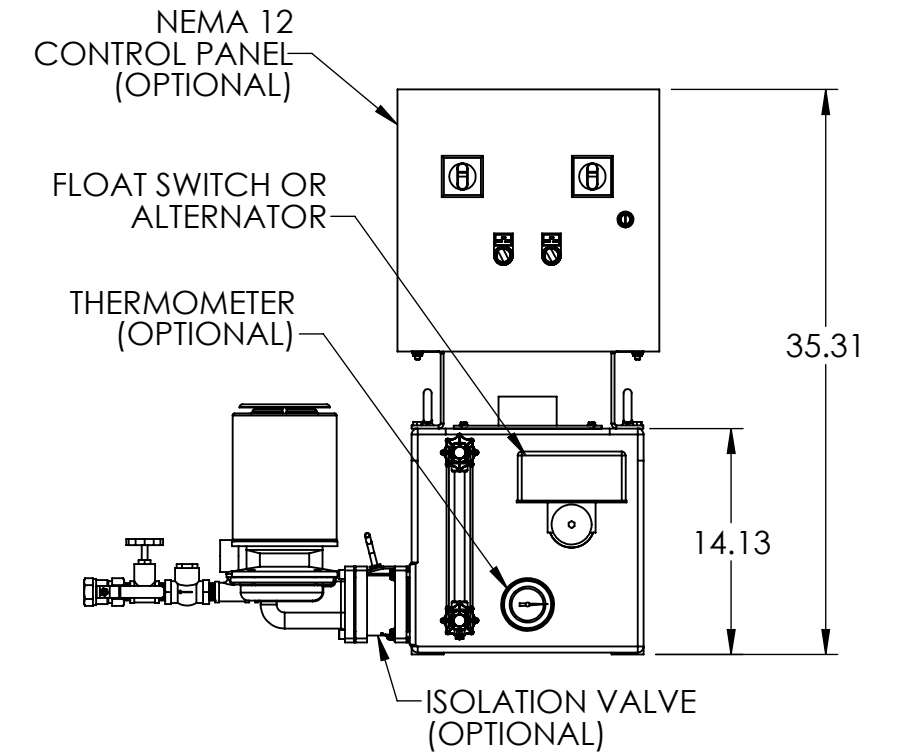
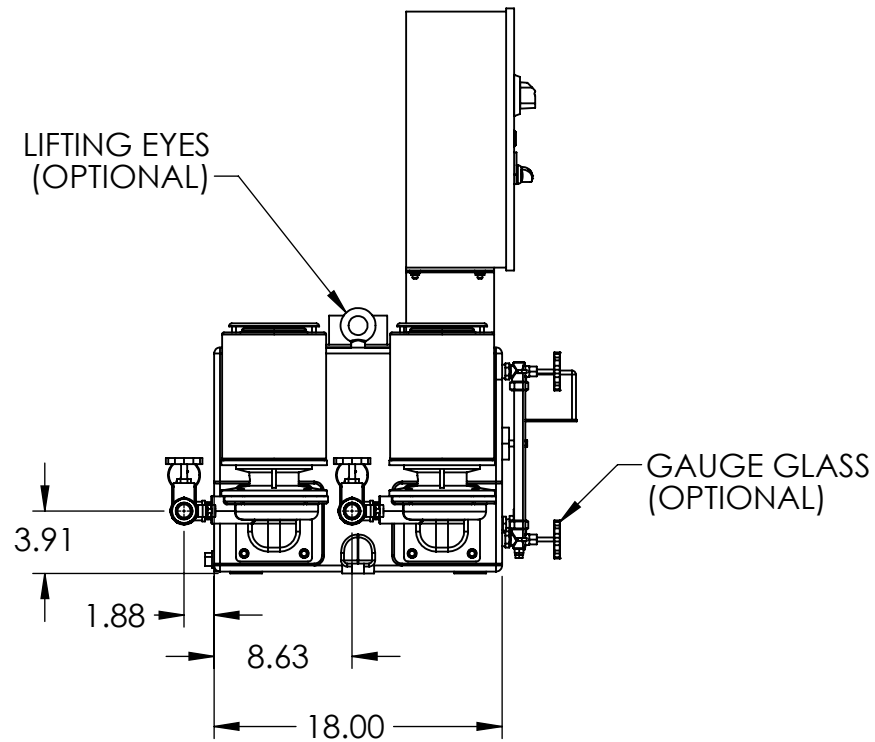
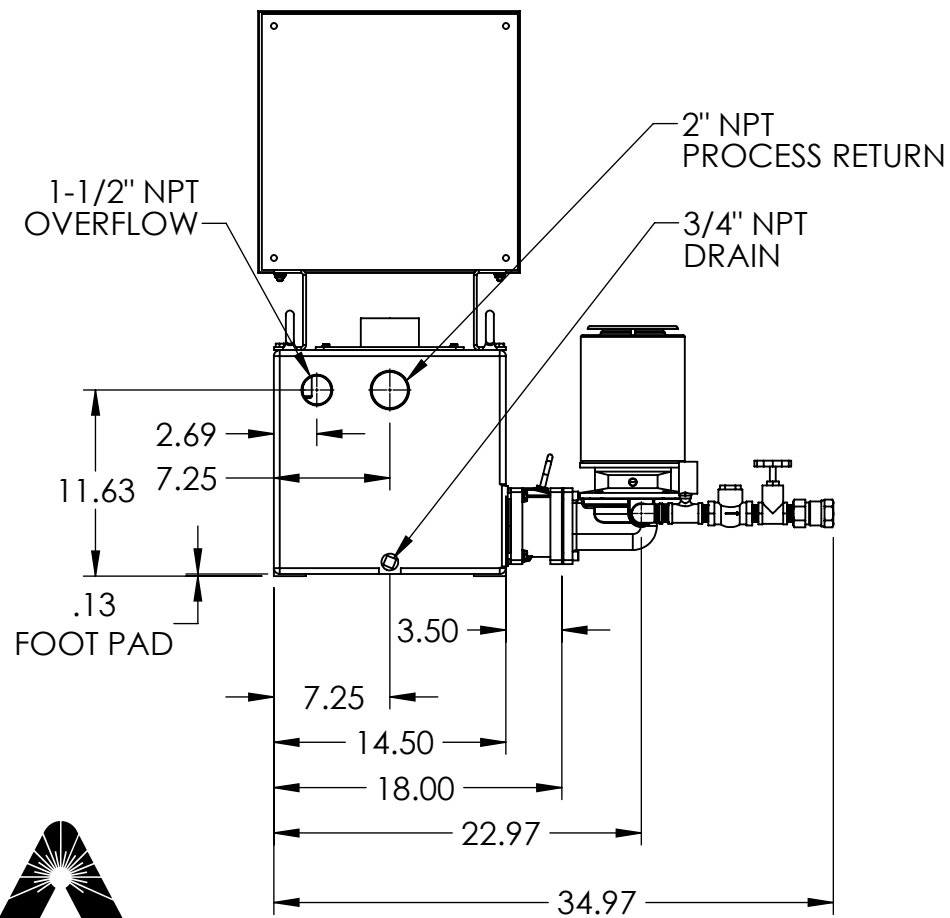
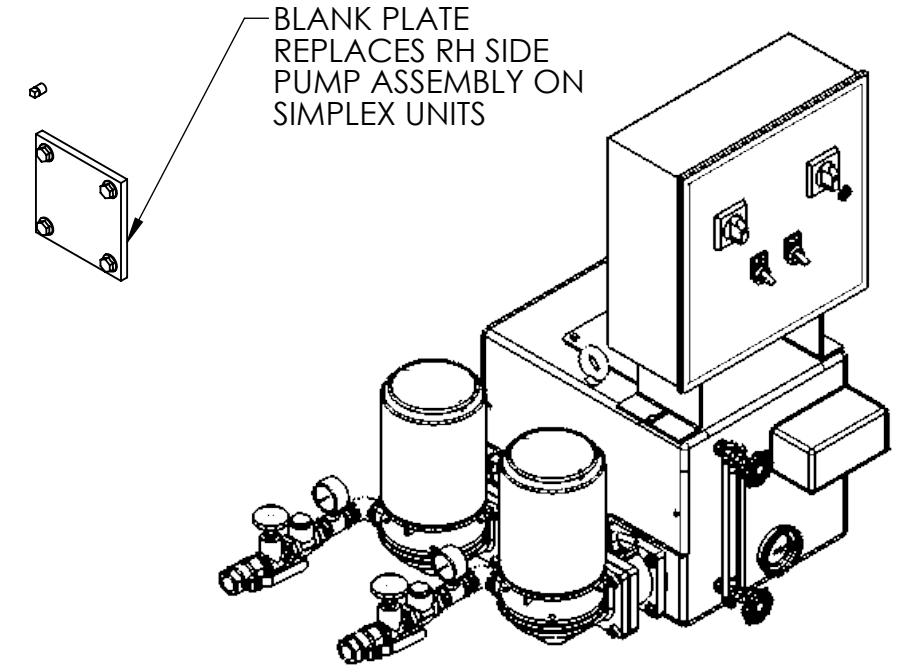
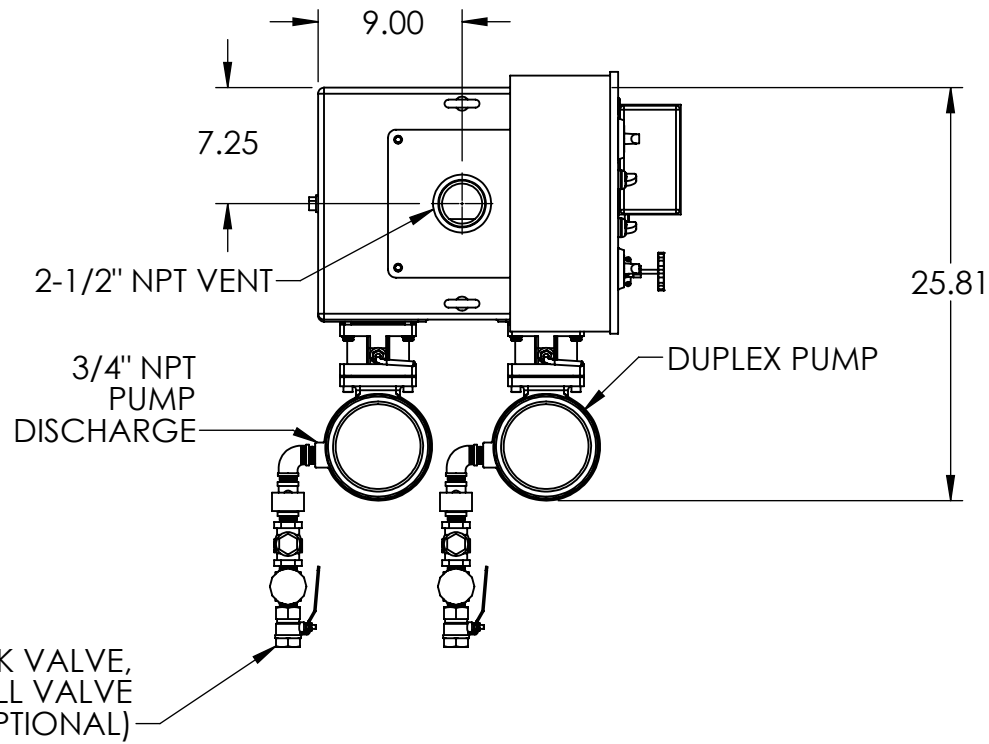

armstronginternational.com

REV	DESCRIPTION	ECN	NAME	DATE
B			GJM	5/9/2018

PART NO:	Ref PartNo	NAME	DATE	 THIRD ANGLE PROJECTION TITLE 15 GALLON SIMPLEX/DUPLEX 4200 SERIES "G" CONDENSATE PUMP
FABRICATION TOLERANCES UNLESS OTHERWISE SPECIFIED: DIMENSIONS ARE IN INCHES	DRAWN	GJM	2/18/2016	
TOLERANCES: ANGULAR DIMENSIONS ±1° FRACTIONS ±1/32	CHECKED			
TWO PLACE DECIMAL ±0.06 THREE PLACE DECIMAL ±0.030	ENG APPR.			
		PRODUCT FAMILY HTSP Boiler and Condensate		
		PRODUCT CATEGORY 4200		
SHEET: 1 OF 1	WEIGHT	DRAWING MAY NOT BE PRINTED TO SCALE. SCALE: 1:12		DWG NO. 684.42015.00G
				REV B