

V200S VERIS Verabar® (Single Rod) Installation and Maintenance Manual



Please read and save
these instructions



Contents

General Safety Information	3
Product Information	3
Section 1: Scope	3
Section 2: Receiving and Inspecting	
Section 3: Safety Precautions	3
 Safety Messages and Application Requirements	3
Section 4: Installation Preparations	3-5
Location	3
Orientation	4
Horizontal Piping	4
Vertical Piping	5
DP Transmitter/Local Indicator Location	5
Installation Drawings and Bill of Materials	5
Piping Support	5
Section 5: Installation Procedure	6-9
Assemble the Verabar®	6
Insert Instrument Vales or Manifold	6
Valves	6
Manifold	6
Retract Sensor and Tighten Packing	7
Weld Thread-o-let to Pipe	7
Install Close Nipple & Access Valve	7
Drill Hole in Pipe	7
Mount Sensor Assembly to Access Valve	8
Vent Access Valve to Verify No Leaks are Present	8
Grease Drive Rod	8
Insert Verabar® Sensor Assembly	8
Orientation of Flow Arrow	9
Section 6: Proper Installation	10
Section 7: Periodic Maintenance	10
Limited Warranty and Remedy	11

General Safety Information

Instructions and procedures listed in this manual may require special precautions to ensure the safety of the individuals performing the operations. **Review the entire manual, taking note of safety messages prior to performing any operations listed in the manual.**

Product Information

The VERIS Verabar® averaging pitot flow sensor provides unsurpassed accuracy and reliability. With its solid, one-piece construction and bullet shape the VERIS Verabar® makes flow measurement reliable and precise.

The unique sensor shape reduces drag and flow induced vibration. The location of the low-pressure ports eliminates the potential for clogging and improves signal stability.

The V200S model can be inserted and removed from service under pressure. It features a single drive rod and threaded mounting components.

Section 1 Scope

These instructions provide a description of procedures for installing the V200S (Single Rod) Verabar® flow sensor. Procedures are given for all industrial flow measurement applications including liquid, steam and gas for both horizontal and vertical piping configurations.

Section 2 Receiving Inspection

The following tasks should be performed as part of the receiving inspection procedure:

- Check items received against the packing list.
- Check sensor nameplate for proper model number, serial number and tag number.
- Verify the actual pipe diameter matches the ID stated on the sensor nameplate.
- Check the bullet shaped sensor tube for any signs of damage. Damage to the sensor tube may result in erroneous flow readings.
- Check the round cover tube for any damage, especially axial gouges or scratches. Damage to the cover tube may prevent the packing from sealing properly.

Section 3 Safety Precautions

The following process should be conducted prior to installing the Verabar® flow sensor:

- Check the maximum operating conditions on the flow sensor nameplate. If any pressure, temperature or flow limits will be exceeded, contact the factory before proceeding.

Section 4 Installation Preparations

4.1 Location

For the most accurate flow measurement, a minimum straight run of pipe is required. Table 1 shows the minimum straight run requirements. If longer straight runs are available, position the Verabar® such that the ratio of upstream straight run to downstream straight run is approximately 4 to 1. If straight run lengths are less than the values stated in Table 1, contact Armstrong's VERIS Flow Measurement Group directly. Straightening vanes should be positioned such that the end closest to the Verabar® is half way between the Verabar® and the closest upstream configuration. For elbow installations, mount the Verabar® in the same plane as the closest upstream elbow.

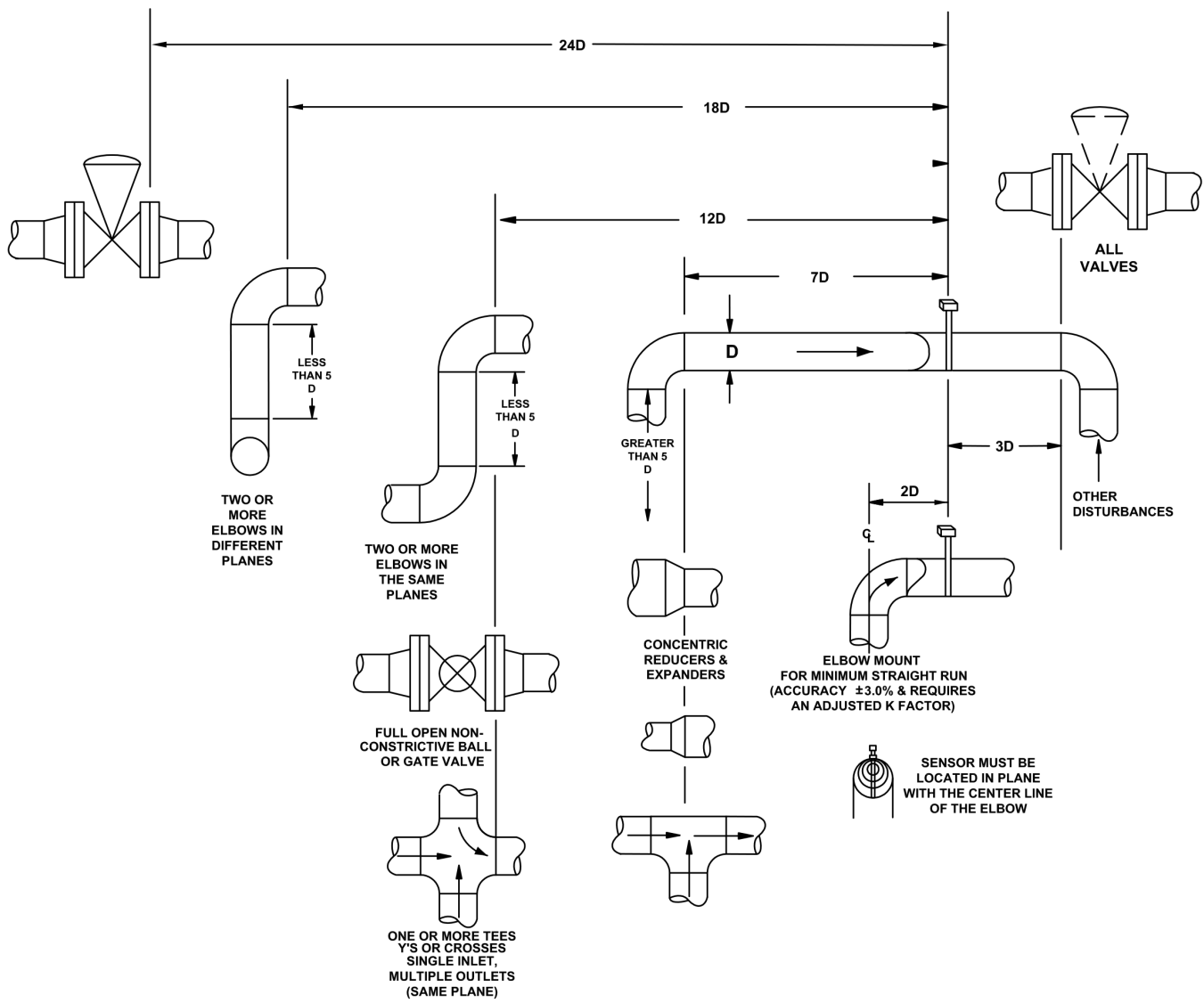

Table 1. Straight Run Requirements

4.2 Orientation

Verify the proper sensor orientation by checking for an “-H” (horizontal piping) or a “-V” (vertical piping) in the model number on the Verabar® name plate. Verify that the flow arrow stamped on the instrument head is pointing downstream in the direction of flow.

4.2.1 Horizontal Piping

For air or gas installations, mount the Verabar® in the upper 160° of the pipe to allow any condensate to drain into the pipe (Figure 1). For liquid or steam installations, mount the Verabar® in the lower 160° of the pipe. This allows any entrained air to bleed back into the pipe for liquid applications and allows condensate to collect in the instrument piping for steam applications.

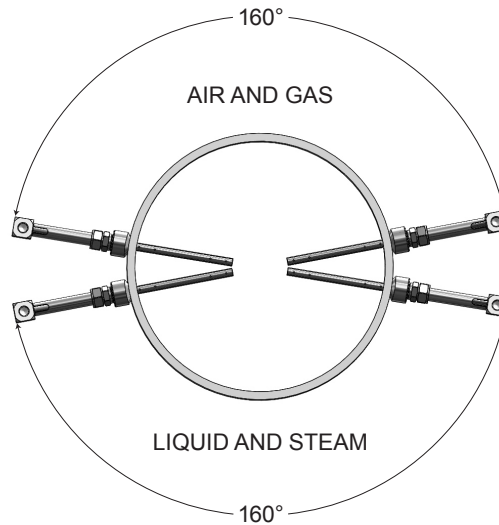

Figure 1. Verabar® Orientation in Horizontal Pipe

4.2.2 Vertical Piping

The Verabar® may be mounted in any location around the circumference of the pipe for vertical piping applications.

4.3 DP Transmitter/Local Indicator Location

When choosing a Verabar® location, consider the DP transmitter/local indicator location:

- The transmitter must be mounted below the Verabar® for liquid and steam applications.
- The transmitter must be mounted above the Verabar® for air and gas applications.

4.4 Installation Drawings and Bill of Materials

Additional information is available in the Installation Drawings and Bill of Materials VB-7061. (Contact factory for access information). It contains standard and alternate transmitter locations and a complete bill of materials based on the fluid type and sensor orientation on the pipe.

4.5 Piping Support

For sensors that extend more than 36" (915mm) beyond the pipe wall or for sensors mounted in thin-walled pipes, external support of the Verabar® is recommended. This will reduce stresses on the pipe wall.

Section 5 Installation Procedure

5.1 Assemble The Verabar®

Your Verabar® is shipped loosely assembled and is not properly tightened for proper pressure retention. Follow all assembly steps to ensure a safe installation (see Figure 2).

5.2 Insert Instrument Vales or Manifold

5.2.1 Valves

- If the Verabar® does not have a valve head, install instrument valves using proper thread sealant. Be sure instrument shut-off valves are installed and shut prior to re-pressurizing the pipe.

5.2.2 Manifold

- If the Verabar® has a direct or integral manifold, be sure the high and low pressure block valves are shut off prior to re-pressurizing the pipe.

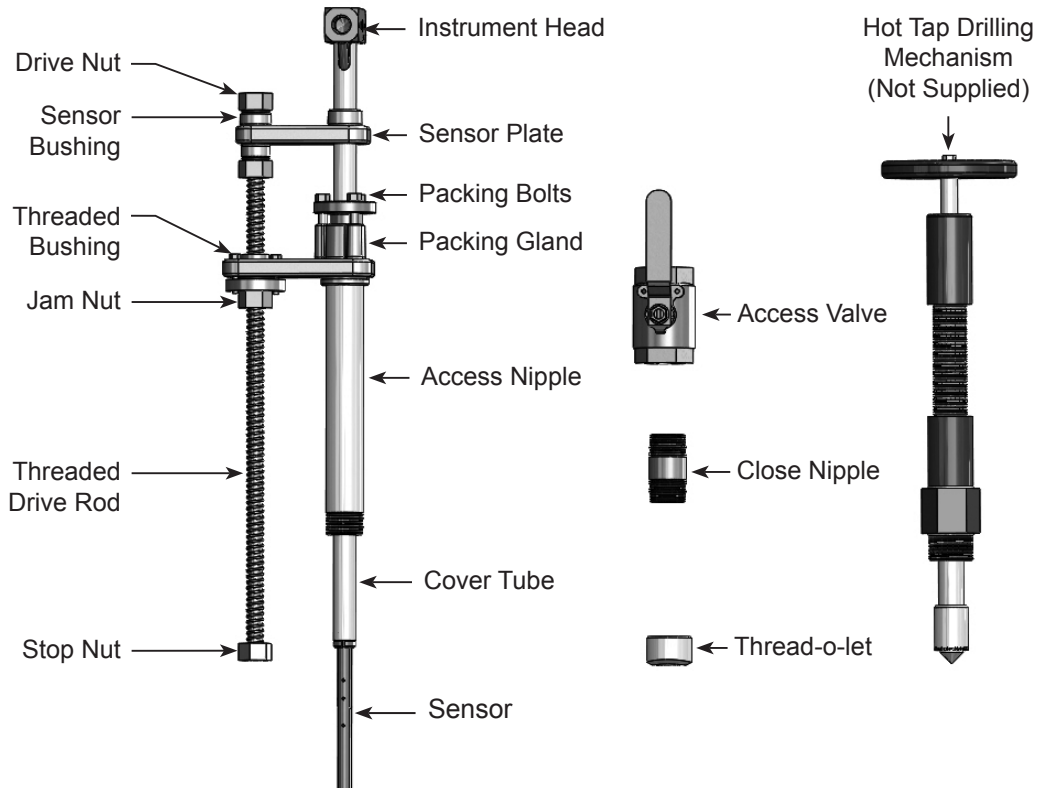

Figure 2. Verabar® Model V200S (Single Rod)

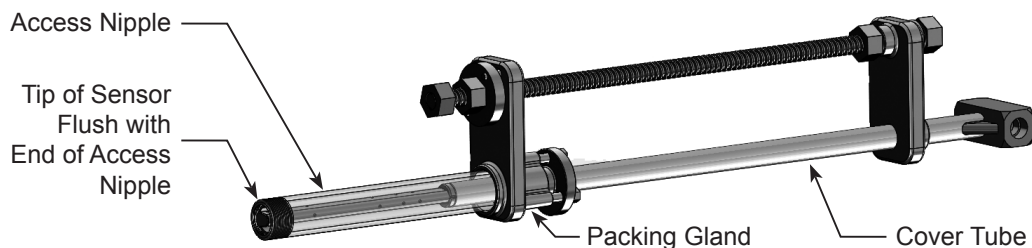

Figure 3. Access Nipple

5.3 Retract Sensor and Tighten Packing

- Retract the Verabar® such that the tip of the sensor is flush with the end of the access nipple (Figure 3). Tighten the three packing bolts on the packing gland.

5.4 Weld Thread-o-let to Pipe

- Mark the location where the Verabar® is to be mounted. Position the Thread-o-let over the center of the mark. Using the appropriate weld gap (1/16" [1.5mm] typical), tack weld the Thread-o-let into position. Protect threads on the Thread-o-let, then finish welding the Thread-o-let to the pipe per applicable codes.

5.5 Install Close Nipple & Access Valve

- Using the appropriate pipe thread sealant, install close nipple and access valve. Orient the valve (Figure 4) such that for horizontal pipes the valve handle is in-line (perpendicular for vertical pipes) with the centerline of the pipe. Be sure the valve handle does not hit the pipe during opening and closing of the valve. Verify that the close nipple and access valve are properly tightened, because beyond this point, they will not be serviceable without depressurizing the line.

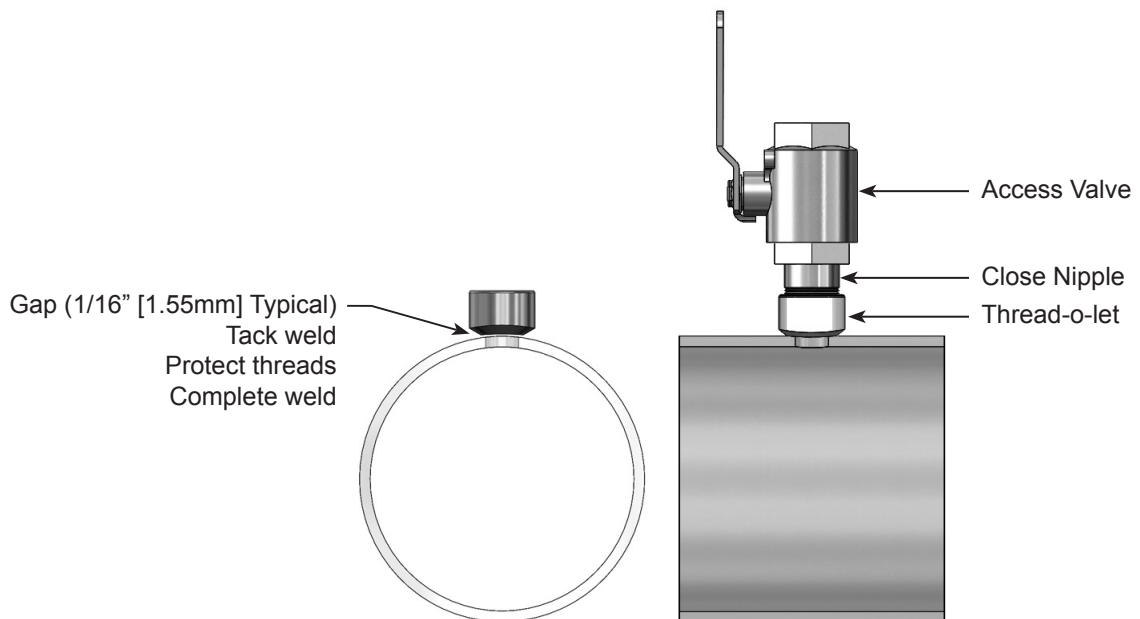

Figure 4. Weld Gap

5.6 Drill Hole in Pipe

- With the access valve in the full open position, install an appropriate Hot Tap Drilling Machine (Figure 5) and drill a hole in the pipe (hole sizes per chart below). Follow the instructions given by the Hot Tap Drilling Machine.

Sensor Size	Hole Diameter
V200S-05	½" [13mm]
V200S-10	1" [25mm]
V200S-15	1 ½" [38mm]

- After the hole is completely drilled, retract the Hot Tap Drilling Machine. Shut off the access valve prior to removal of the Hot Tap Drilling Machine.

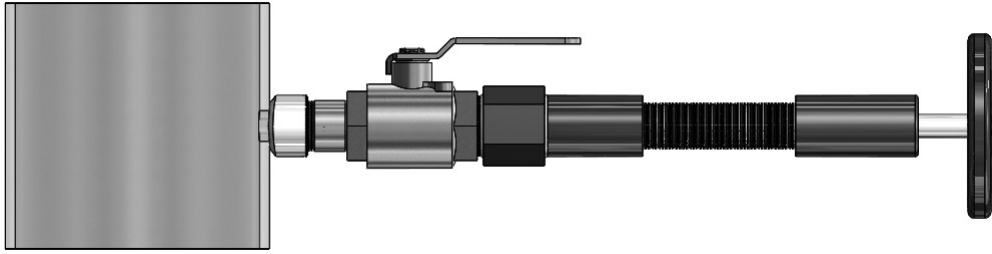

Figure 5. Hot Tap Drilling Machines

5.7 Mount Sensor Assembly to Access Valve

Apply appropriate thread sealant to the access nipple and thread the access nipple into the access valve. Orient the sensor such that the arrow labeled “FLOW” on the instrument head is in the direction of the flow in the pipe within 3° (orientation per Figure 6).

5.8 Vent Access Valve to Verify No Leaks are Present

With the instrument valves shut, slowly crack open the access valve and verify that there are no process fluid leaks. If leaks are present, shut off the access valve and tighten the leaky joint.

5.9 Grease Drive Rod

- High temperature grease has been applied to the threaded rod at the factory. Verify the threaded rod is adequately greased prior to inserting the sensor. If necessary, smear grease on the threaded drive rod. A high temperature grease should be used on all steam applications and for temperatures above 200°F.
- Grease should be applied prior to subsequent insertions and retractions.

5.10 Insert Verabar® Sensor Assembly

Warning: The flow rate must be decreased to the maximum insertion/withdrawn DP/flow limit stated on the Verabar® nameplate.

- The Verabar® should be oriented such that the arrow on the head is pointing in the direction of the flow.
- Completely open the access valve. Then, using the drive nut, insert the sensor.
- The tip of the sensor should completely bottom on the opposite end of the pipe. Continue to insert the sensor until firm resistance is met. This will occur when the sensor plate is approximately 2” [51mm] from the top of the packing gland.
- Thread the jam nut toward the threaded bushing. The jam nut should press tightly against the threaded bushing. This will lock the drive rod in place and maintain the sensor position in the pipe.

Vertical Pipe Orientations

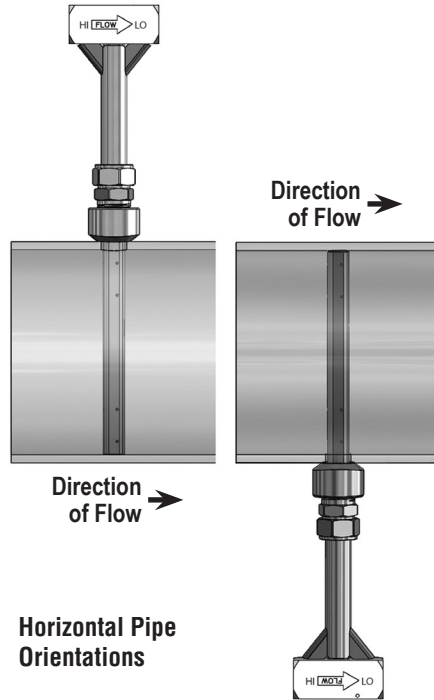
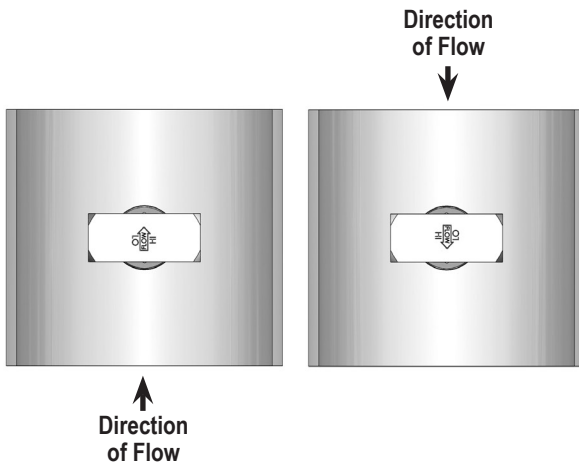

Figure 6. Orientation of Flow Arrow

Verabar® is now properly installed (Figure 7)

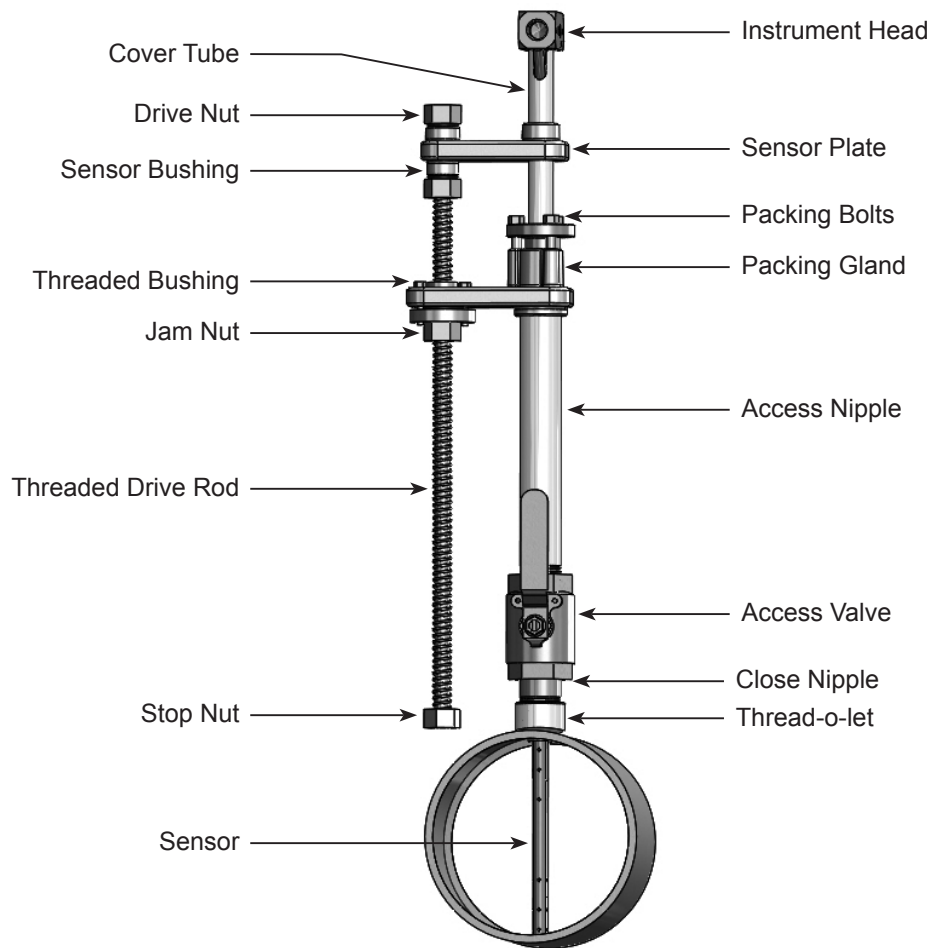

Figure 7. Installed V200S (Single Rod)

Section 6 Periodic Maintenance

The assembly should be periodically checked. Verify that no leaks are present. The jam nut and packing bolts should be tight.

Section 7 Sensor Removal Procedure

- Shut off instrument valves
- Reduce flow rate below the maximum insertion/withdrawn DP/flow limit stated on the Verabar® nameplate.
- Loosen jam nut.
- Using the drive nut, retract the sensor until the stop nut and jam nut are pressing against the threaded bushing.
- Completely shut off the access valve. Slowly crack open one of the Verabar® instrument valves and bleed off any remaining pressure contained in the access nipple. The sensor assembly can now be removed.

VERIS, Inc.

Limited Warranty and Remedy

VERIS, Inc. (“VERIS”) warrants to the original user of those products supplied by it and used in the service and in the manner for which they are intended shall be free from defects in material and workmanship for a period of five (5) years from the date of installation, but not longer than 63 months from the date of shipment from the VERIS factory, unless a Special Warranty Period applies, as noted below. This warranty does not extend to any product that has been subject to misuse, neglect or alteration after shipment from the VERIS factory. Except as may be expressly provided in a written agreement between VERIS and the user, which is signed by both parties, VERIS **DOES NOT MAKE ANY OTHER REPRESENTATIONS OR WARRANTIES, EXPRESS OR IMPLIED, INCLUDING, BUT NOT LIMITED TO, ANY IMPLIED WARRANTY OF MERCHANTABILITY OR ANY IMPLIED WARRANTY OF FITNESS FOR A PARTICULAR PURPOSE.**

The sole and exclusive remedy with respect to the above limited warranty or with respect to any other claim relating to the products or to defects or any condition or use of the products supplied by VERIS, however caused, and whether such claim is based upon warranty, contract, negligence, strict liability, or any other basis or theory, is limited to VERIS’ repair or replacement of the part or product, or, at VERIS’ option, to repayment of the purchase price. In addition to replacing any part of parts found to VERIS’ satisfaction to be defective, VERIS will pay the cost of shipment of both the defective part to the VERIS plant and the replacement part to the original user. As a condition of enforcing any rights or remedies relating to VERIS products, notice of any warranty or other claim relating to the products must be given in writing to VERIS: (i) within 30 days of last day of the applicable warranty period, or (ii) within 30 days of the date of the manifestation of the condition or occurrence giving rise to the claim, whichever is earlier. **IN NO EVENT SHALL VERIS BE LIABLE FOR SPECIAL, DIRECT, INDIRECT, INCIDENTAL OR CONSEQUENTIAL DAMAGES, INCLUDING, BUT NOT LIMITED TO, LOSS OF USE OR PROFITS OR INTERRUPTION OF BUSINESS.** The Limited Warranty and Remedy terms herein apply notwithstanding any contrary terms in any purchase order or form submitted or issued by any user, purchaser, or third party and all such contrary terms shall be deemed rejected by VERIS.

Special Warranty Periods are as follows:

Electronic components, including without limitation, differential pressure transmitters, multivariable transmitters, flow computers, rate or totalizer displays: one (1) year from the date of installation, but not longer than 15 months from the date of shipment from the VERIS factory.

V200S VERIS Verabar[®] (Single Rod) Installation and Maintenance Manual

*Designs, materials, weights and performance ratings are approximate and subject to change without notice.
Visit armstronginternational.com for up-to-date information.*



Armstrong International - VERIS Flow Measurement Group
5820 Glacier Way, Frederick, CO 80205 - USA Phone: 303-652-8550 Fax: 303-652-8552
armstronginternational.com