

Orifice Plate Installation and Operation Manual

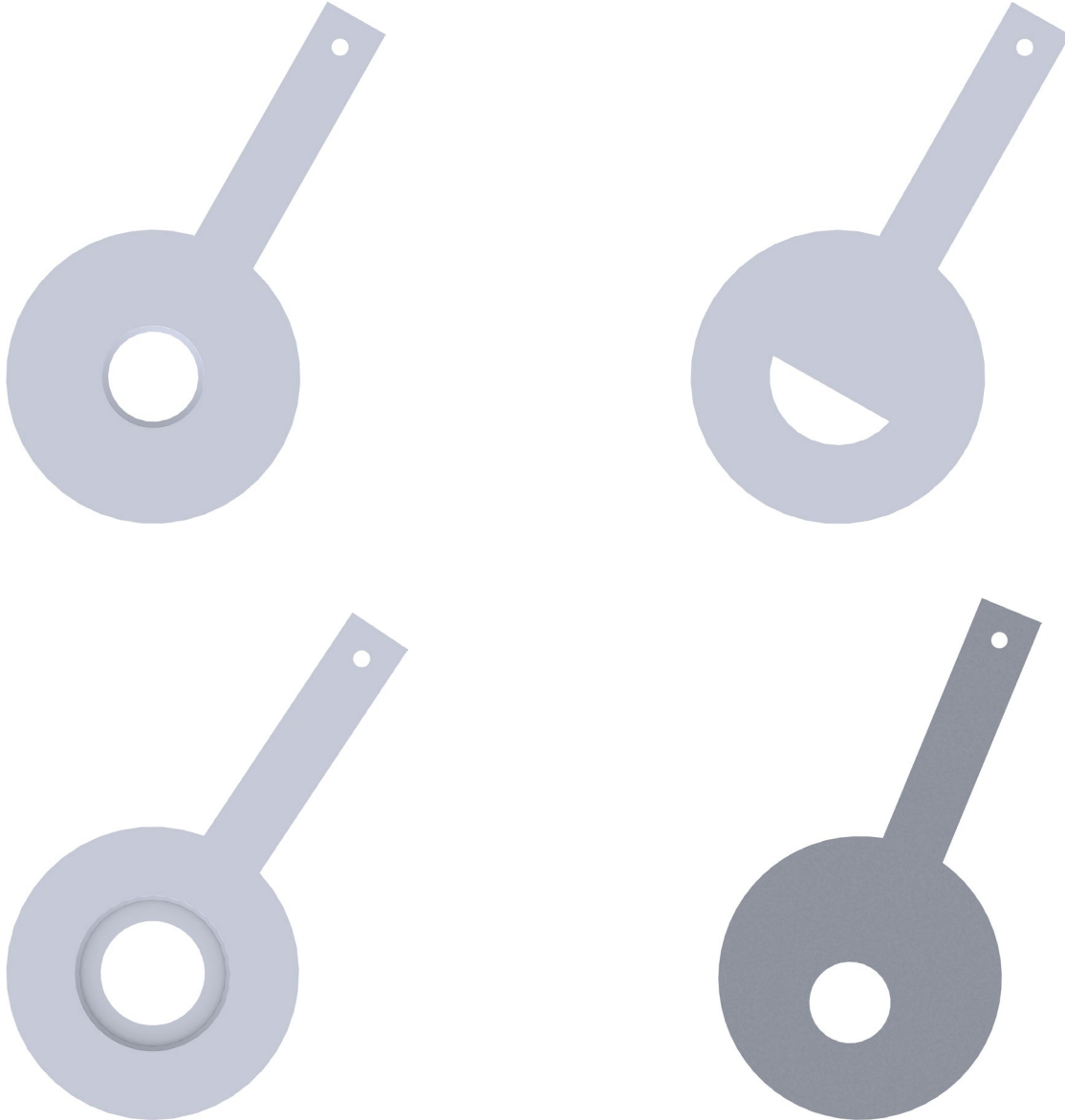

**Please read and save
these instructions.**

Installation Procedures

The Proper Method of Installing Orifice Plates

TO REMOVE ORIFICE PLATE:

- 1.) LOOSEN ALL STUDS AND REMOVE THE TOP HALF OF THE STUDS.
- 2.) SPREAD FLANGES APART BY TURNING JACKBOLTS CLOCKWISE.
- 3.) REMOVE ORIFICE PLATE FOR INSPECTION OR REPLACEMENT.

TO INSTALL ORIFICE PLATE:

- 1.) PLACE ORIFICE PLATE AND GASKETS BETWEEN FLANGES.
- 2.) RELEASE THE FLANGES BY TURNING THE TWO JACKBOLTS COUNTERCLOCKWISE.
- 3.) TIGHTEN ALL STUDS.
- 4.) GASKETS SHOULD BE REPLACED AT EACH ORIFICE PLATE INSPECTION.

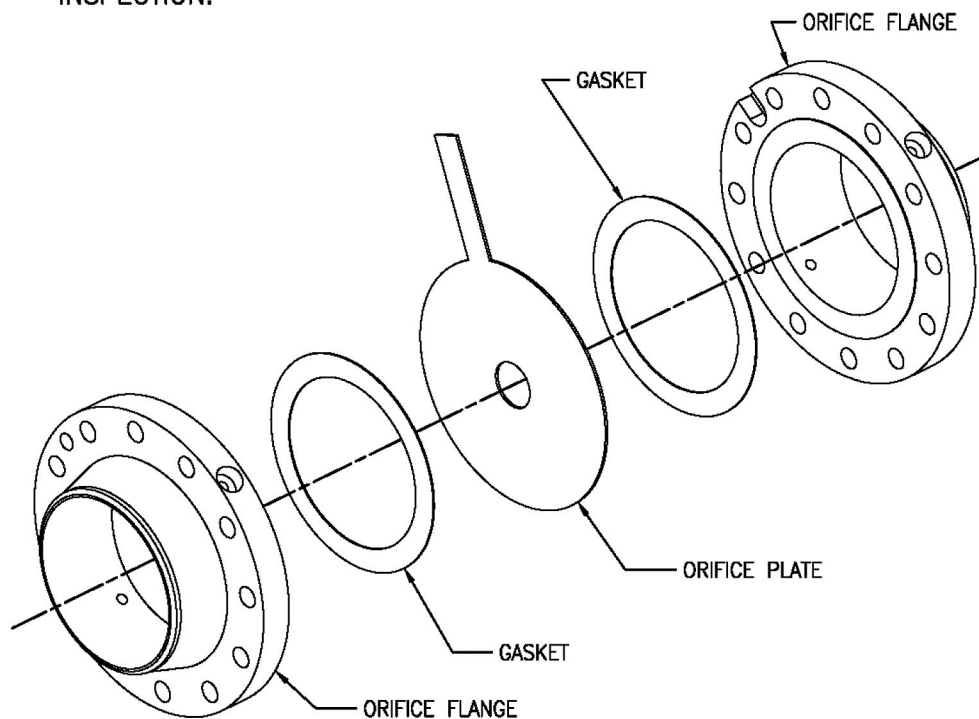

WHEN INSTALLING ORIFICE PLATE:

- 1.) ORIFICE BORE MUST BE CENTERED WITHIN 3% OF INSIDE PIPE DIAMETER.
- 2.) IF BORE IS BEVELED, BEVEL MUST FACE DOWNSTREAM.
- 3.) PIPE ENDS SHOULD BE FLUSH WITHIN 1/4" OF ORIFICE PLATE.
- 4.) INSIDE DIAMETER OF GASKETS MUST NOT PROTRUDE BEYOND INSIDE SURFACE OF PIPE,
- 5.) ORIFICE PLATE MUST BE INSTALLED FLAT WITHOUT DISTORTION.
- 6.) TIGHTEN FLANGE BOLTS EVENLY TO PREVENT PLATE BUCKLING.
- 7.) ON ORIFICE FLANGES OTHER THAN WELD NECK OR CORNER TAP, PRESSURE TAP HOLES MUST BE DRILLED THROUGH THE PIPE. HOLES MUST BE FREE OF BURRS OR OTHER IRREGULARITIES.
- 8.) GAS FLOW TAPS AND LIQUID FLOW TAPS SHOULD BE HORIZONTAL (ON SIDES).

Preventive Maintenance

1. Check Flange and Pressure Tap Connections for Leaks	Annually	By Instrumentation Operator or Mechanical Personnel
2. Inspect Exterior Finish for Scrapes, Dings, or Blistering	Annually	By Instrumentation Operator or Mechanical Personnel

- No special tools or skills are necessary for preventive maintenance tasking.
- No preventive maintenance parts list applicable.

Corrective Maintenance

In case of loss-of-signal or erratic output, check taps and impulse piping to secondary instrumentation for blockage or debris. Check impulse piping for leaks, trapped condensation (in the case of compressible gas flow), or trapped air (in the case of liquid flow.) In case of blockage, purge lines with air or water (as is appropriate) pressurized to approximately 30 PSI above line pressure.

WARNING: IN NO CASE SHOULD FLUSHING PRESSURE EXCEED THE DESIGN PRESSURE OF THE PROCESS OR IMPULSE PIPING.

In case of trapped condensate or trapped air, remove by use of bleed valves or plugs, or through the manifold at the flow transmitter.

Stop leaks by tightening, resealing, or re-gasketing as necessary.

Touch-up exterior finish with the same or a compatible coating system as necessary.

There are no test points, adjustments, or user-serviceable parts in the orifice plate, nor is there any assembly or disassembly. If the problems persist, contact Armstrong.

- Corrective maintenance can be performed by mechanical or plant personnel.
- No special tools are required for corrective maintenance.

Spare Parts

The orifice plate/s provided were designed and manufactured specifically for this project. The orifice plate has no moving or parts.

There is no parts list and there is no recommended stocking level.

Storage Requirements – Orifice Plates

Indoor Storage:

- The orifice plates can be stored indefinitely indoors in a clean, non-corrosive environment. If environment is not clean, meters must be covered.
- Orifice plates should be stored away from high traffic areas in order to minimize damage risk.
- If storage is to be long-term, it is recommended that meters be covered with a tarp or heavy plastic sheeting.

Outdoor Storage – Short Term (less than 3 months):

- Meters should be stored away from high traffic areas in order to minimize damage risk.
- It is recommended that the meters be covered with a tarp or heavy plastic sheeting.

Long Term Storage:

- Long-term storage requires indoor storage where temperature and humidity fluctuations are minimized. Otherwise, contact Armstrong.

VERIS, Inc.

Limited Warranty and Remedy

Veris, Inc. (“Veris”) warrants to the original user of those products supplied by it and used in the service and in the manner for which they are intended shall be free from defects in material and workmanship for a period of five (5) years from the date of installation, but not longer than 63 months from the date of shipment from the Veris factory, unless a Special Warranty Period applies, as noted below. This warranty does not extend to any product that has been subject to misuse, neglect or alteration after shipment from the Veris factory. Except as may be expressly provided in a written agreement between Veris and the user, which is signed by both parties, Veris **DOES NOT MAKE ANY OTHER REPRESENTATIONS OR WARRANTIES, EXPRESS OR IMPLIED, INCLUDING, BUT NOT LIMITED TO, ANY IMPLIED WARRANTY OF MERCHANTABILITY OR ANY IMPLIED WARRANTY OF FITNESS FOR A PARTICULAR PURPOSE.**

The sole and exclusive remedy with respect to the above limited warranty or with respect to any other claim relating to the products or to defects or any condition or use of the products supplied by Veris, however caused, and whether such claim is based upon warranty, contract, negligence, strict liability, or any other basis or theory, is limited to Veris’ repair or replacement of the part or product, or, at Veris’ option, to repayment of the purchase price. In addition to replacing any part of parts found to Veris’ satisfaction to be defective, Veris will pay the cost of shipment of both the defective part to the Veris plant and the replacement part to the original user. As a condition of enforcing any rights or remedies relating to Veris products, notice of any warranty or other claim relating to the products must be given in writing to Veris: (i) within 30 days of last day of the applicable warranty period, or (ii) within 30 days of the date of the manifestation of the condition or occurrence giving rise to the claim, whichever is earlier. **IN NO EVENT SHALL VERIS BE LIABLE FOR SPECIAL, DIRECT, INDIRECT, INCIDENTAL OR CONSEQUENTIAL DAMAGES, INCLUDING, BUT NOT LIMITED TO, LOSS OF USE OR PROFITS OR INTERRUPTION OF BUSINESS.** The Limited Warranty and Remedy terms herein apply notwithstanding any contrary terms in any purchase order or form submitted or issued by any user, purchaser, or third party and all such contrary terms shall be deemed rejected by Veris.

Special Warranty Periods are as follows:

Vortex Shedders, Venturi, Orifice Plates, Flow Nozzles and Wedge Meters: one (1) year from the date of installation, but not longer than 15 months from the date of shipment from the Veris factory.

Electromagnetic Flow and BTU Meters, Ultrasonic Flow and BTU Meters: 21 months from the date of installation, but not longer than 24 months from the date of shipment from the Veris Factory.

Electronic components, including without limitation, differential pressure transmitters, multivariable transmitters, flow computers, rate or totalizer displays: one (1) year from the date of installation, but not longer than 15 months from the date of shipment from the Veris factory.

Designs, materials, weights and performance ratings are approximate and subject to change without notice.
Visit armstronginternational.com for up-to-date information.



Armstrong International - VERIS Flow Measurement Group
5820 Glacier Way, Frederick, CO 80205 - USA Phone: 303-652-8550 Fax: 303-652-8552
armstronginternational.com