



Installation, Operation & Maintenance

FPC & FPS Series Electric Condensate Pumps

Caution: This unit is designed for atmosphere operation.
DO NOT PRESSURIZE RECEIVER.

SITE INSPECTION

The unit should be of the proper size and capacity for the proposed installation. Refer to the nameplate for rated capacities. Check motor and control voltages with the available power supply. (Units are normally factory wired for 115/1/60).

UNIT LOCATION

FPC & FPS units are designed with O.D.P. (Open Drip Proof) motors and NEMA 1 controls. Place unit only in areas of the proper classification. The unit should be located to allow for removal of pumps for replacement of seals.

VENT CONNECTION

Install a full sized vent to atmosphere from the receiver. **Do Not** install any shut off valves or other type valves in the vent line.

OVERFLOW

Install overflow piping to drain. (An overflow loop and anti siphoning orifice can be installed to prevent venting through the overflow).

RETURN PIPING

Properly pitched gravity return lines are piped to the unit as shown in the Typical Piping Diagram (Figure 1). An isolation valve should be installed for servicing. An inlet strainer should be installed to remove foreign materials and prolong the pump life.



FPC & FPS Series Electric Condensate Pumps

DISCHARGE PIPING

The correct discharge piping for the FPC & FPS Series pumps is critical for proper operation. Install a union immediately at the pump discharge. A non-slam type check valve should be installed after the union, close to the pump to prevent back flow into the unit. An isolation valve (gate valve) and a pressure gauge (gauge not shown below) need to be installed. A throttling valve (globe valve, ball valve or steam cock) is installed in the discharge pipe to set the pump discharge at the designed conditions. See Figure 1.

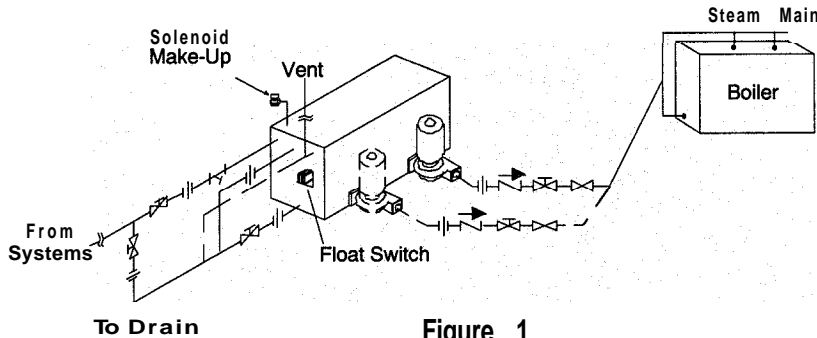

Figure 1

ELECTRICAL WIRING

FPC & FPS units are **single phase only**. Check supply current to make sure it matches motor name plate rating. (Units are usually wired for 115/1/60). Wire in accordance with the National Electric Code and all local electrical codes. See Typical wiring diagrams (Figures 2 and 3).

Double Pole Single Phase

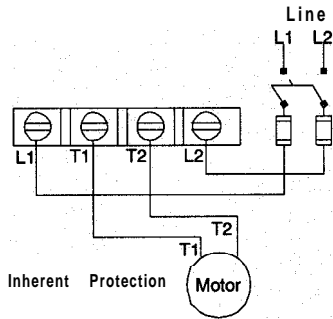

Figure 2 Float Switch

Single Phase Motor Control

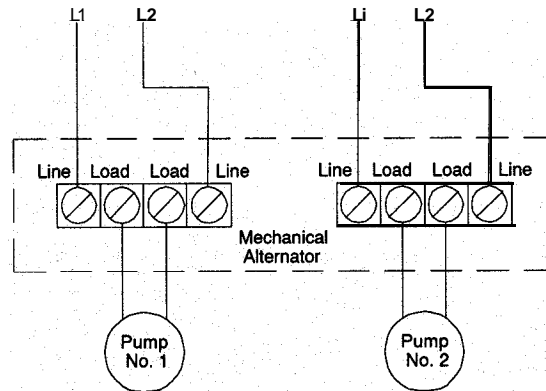

Figure 3 Mechanical Alternator

PLACING THE PUMPS IN SERVICE

Flush unit to drain to remove any debris from the receiver. Reinstall drain plug.

- A. Remove shipping bracket from each float switch or mechanical alternator as per manufacturer's instructions. (See instruction tag attached to switch).



FPC & FPS Series Electric Condensate Pumps

Mechanical Seal Replacement Instructions for FPC & FPS Series Pumps

- B. Prime the unit by filling the receiver approximately one-half (1/2) full of water. **(Do Not Run Pumps Dry)** Mechanical seals will be damaged by running pumps **dry. (Do Not Pressurize Receiver).** Receiver has been hydrostatically tested at the factory. Unit is designed for atmospheric operation only. **Do Not Restrict Vent.**
- C. Adjust the throttling valve (closed) installed in pump discharge to bring pump discharge pressure to design conditions, When proper conditions have been met, tighten valve and remove handle.
- D. The float switch has been factory set for maximum capacity of the receiver. Should an alternate setting be required, refer to the float switch manufacturer's instructions.
- E. **Lubrication:** The pump is close coupled centrifugal unit. The pump has no internal bearings. The motor should be lubricated as recommended by the motor manufacturer.

Make sure total system (i.e. pipe, radiators, receivers, etc.) is free from debris by blowing down to drain before start-up. Make sure all debris has been removed from the inlet strainer after start up of system. Should pump sound noisy, it may not be operating at design conditions. Adjust throttling valve to operate at the proper discharge pressure.

Note: Seals will be damaged if operated dry.

When it is necessary to replace a mechanical seal refer to the following procedures:

- A. Close the isolation valves on the return line to the unit and discharge lines.
- B. Disconnect power to motor, disconnect power wiring and conduit from motor.
- C. Loosen the bolts clamping the pump head between the pump case and motor. (With the suction flange bolted to the receiver, the long bolts can just drop to the floor).
- D. Separate the pump head from the case and lift the motor, pump head and the impeller out of the pump case.
- E. Holding the top end of the motor shaft with a screw driver or screw driver socket, turn the impeller counter clockwise by inserting a flat tool between the vanes of the impeller.
- F. Remove the rotating portion of the mechanical seal from the end of the motor shaft.
- G. Remove the pump head.
- H. Remove the ceramic or stationary portion of the mechanical seal and cup rubber from the pump head.



FPC & FPS Series Electric Condensate Pumps

- I. Install a new seal by thoroughly cleaning the machined recess in the pump head. Apply a thin coating of liquid detergent (**do not use grease**) to the recess and outer edge of the new cup rubber. The new ceramic seal can be pressed firmly into place **by hand**. Make sure the seal bottoms evenly. Should you be unable to bottom seal evenly, place a cardboard over the ceramic seal and force into place with a flat tool.
- J. With the motor in a vertical position (pump end up), install the pump head over the shaft.
- K. Clean the mating surfaces of the seal with a lint-free cloth. The carbon or rotating part should not be loose. Hold in place with a small amount of liquid detergent if necessary. Apply a small amount of liquid detergent (**do not use grease**) to the rubber and install over the shaft with the carbon contacting the ceramic seal.
- L. Place the impeller on the shaft and tighten (clockwise rotation).
- M. Reassemble by reversing procedures. Install a new head gasket between pump head and case.
- N. Reconnect power supply, open isolation valves, fill receiver one-half (1/2) full of water, pump is now ready for operation.

Do Not Run Pump Dry

- O. Pump may be tested by hand operating the float switch. Slight leakage may occur until seal surfaces adjust.

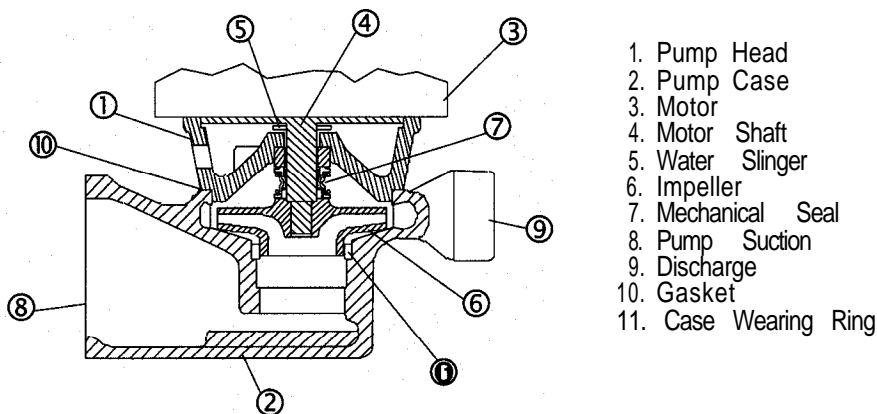

Figure 4



Armstrong Fluid Handling, Inc.

221 Armstrong Blvd, Three Rivers, Michigan 49093 • USA Phone: (616) 278-6500 / Fax: (616) 279-3150