

**Emech<sup>®</sup>**  
**Steam Water Mixing Valve**  
**Model F2**  
**Installation, Operation & Maintenance**  
**Manual**

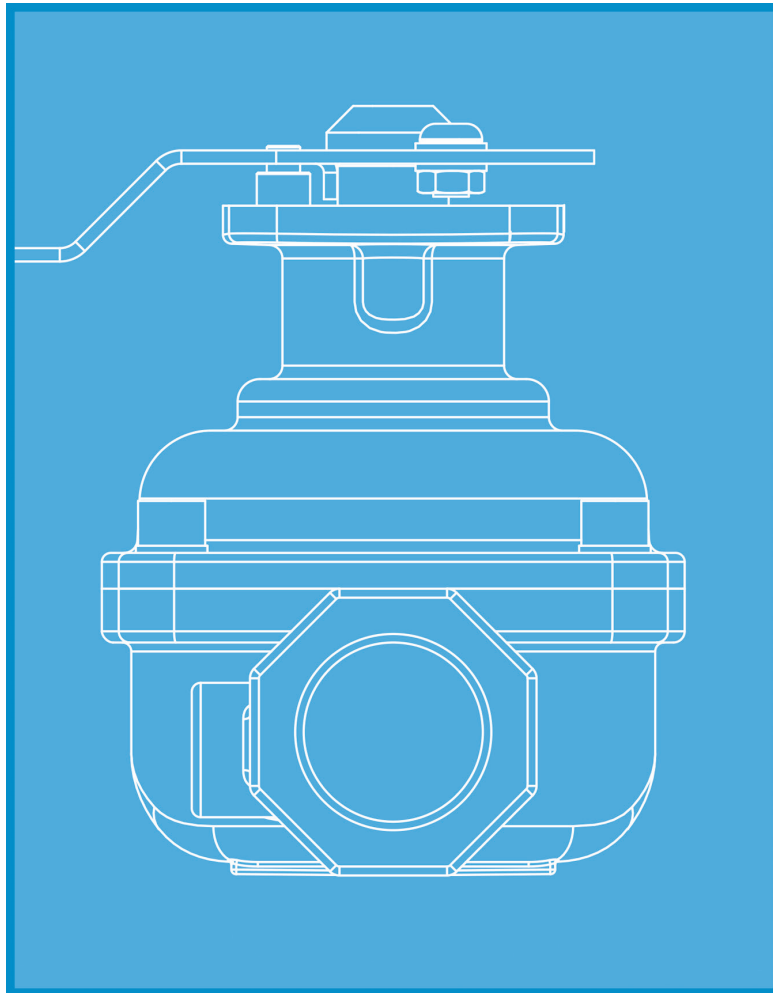

**Please read and save  
these instructions**



Section / Description	Page
FLOW CONTROL VALVE - MODEL F2 - INTRODUCTION.....	3
1.0 FLOW CONTROL - MODEL F2 - DATASHEET.....	4
Parts and Materials.....	5-6
Dimensions.....	7
Specifications.....	8
Operating Torque.....	9
Performance.....	10
2.0 INSTALLATION.....	11
3.0 MAINTENANCE - DISASSEMBLY.....	12
4.0 MAINTENANCE - REASSEMBLY.....	13, 14, 15
5.0 EMECH VALVE to G1 ACTUATOR MOUNTING INSTRUCTIONS.....	16
IMPORTANT NOTICE.....	17
LEGAL DISCLAIMER.....	18
NOTES.....	19

## Introduction

Congratulations on selecting the Emech™ product from Armstrong. Armstrong devotes considerable care and attention to the design of its products. To obtain the best performance from them, the customer should read this manual from cover to cover. It contains important installation and operating instructions.

The customer must strictly adhere to the safety tips, trouble shooting advice, cautions and warnings appearing throughout this manual. Along with the warnings, instructions and procedures in this manual, the customer should also observe such other procedures generally applicable to equipment of the same type.

If the customer does not follow these and other such warnings, instructions and procedures, the product may not perform as expected. More seriously, it may cause property damage, personal injury, production down-time and other losses.

The customer should train its employees and contractors in the safe use of Armstrong products in relation to the customer's specific application. If the customer does not understand a point in this manual, contact Armstrong or its authorized representative.

## F2 Valve General Features

The Emech 2 port valve utilizes ceramic shear action disc technology to provide tight shut-off, high pressure differential capability and long life integrity.

Combined with the Emech digital actuator, high speed stand alone closed loop control is possible. The Emech 2 port valve utilizes ceramic shear actions discs as the dynamic seal.

The extremely hard nature of the ceramic produces outstanding resistance to wear and cavitation damage compared with conventional elastomer and plastic seated valves, minimizing seal replacement and plant downtime.

### Valve Features

- 1/4 Turn Action
- ISO 5211, 5210 actuator flange mounting
- Constructed of 316 (CF8M) stainless steel
- Ceramic discs - durable, corrosion resistant
- End connections: NPT, ASME Cl. 150 Flanges, Socket Weld, Sanitary Styled Flanges
- Elastomer seal options
- Top entry allows inline access to internal valve parts
- Size range: 3/4" (20 mm), 1" (25 mm), 1 1/2" (40 mm) and 2" (50 mm)
- Body temperature range: -13°F to 257°F (-25°C to 125°C)
- Rated pressure: 145 psi
- Maximum dynamic pressure drop of 130 psi
- BUBBLE TIGHT (zero leakage) shut-off\*
- Manual handle option lock-able in both open and closed position
- Liquid and gas capable

Handle can be padlocked in the open or closed position, and can be 'stroke limited'

Graduated scale on the handle



Low torque 90° stroke operation

### Digital Control

The Emech 2 port valve can be fitted with the Emech digital actuator to provide modulating control. Closed loop control can be achieved by connection of appropriate sensors to the actuator e.g. temperature, flow, or pressure transducers.

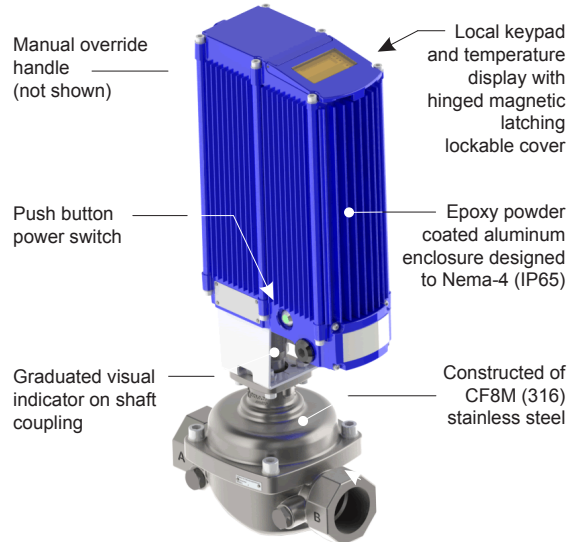

### F2050 with G1 Digital Actuator

#### Features of the Emech G1 Digital Actuator

- Analogue (4-20mA) and digital (Rs232) communication
- Speed, position, and acceleration control
- User defined '2-speed' stroke can eliminate water hammer
- Very high resolution capability (0.03° rotational)
- Local closed loop control of Temperature
- External RS232 connection (cable supplied) for actuator configuration
- Local / Remote control options
- Failsafe position feedback (non-contact absolute encoder)
- 4 membrane switches with 'dual touch' safety feature
- 3.5 digit LCD display with back light display
- Push button power switch

(See separate document for details about the Emech G1 Digital Actuator.)

**Note:** \* Seat seal performs beyond the requirements of ANSI B16.104 and FCI 70-2, Classes V and VI.

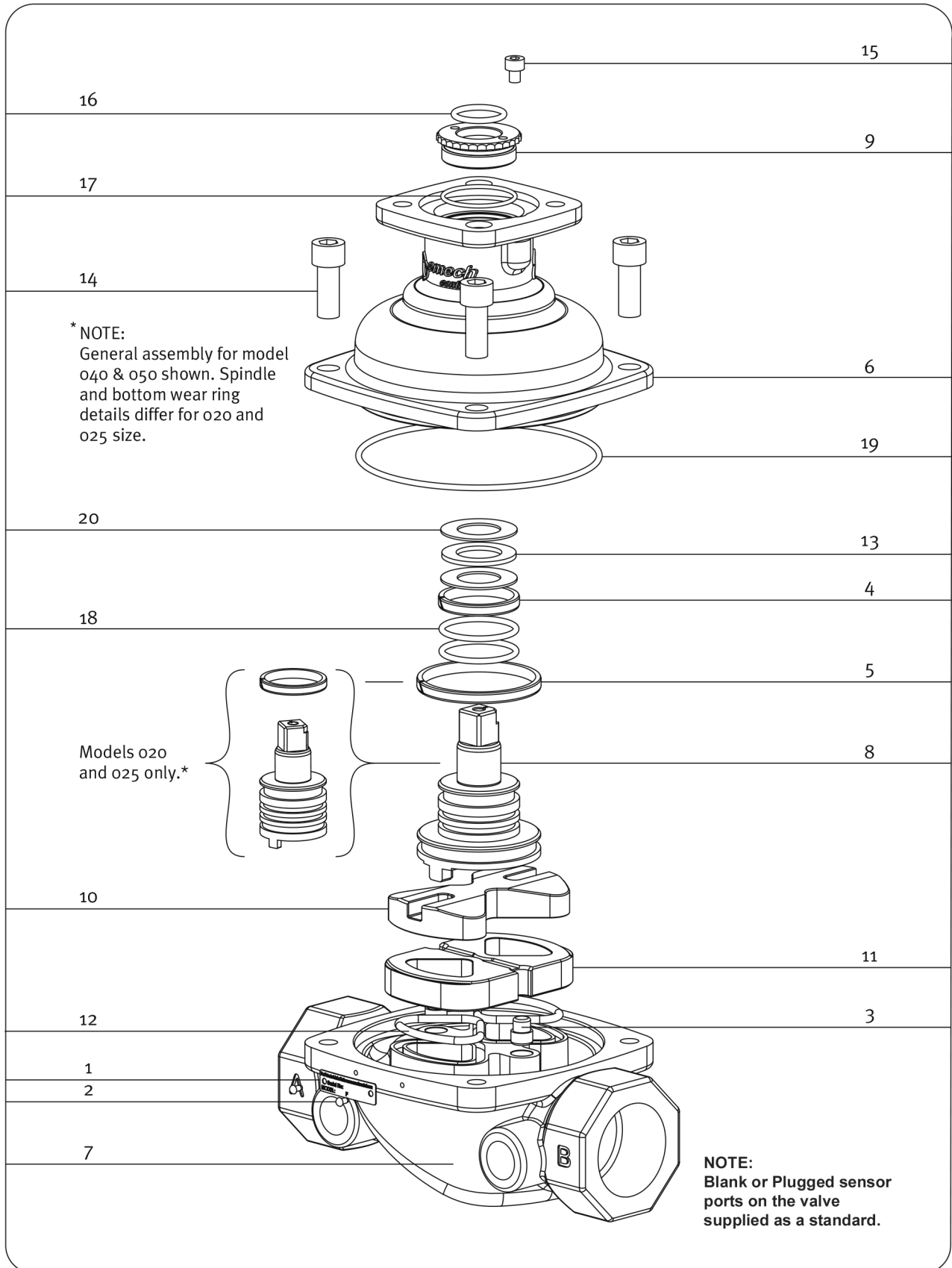



# Flow Control Valve-Model F2 Parts and Materials

Part	Description	Quantity	Material	Code:			
				F2020	F2025	F2040	F2050
				Inlet Size: 3/4" (20 mm) 1" (25 mm) 1-1/2" (40 mm) 2" (50mm)			
1	Name Plate	1	316 stainless steel				
2	U Hammer Drive Screw	2	316 stainless steel				
3	Pin	2	316 stainless steel				
4	Top Wear Ring	1	trim dependent	1)	1)	1)	1)
5	Bottom Wear Ring	1	trim dependent	1)	1)	1)	1)
6	Bonnet	1	CF8M (316) stainless steel				
7	Body	1	CF8M (316) stainless steel				
8	Spindle	1	316 stainless steel				
9	Gland Nut	1	316 stainless steel				
10	Top Disc	1	trim dependent	2)	2)	2)	2)
11	Bottom Disc	1	trim dependent	2)	2)	2)	2)
12	Energizers O-ring	2	trim dependent	1)	1)	1)	1)
13	Needle Roller Bearing	1	C-Cr steel	1)	1)	1)	1)
14	Screw Body/Bonnet	4	304 stainless steel				
15	Screw Locking (M4 x 6)	1	304 stainless steel				
16	O-Ring Gland Internal	1	trim dependent	1)	1)	1)	1)
17	O-Ring Gland External	1	trim dependent	1)	1)	1)	1)
18	O-Ring Spindle	2	trim dependent	1)	1)	1)	1)
19	O-Ring Body/Bonnet	1	trim dependent	1)	1)	1)	1)
20	Thrust Washer	2	C-Cr steel	1)	1)	1)	1)

Spare Kits:		F2020	F2025	F2040	F2050
1) Included in Valve Trim	F2 - Seal Kits	CPSK0001	CPSK0002	CPSK0017	CPSK0018
2) Included in Valve Trim	F2 - Ceramic Disc Sets	CPSK0005	CPSK0006	CPSK0007	CPSK0008
3) Locating Pins		CPME0059	CPME0059	CPME0081	CPME0088

### Emech F2 - Actuation Options:

	F2 Valve Size	Recommended Emech Actuator Model
Electric Actuators	020, 025 and 040	G12
	050	G13
Handle Kits	020 and 025	CPSK0013
	040 and 050	CPSK0014

#### Trim selection

The following table is Armstrong's recommendation for trim selection.

Compound	Maximum recommended fluid temperature in Emech valves	Application	Compound Compatibility recommendations
EPDM	-13 to +257°F	All water and Glycol applications.	Water, steam, hydroxides, solvents, alcohols, several acids, ketone & silicone oils.

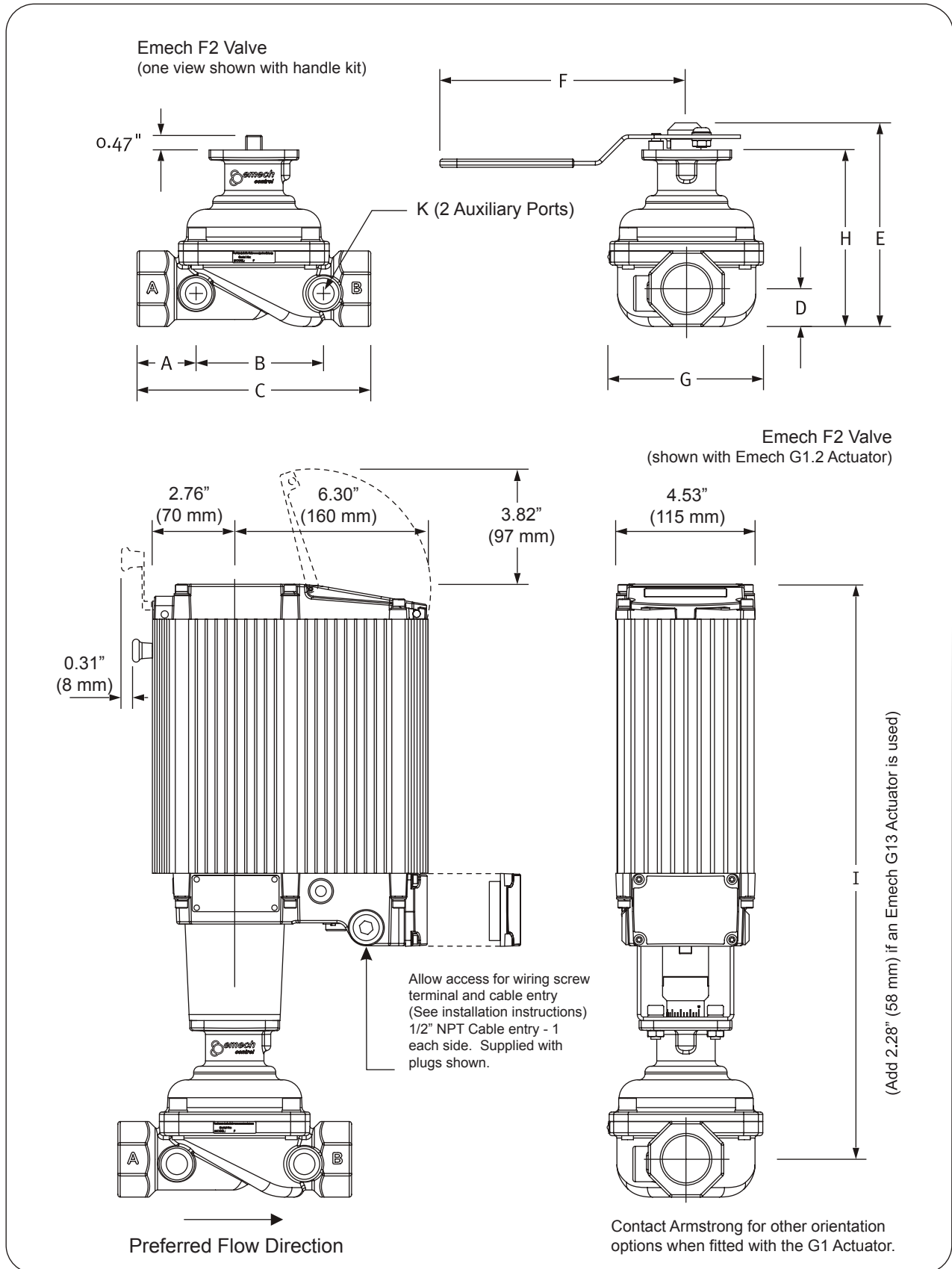



# Flow Control Valve - Model F2 Specifications

Nominal Valve Size <sup>(1)</sup>		3/4" (20 mm)	1" (25 mm)	1 1/2" (40 mm)	2" (50 mm)
	NPT	0.75"	1.00"	1.50"	2.00"
	A	1.30" (33 mm)	1.38" (35 mm)	2.00" (50 mm)	2.32" (59 mm)
	B	2.50" (64 mm)	3.35" (85 mm)	4.25" (108 mm)	5.50" (140 mm)
	C	2.72" (120 mm)	5.85" (149 mm)	7.85" (199 mm)	9.84" (250 mm)
	D	0.71" (18 mm)	0.87" (22 mm)	1.26" (32 mm)	1.54" (39 mm)
	E	4.92" (125 mm)	5.35" (136 mm)	6.81" (173 mm)	7.64" (194 mm)
	F	6.58" (167 mm)	6.58" (167 mm)	8.07" (205 mm)	8.07" (205 mm)
	G	3.03" (77 mm)	3.90" (99 mm)	5.12" (130 mm)	6.42" (163 mm)
	H	4.02" (102 mm)	4.49" (114 mm)	5.87" (149 mm)	6.77" (172 mm)
	I	17.52" (445 mm)	17.95" (456 mm)	18.90" (480 mm)	19.57" (497 mm)
Auxiliary Port Thread Size:	K	0.25"	0.25"	0.50"	0.50"
Operational Stroke °rotational	with Handle kit	90	90	90	90
<b>Flow characteristics (90° open, 100% open Cv (Kv))</b>					
Cv (Kv): USgpm at dP=1 psi, 68°F (m3/h at dP=1 bar, 20°C)		16.2 (14.1)	27.9 (24.3)	48.9 (42.5)	82.8 (72)
Flow @ 29psi dP	U.S.Gpm (lpm)	88 (332)	150 (573)	264 (1002)	449 (1697)

### Leakage Characteristics

The F2 Emech ceramic shear action valves have bubble tight (zero leakage) shut-off. The Emech seat seal performs beyond the requirements of ANSI B16.104 and FCI 70-2 Classes V and VI.

### Body Pressure Rating - Designed to ASME B16.34

Operating Pressure @ <257°F (125°C) psi (bar)	145 (10)	145 (10)	145 (10)	145 (10)
---	----------	----------	----------	----------

### Physical Characteristics Weight (approx)

Valve only	lb (kg)	3.0 (1.5)	5.0 (2.5)	12.0 (5.5)	21.0 (9.5)
Valve and Emech G12 Actuator	lb (kg)	220 (10.0)	24.5 (11.0)	31.0 (14.0)	50.0 (23.0)

### Valve Topworks Dimensions For Actuator Mounting (Spigot/bolts as per ISO 5210/ISO 5211)

Shaft/Stem Connection	sw.std (mm)	0.39" (10)	0.39" (10)	0.55" (14)	0.55" (14)
Topworks 4 holes	PCD (mm)	1.97" (50)	1.97" (50)	2.76" (70)	2.76" (70)
Topworks, PCD hole Ø	inch (mm)	0.26" (6.5)	0.26" (6.5)	0.33" (8.5)	0.33" (8.5)
Topworks, Spigot diameter	inch (mm)	1.38" (35.1)	1.38" (35.1)	2.17" (55.1)	2.17" (55.1)
Valve mounting restrictions		None	None	None	None

### Notes:

(1) Note G12 actuator is recommended for 3/4" (20 mm), 1" (25 mm), and 1 1/2" (40 mm) F2 sizes. The G1.3 is recommended for the F2 size 2" (50 mm) valve.

- All specifications are for water.
- Flows are quoted without terminal fittings, restrictors, or non-return valves on the inlets. (Non-return valves are recommended.)
- If operating at more than one maximum rated condition, contact Armstrong to confirm the application is appropriate.

### Definitions:

dP max.	Maximum allowable valve closed differential pressure across the valve from inlet to outlet.
Operating Pressure	Valve body pressure rating.





# Flow Control Valve - Model F2 Operating Torque

## F2 Break Open Torques

Break Open Torque (lb.in)		
Valve Size	Shut off Pressure (psi)	
	0	145
020 F2	17	31
025 F2	27	40
040 F2	89	185
050 F2	124	230

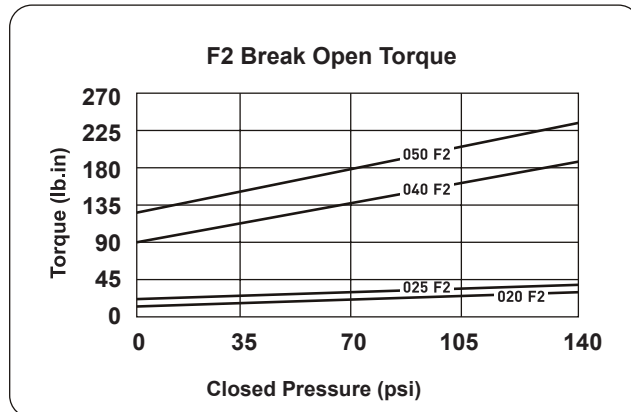

### Note:

1. The charted seating and unseating torques are the sum of all friction and resistance for opening and closing of the disc against the indicated pressure differential for normal service.
2. The relationship between values are linear, and can therefore be interpolated between nominated values.
3. The effect of dynamic torque is not considered in the table.
4. In sizing operators it is not necessary to include safety factors.
5. Break-open torques are approximately equal to the shut-off torques.

The charted values are based on clean liquid service at temperatures between 32°F to 212°F with no internal deposition or chemical attack, operated a minimum of once a day.\*

For conditions that vary from those noted above, apply the following application factors.

### \*Frequency of operation

- < once per day +15%
- < once per week +25%
- < once per month +40%
- < once per year +80%

### Service conditions

- Dry service +30%
- Light slurry semi-solids +40%
- Heavy slurry and some solids +70%
- Temperature: -13°F to 14°F +30%
- 14°F to 32°F +15%
- Over 212°F to 257°F +30%

**Note:** The above factors are cumulative but never more than 2x the value shown in the Break Open Torque tables above.

### Emech F2-Standard Model Codes:

Model Code	Description	End Connection	Flow Control Unit Codes
F2020	F2 VALVE 3/4" (20mm) NPT	Screwed NPT	E20F
F2025	F2 VALVE 1" (25mm) NPT	Screwed NPT	E25F
F2040	F2 VALVE 1-1/2" (40mm) NPT	Screwed NPT	E40F
F2050	F2 VALVE 2" (50mm) NPT	Screwed NPT	E50F

### Emech F2- Model Codes on request:

Model Code	Description	End Connection	Flow Control Unit Codes
D48916	F2 Valve 1"(25mm) SW	Socket Weld ASME B16.34	
F2040R	F2 VALVE 1-1/2"(40mm) FLG	Flanged ASME CL.150	E40FR
F2050R	F2 VALVE 2"(50mm) FLG	Flanged ASME CL.150	E50FR
F2050RH	F2 VALVE 2"(50mm)SANITARY FLG	Flanged ASME CL.150	

The Flow Control Units includes Valve, Actuator, Mounting Kit, Serial Cable, Temperature Sensor, Spanner and all relevant IOM's.

## F2 Valve Performance

Representation of typical flow characteristic of the F2 valve through 90° of rotation.

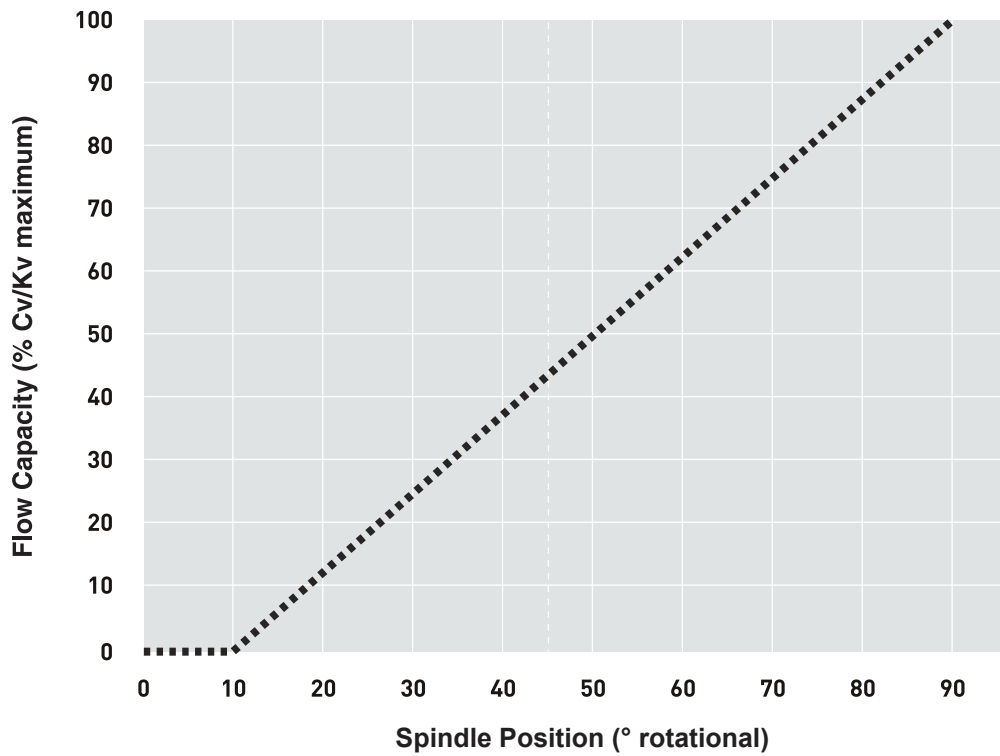
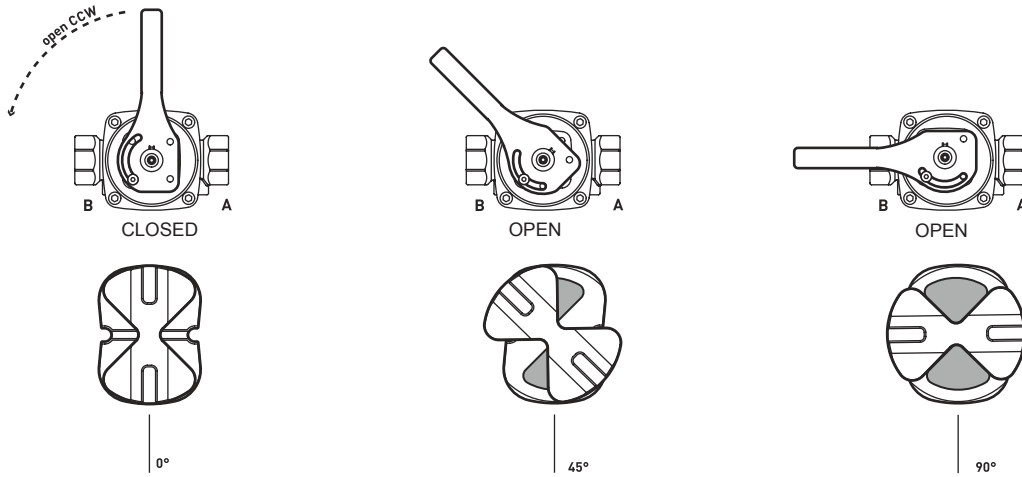

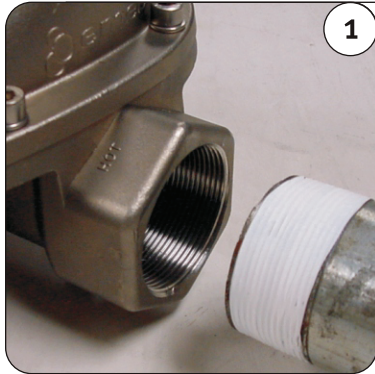

1

When installing the valve in line, be sure to follow good practice using either sealing tape or thread adhesive in the joints.

The valve may be attached straight to the pipework.

NOTE: Be sure to consider the ease of removing the valve should this become necessary in the future. See images 3 and 4 below for typical installation methods.

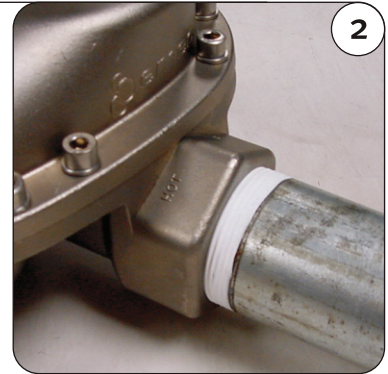

2



3

NOTE: For valve maintenance, the bonnet screws can be removed and full access to the internal components is possible.

The valve may be connected to the pipe work with a union style of fitting.

The valve may be connected to the pipe work with a thread adapter and a clamp style fitting, e.g. Tri-Clover™.

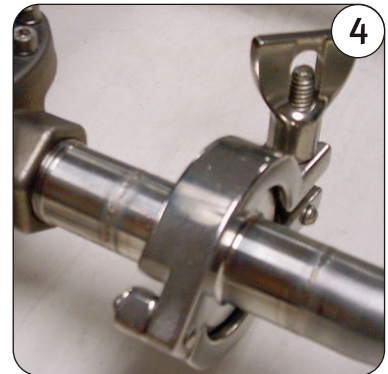

4

- CAUTION:** Prior to installation ensure that the pipes leading to the valve are clear from debris which may block or damage the valve on commissioning.
- WARNING:** Only trained personnel familiar with pipe work and pressure systems should install and maintain Emech equipment. Failure to do so may result in serious personal injury!
- WARNING:** Depressurize pipe work to atmospheric pressure and drain all fluids from the pipe work before working on the valve. Failure to do so may result in serious personal injury!
- WARNING:** Ensure that the intended maximum operating pressure of the line does not exceed the pressure rating of the valve. Failure to do so may result in serious personal injury!
- WARNING:** The valve must be supported adequately so as not over stress the pipe work and or the valve body. See Figure 5 and Table 2.1 below for the maximum nozzle loads on the valves. Application of loads above these values may result in serious personal injury and or equipment damage!

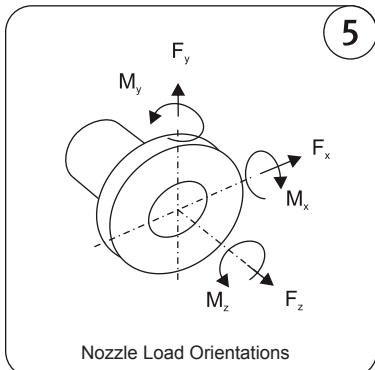

5

**TABLE 2.1: Maximum Nozzle Forces and Moments for Flanged and Screw end F2 valves**

VALVE SIZE	FORCE - $F_x, F_y, F_z$		MOMENT - $M_x, M_y, M_z$	
	SCREW	FLANGED	SCREW	FLANGED
020 F2	56 lbf. (250 N)	45 lbf. (200 N)	620 lbf.in (70 Nm)	496 lbf.in (55 Nm)
025 F2	90 lbf. (400 N)	72 lbf. (320 N)	1150 lbf.in (130 Nm)	920 lbf.in (105 Nm)
040 F2	180 lbf. (800 N)	144 lbf. (640 N)	1150 lbf.in (130 Nm)	2124 lbf.in (240 Nm)
050 F2	450 lbf. (2000 N)	360 lbf. (1600 N)	1150 lbf.in (130 Nm)	4248 lbf.in (480 Nm)

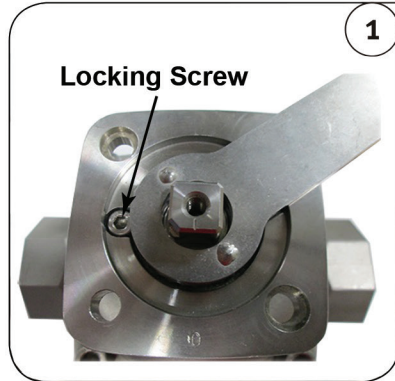

1

Locking Screw

**CAUTION!**  
Before dismantling the valve, ensure all upstream and downstream pressurised pipe work is isolated appropriately. Ensure the pressure and fluids are drained from the valve and pipe work. After removing the gland nut locking screw, unwind the gland nut counterclockwise using the spanner provided. (Image 1) Using a hex wrench, remove the four cap screws around the bonnet. (Image 2)

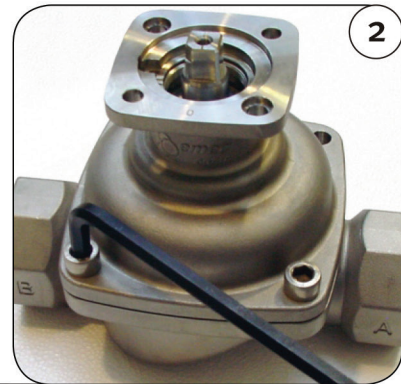

2

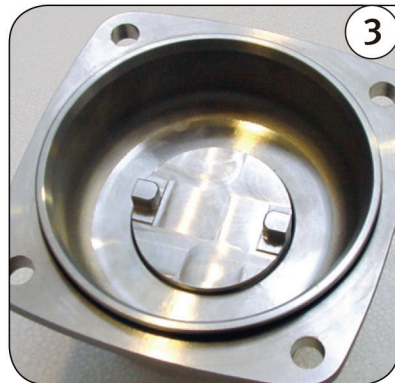

3

Carefully remove the bonnet from the body particularly if the valve is mounted in a vertical position. The spindle may detach from the rotating disc and remain in the bonnet. (Image 3). Remove the spindle and ensure that the two thrust washers and needle bearing is on the spindle. You may have to remove these from the bonnet. Alternately the spindle may stay attached to the rotating disc in which case it should be carefully removed. (Image 4)

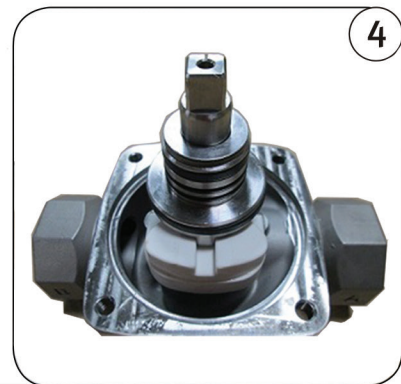

4



5

In either situation, the spindle will need to have two O-rings and two wear rings removed (Image 5).

Remove the discs from the valve body.

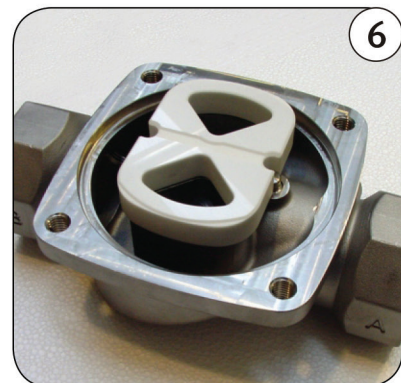

6

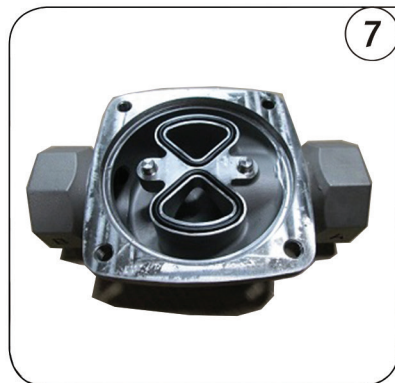

7

Remove two energizers and check the pins for any damage. If the pins are damaged they need to be ordered separately (Image 7).

Finally remove the O-ring around the flange of the bonnet (Image 8).

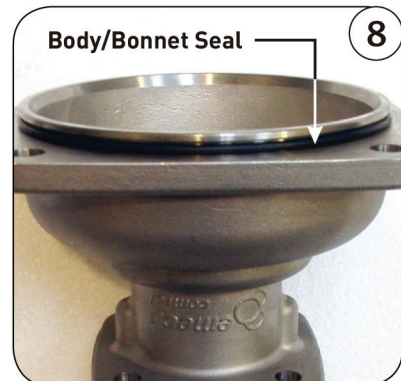

8

Body/Bonnet Seal

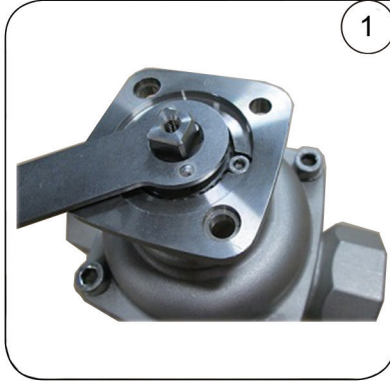

1

Replace the pins if they are damaged. Before assembling/re-assembling the valve, make sure hands are free of dirt and grease and the valve is clean.

Fit the energizers into the body. Apply a light even coat of grease to all seals. All Emech seal kits are provided with recommended lubricant. (See table 4.2 on page 15).



2

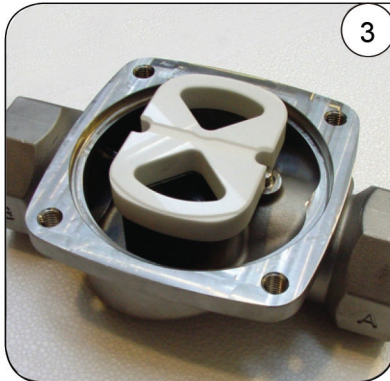

3

Place the bottom disc onto the valve body. Apply a light even coat of grease to the top surface of the bottom disc. (Image 3)

Place the top disc on the bottom disc and bed it down by rotating one on the other.

Ensuring the disc slots are clear of dust or dirt, check the spindle fits neatly into the slots on the top disc.

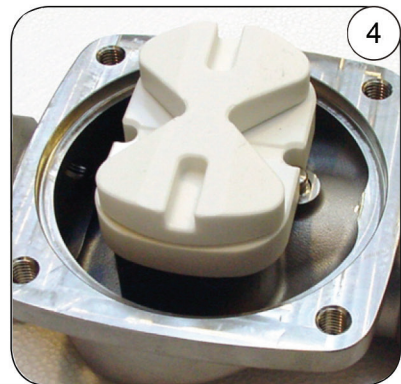

4

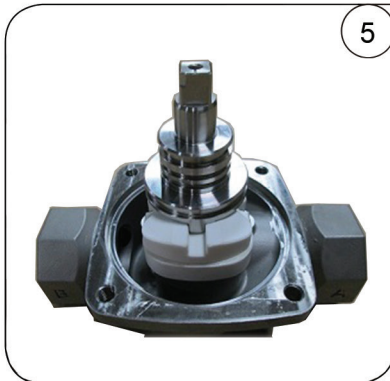

5

NOTE: The spindle should be tight fitting. If the spindle does not sit flat on top of the disc, clean lugs. If the spindle still does not sit flat, file the lugs.

Fit the two O-rings and the top and bottom wear rings to the spindle.

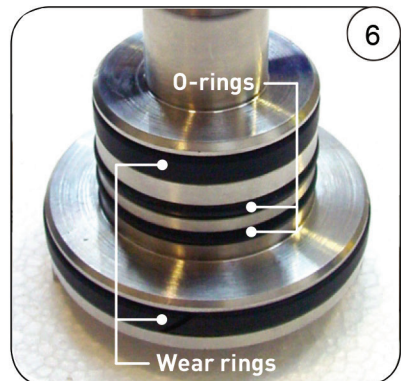

6

Continued....

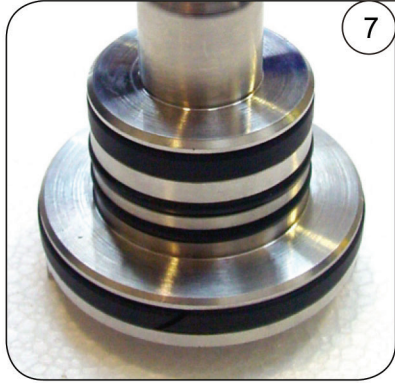

7

Apply a light even coat of grease to the spindle bearing surfaces and the O-rings (Image 7).

Check the fit of the spindle in the bonnet (Image 8). If the spindle fits, proceed to Image 9.

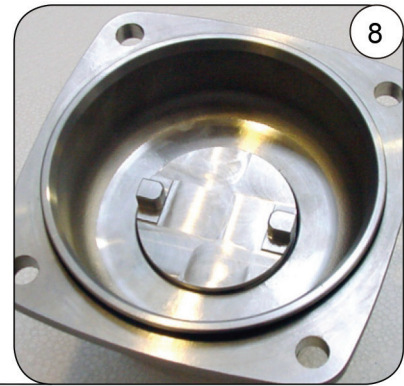

8

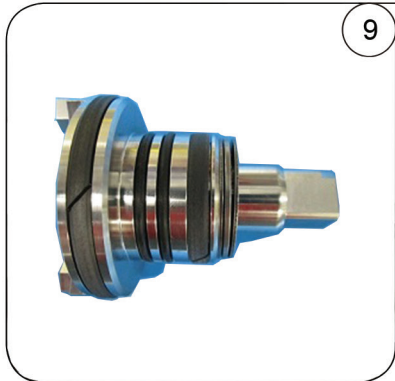

9

Lightly grease both sides of the thrust washer and place on the spindle. Place on the needle roller bearing (Image 9) and apply grease (approx 60% of the void space). Lightly grease both sides of the second thrust washer and place on the bearing.

Apply a light even coat of grease to the body/bonnet seal O-ring and bonnet bore. Place the O-ring around the perimeter of the bonnet (Image 1).

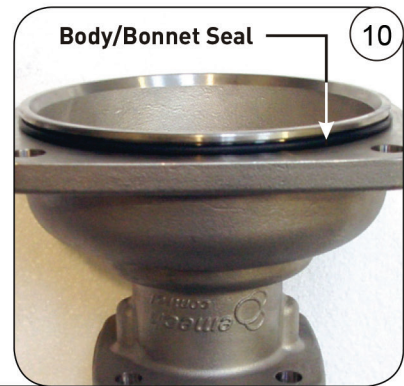

10

Body/Bonnet Seal



11

Align the discs with the spindle on top before gently lowering the bonnet over the spindle down to the body (Image 11).

Secure down the bonnet with the allen head cap screws using an allen wrench (Image 12).

Check the torque of the bolts to the range indicated in table 4.1. (See table 4.2 page 15).

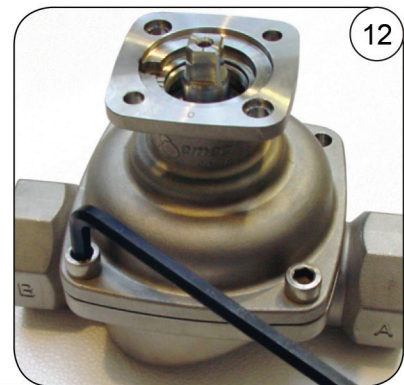

12

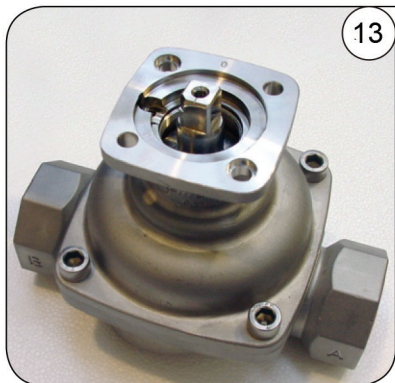

13

Rotate the spindle one full rotation. The movement should be smooth and even with no variation in torque (Image 13).

Lubricate inside and outside of the gland nut, paying particular attention to the thread. Insert the O-ring in the gland nut and then the external O-ring (Image 114).

continued.....

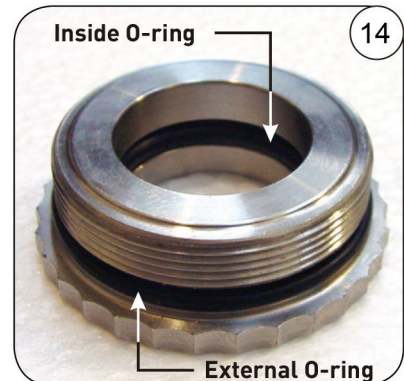

14

Inside O-ring

External O-ring



15 With the gland wench provided, screw the gland nut down until it bottoms out. Do not over-tighten! (Image 15).

Back the gland nut off 3 notches (70 degrees). If the notch does not align with the locking screw head, back the gland nut off further to align (Image 16).

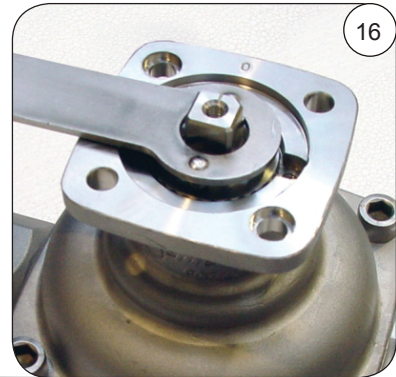

17 Insert the locking screw after applying a thread locking adhesive (Image 17). Tighten the locking screw as per the torque values given in table 4.1.

NOTE: Rotate the spindle 1-2 times to ensure the operating torque is constant, and the rotating action is smooth.

Reassemble and connect the handle kit or actuator to the valve. When connecting to an actuator, ensure that the valve and actuator are both in the "zero" or starting position before mounting together.

NOTE: The valve is CLOSED when the spindle notch points to the "0" mark stamped on the valve top (see Image 17).

**Table 4.1: Nominal Tightening Torques for Lubricated Stainless Steel Socket Head Cap**

Metric Cap Screw			UNC Cap Screw		
Size	Torque (Nm)	Torque (inlb)	Size	Torque (Nm)	Torque (inlb)
M3	1.3	12	#8-32	3.3	27
M4	2.9	26	#10-24	5.5	49
M5	5.7	50	1/4"	11	97
M6	10	89	5/16"	22	195
M8	25	221	3/8"	39	345
M10	47	416	1/2"	95	841
M12	82	726			

**Table 4.2: Recommended Lubricant**

Description	Manufacturer/Model Code	Used for:
Premium Food Grade PTFE Grease	mx6Inox	Ceramic discs; o-rings; wear rings; bonnet bore lubrication; roller thrust bearing lubricant All Stainless Steel Fasteners
*Sachets of this lubricant are included in the Seal Kits.		

## 1.0 Preparing the actuator for assembly onto Emech™ valves

Before fitting the actuator to the valve assembly, ensure the actuator is in the zero position. All new or replacement Emech actuators are shipped in the zero position. To check the actuator position or to re-zero an actuator follow section 1.1 if a power supply is available or section 1.2 for manual re-zeroing.

### 1.1 Automatically zeroing the actuator (24Vdc power supply required)

Power on the actuator (a 24Vdc regulated power supply is required). Refer Section 3 of the G1 actuator installation, operation and maintenance manual for electrical installation. With a temperature sensor connected to Port 1 of the actuator ensure the actuator is in Temperature Controller mode (hold mode and press down (-) on the actuator keypad to toggle between Positioner or Temperature mode). Now disconnect the temperature probe from the actuator. The actuator will move automatically to the 'zero' position and display "E2" on the keypad display.

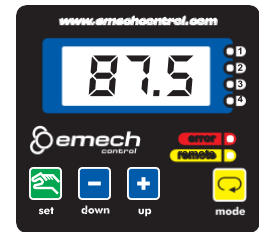

G1 actuator keypad

### 1.2 Manually zeroing the actuator

If there is no power available to 'zero' the actuator it is possible to use the actuator's manual override handle to adjust the actuator shaft position.

The actuator 'zero' is achieved when the coupling keyway is at 45° to the reference plane as indicated in images 1 and 2.

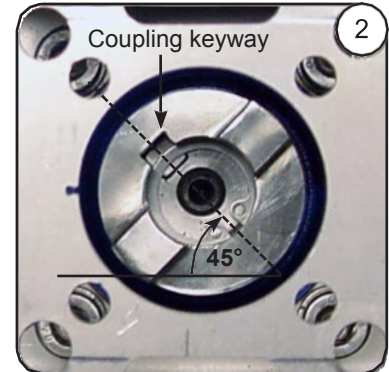
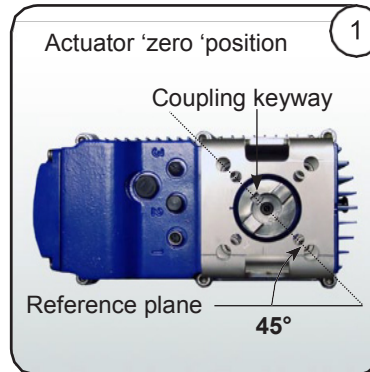

## 2.0 Actuator mounting orientation

To accommodate installation space restrictions the actuator may be mounted to an Emech valve in any one of four positions. The instructions provided in this document explain how to mount the actuator in the standard orientation for each type of Emech valve. To mount the actuator in one of the other three off-set orientations see figure 2.1. Follow the directions outlined in section 2.1.

### 2.1 Nonstandard mounting orientations

Ensure the valve is in the "0" position by following the standard mounting instructions for the valve in the relevant chapter of this document. When it comes to placing the graduated coupling onto the valve spindle orientate the coupling so the "0" mark aligns with the desired off set direction as indicated in figure 2.1.

Continue with the standard mounting instructions. Ensure the notch (zero indication on bracket) in the actuator bracket aligns with the coupling "0" when the actuator is fitted to the valve.

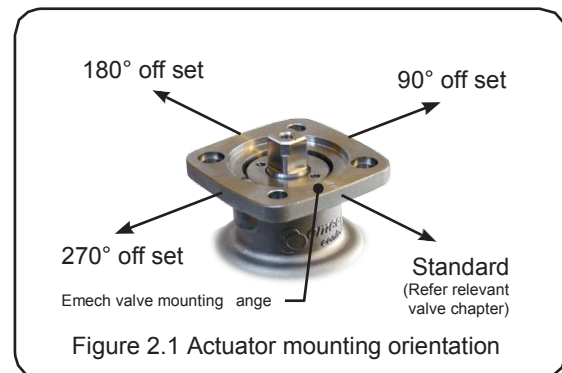

The valve and actuator will operate as per a standard mounting assembly





## Important Notice

Armstrong's products are capable of being used in many different types of industrial applications and operating environments. Consequently, Armstrong is only able to provide general guidelines concerning the suitability and use of its products. It is not possible for Armstrong to provide specific guidelines for specific applications and operating environments simply because there are too many of them. Therefore, proper selection of a specific product for a specific application and operating environment, and its compatibility with other equipment to which it is attached, is the customer's responsibility. The customer must assume the ultimate responsibility for the proper sizing, selection, compatibility, installation and operation of Armstrong products. All operating parameters should be validated for the customer's application by a professional engineer, qualified installer or by another technical expert. Armstrong does not warrant the performance of its products or their suitability for a particular purpose.

Although the information is believed to be accurate, Armstrong accepts no liability for any errors or omissions. Armstrong has endeavored to provide timely information but it cannot represent that the information is complete. The information shall not be deemed a warranty, representation or guarantee concerning a product's suitability or fitness for a customer's specific purpose. Armstrong does not warrant the information or any particular benefits that the customer will derive. It is the customer's responsibility to determine the suitability for its own use of the products described herein. The customer must make its own independent judgment and assessment and should not rely upon any opinions, interpretations, statements, assurances or representations given.

Because Armstrong is continually improving and upgrading its products, the specifications, dimensions and information contained herein are subject to change without notice. This information is intended to provide general guidance to the customer. For specific guidance or support, contact Armstrong or its authorized representative.

Installation is entirely at the customer's risk. Armstrong accepts no liability for direct, indirect, incidental, special, or consequential damages resulting from the customer's failure to follow Armstrong's warnings, instructions and procedures or such other procedures generally applicable to equipment of the same type. The foregoing limitation extends to damages to person or property as well as loss of profits, loss of products, loss of operations, the cost of alternative arrangements and loss of time, whether incurred by the customer, its employees or a third party.

Armstrong products should be installed by qualified technicians only. Do not attempt installation unless you are a qualified technician. Armstrong accepts no liability for damages resulting from faulty installation.

Nothing in this document is intended to cancel, modify or supersede the terms of the Armstrong Limited Warranty and Remedy.



## Limited Warranty and Remedy

Armstrong International, Inc. or the Armstrong division that sold the product (“Armstrong”) warrants to the original user of those products supplied by it and used in the service and in the manner for which they are intended, that such products shall be free from defects in material and workmanship for a period of one (1) year from the date of installation, but not longer than 15 months from the date of shipment from the factory, [unless a Special Warranty Period applies, as listed below]. This warranty does not extend to any product that has been subject to misuse, neglect or alteration after shipment from the Armstrong factory. Except as may be expressly provided in a written agreement between Armstrong and the user, which is signed by both parties, Armstrong **DOES NOT MAKE ANY OTHER REPRESENTATIONS OR WARRANTIES, EXPRESS OR IMPLIED, INCLUDING, BUT NOT LIMITED TO, ANY IMPLIED WARRANTY OF MERCHANTABILITY OR ANY IMPLIED WARRANTY OF FITNESS FOR A PARTICULAR PURPOSE.**

The sole and exclusive remedy with respect to the above limited warranty or with respect to any other claim relating to the products or to defects or any condition or use of the products supplied by Armstrong, however caused, and whether such claim is based upon warranty, contract, negligence, strict liability, or any other basis or theory, is limited to Armstrong’s repair or replacement of the part or product, excluding any labor or any other cost to remove or install said part or product, or at Armstrong’s option, to repayment of the purchase price. As a condition of enforcing any rights or remedies relating to Armstrong products, notice of any warranty or other claim relating to the products must be given in writing to Armstrong: (i) within 30 days of last day of the applicable warranty period, or (ii) within 30 days of the date of the manifestation of the condition or occurrence giving rise to the claim, whichever is earlier. **IN NO EVENT SHALL ARMSTRONG BE LIABLE FOR SPECIAL, DIRECT, INDIRECT, INCIDENTAL OR CONSEQUENTIAL DAMAGES, INCLUDING, BUT NOT LIMITED TO, LOSS OF USE OR PROFITS OR INTERRUPTION OF BUSINESS.** The Limited Warranty and Remedy terms herein apply notwithstanding any contrary terms in any purchase order or form submitted or issued by any user, purchaser, or third party and all such contrary terms shall be deemed rejected by Armstrong.



# **Emech<sup>®</sup>**

## **Steam Water Mixing Valve**

### **Model F2**

# **Installation, Operation & Maintenance**

## **Manual**

*Designs, materials, weights and performance ratings are approximate and subject to change without notice.*  
Visit [armstronginternational.com](http://armstronginternational.com) for up-to-date information.



**Armstrong** International  
North America • Latin America • India • Europe / Middle East / Africa • China • Pacific Rim  
[armstronginternational.com](http://armstronginternational.com)