

Armstrong Nanobubble Generator



Please read and save
these instructions

General Safety Information

Icon Legend:



— **DANGER!** ... Injury or death and property damage are *imminent*



— **WARNING!** ... Injury or death and property damage are *possible*



— **CAUTION!** ... Potential property damage, expensive repairs, and/or voiding the equipment warranty *may result*



BURN HAZARD! Direct exposure to steam, hot water, or hot metal surfaces can cause severe skin burns. Skin contact with 140°F (60°C) water or metal for only five (5) seconds may cause a second-degree burn.

Failure to comply with instructions following a safety icon may result in adverse consequences including, property damage, personal injury, or, in extreme cases, death.

General Safety Guidelines:

1. Inappropriate use of this product (beyond typical, intended use) could cause damage to the product and other property. It may also result in personal injury or, in extreme cases, death.
2. Only designated, qualified, and competent personnel should conduct installation, maintenance, and service in accordance with the directions in this product instruction manual.
3. Installation shall comply with all applicable federal, state, and local, electrical and construction, regulatory codes.
4. Improper installation, start-up, operation, maintenance, or service may void the product warranty.
5. When installing, commissioning or servicing this product:
 - a. ALWAYS select and wear appropriate personal protective equipment (PPE) before carrying out any physical work at the job site. Appropriate PPE may include hard hats, safety glasses, gloves, boots or shoes w/ non-slip soles and toe guards, and protective overalls.
 - b. ALWAYS scan the work area and take note of potential hazards before entering. Adjust your travel path or work position to avoid hazards and personal injury.
 - c. ALWAYS observe designated safety procedures when working in hazardous locations (areas containing explosive and combustible gases, vapors, and dusts) and confined spaces (locations where the breathable air supply may be limited or variable or where entrapment could occur).
 - d. ALWAYS use appropriate lockout-tagout procedures to disconnect power sources and de-energize machinery before conducting installation, service, and repair.
 - e. ALWAYS use great care and appropriate safety gear when working above ground level, especially on ladders and platforms or in the presence of overhead, electrical power lines.
 - f. ALWAYS ensure that all “live” steam, water supply, and condensate return lines are isolated before breaking or loosening any plumbing joints.
 - g. ALWAYS carefully relieve any residual internal pressure in the system or connecting pipe work before breaking or loosening any plumbing joints.
 - h. ALWAYS allow hot parts to cool before commencing work to avoid the risk of skin burns.

Table of Contents

- 1. Product Description 4
- 2. Applications 4
- 3. Product Operation 5
- 4. Product Installation 6
- 5. Application Schematics 7–9
- 6. Installation, Validation and Ongoing Monitoring Protocols 10–11
- Warranty 12

1. Product Description

The Armstrong Nanobubble Generator ANG is a proven solution for the inhibition and removal of scale in hot water systems. This patent pending technology is easily installed, has no moving parts, requires no maintenance or additional electrical inputs, and uses no chemicals. Whether it's on a heat exchanger or strategically placed within the hot water piping infrastructure to address the entire system, the Nanobubble Generator significantly reduces scale, which improves the overall health of the hot water system and drives operational efficiencies, leading to a smaller carbon footprint.

Nanobubble Generator Models

Model	Typical Flow Rate (GPM)*	Length Face to Face	Connection Size	Body Size	Approximate Weight
ANG20	1–7	34½”	Threaded ¾” NPT Female	1.5”	6 lb
ANG25	5–40	36¾”	Threaded 1” NPT Female	2”	9 lb
ANG50	15–110	51½”	150 lb Flange 2”	3”	48 lb
ANG80	25–225	53”	150 lb Flange 3”	4”	78 lb
ANG100	50–550	98½”	150 lb Flange 4”	6”	120 lb
ANG150	200–1150	102”	150 lb Flange 6”	8”	200 lb

2. Applications

Standard applications* include but are not limited to the following:

- Open Condenser Water Systems
- Closed Loop Hydronic Water Systems (Heating and Cooling)
- Water Used for Cleaning
- Domestic Hot Water Recirculation Systems
- Pool Systems

All applications—including those listed and not listed here—should be assessed by an appropriate engineer prior to installation. Questions regarding Armstrong or nanobubble generator installation should be directed to www.armstronginternational.com.

3. Product Operation

For ideal Nanobubble generation it is recommended that the model have a 5psi pressure drop across it. Pressure drops less than this will still result in Nanobubble creation, it will just take longer to saturate the system. Pressure drops greater than this will result in faster Nanobubble creation and system saturation.

Recommended Operating Ranges for Nanobubble Generators

ANG20		ANG25		ANG50		ANG80		ANG100		ANG150	
3/4"x 1-1/2"		1"x 2"		2"x 3"		3"x 4"		4"x 6"		6"x 8"	
GPM	Pressure Drop (psi)	GPM	Pressure Drop (psi)	GPM	Pressure Drop (psi)	GPM	Pressure Drop (psi)	GPM	Pressure Drop (psi)	GPM	Pressure Drop (psi)
0.8	1.9	5.0	1.9	5.0	0.6	30.0	1.5	50.0	0.9	200.0	1.8
1.1	2.5	6.7	2.5	10.0	0.6	40.0	2.0	75.0	1.4	250.0	2.3
1.4	3.1	8.3	3.1	15.0	0.6	50.0	2.5	100.0	1.9	300.0	2.8
1.7	3.8	10.0	3.8	20.0	0.6	60.0	3.0	125.0	2.3	350.0	3.2
1.9	4.4	11.7	4.4	25.0	1.3	70.0	3.4	150.0	2.8	400.0	3.7
2.2	5.0	13.3	5.0	30.0	1.3	80.0	3.9	175.0	3.3	450.0	4.2
2.5	5.6	15.0	5.6	35.0	2.5	90.0	4.4	200.0	3.8	500.0	4.6
2.8	6.3	16.7	6.3	40.0	3.1	100.0	4.9	225.0	4.2	550.0	5.1
3.1	6.9	18.3	6.9	45.0	3.8	110.0	5.4	250.0	4.7	600.0	5.5
3.3	7.5	20.0	7.5	50.0	4.4	120.0	5.9	275.0	5.2	650.0	6.0
3.6	8.1	21.7	8.1	55.0	4.4	130.0	6.4	300.0	5.6	700.0	6.5
3.9	8.8	23.3	8.8	60.0	5.0	140.0	6.9	325.0	6.1	750.0	6.9
4.2	9.4	25.0	9.4	65.0	5.0	150.0	7.4	350.0	6.6	800.0	7.4
4.4	10.0	26.7	10.0	70.0	6.3	160.0	7.9	375.0	7.0	850.0	7.8
4.7	10.6	28.3	10.6	75.0	6.3	170.0	8.4	400.0	7.5	900.0	8.3
5.0	11.3	30.0	11.3	80.0	7.5	180.0	8.9	425.0	8.0	950.0	8.8
5.3	11.9	31.7	11.9	85.0	8.1	190.0	9.4	450.0	8.4	1000.0	9.2
5.6	12.5	33.3	12.5	90.0	8.8	200.0	9.8	475.0	8.9	1050.0	9.7
6.1	13.8	36.7	13.8	95.0	10.0	210.0	10.3	500.0	9.4	1100.0	10.2
6.4	14.4	37.5	14.1	100.0	12.5	220.0	10.8	525.0	9.8	1150.0	10.6
6.7	15.1	39.3	14.7	110.0	15.0	230.0	11.3	550.0	10.3	1200.0	11.1

4. Product Installation

The following instructions can be used as guidance for the installation of a patent-pending Armstrong nanobubble generator. Sizes range from 1 GPM to 1150 GPM with sidestream application. Applications and systems will vary and should be reviewed by experienced personnel prior to installation. A licensed mechanical contractor should perform the installation. Additional installation specifications for each model follow this overview.

Installing a Generator in an Existing System





1. Determine flow rate and existing pump capabilities OR calculate system volume and determine turnover rate, OR install a small recirculation pump and ANG to recirculate the HX or boiler.
2. Analyze increased pressure drop effect on system.
3. Select appropriate generator and pipe sizing.
4. Drain enough of the system to install tees and valves (see diagram below).
5. Install properly sized generator and piping (full or side stream).
6. Fill system.
7. Start pump.
8. Open generator isolation valves.
9. Shut off by-pass or balance to proper flow rate through generator.
10. Re-balance system, if necessary.
11. Monitor system for proper operation to maximize ANG effect, the system should recirculate 24/7.

To install a Generator in a NEW System, omit steps 2 and 4.

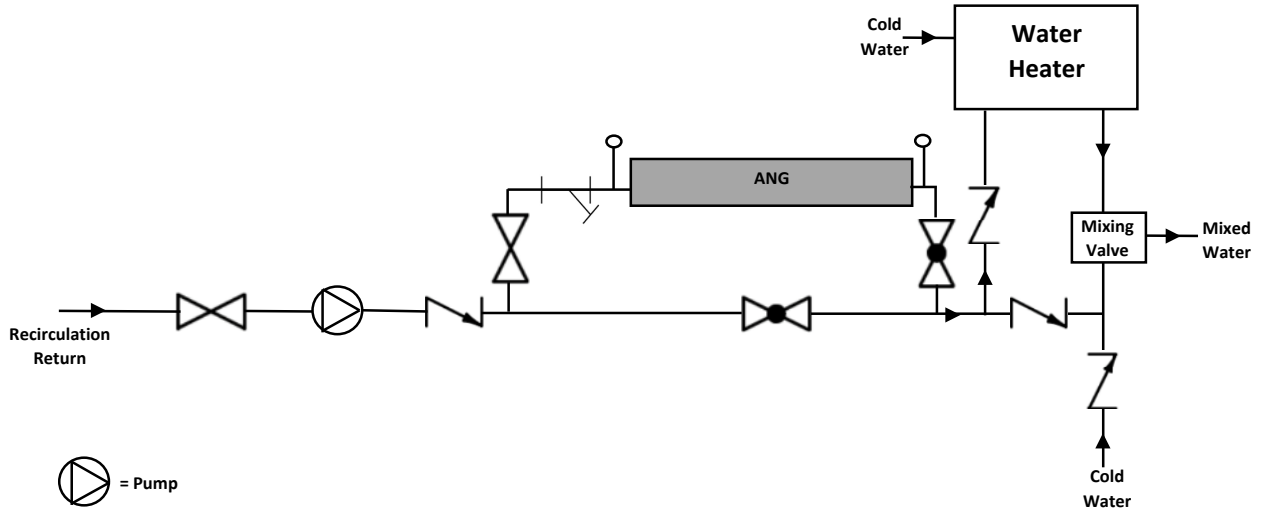
1. Determine flow rate and existing pump capabilities.
2. Analyze increased pressure drop effect on system.
3. Select appropriate generator and pipe sizing.
4. Drain enough of the system to install tees and valves (see diagram below).
5. Install properly sized generator and piping (full or side stream).
6. Fill system.
7. Start pump.
8. Open generator isolation valves.
9. Shut off by-pass or balance to proper flow rate through generator.
10. Re-balance system, if necessary.
11. Monitor system for proper operation.





5. Application Schematics

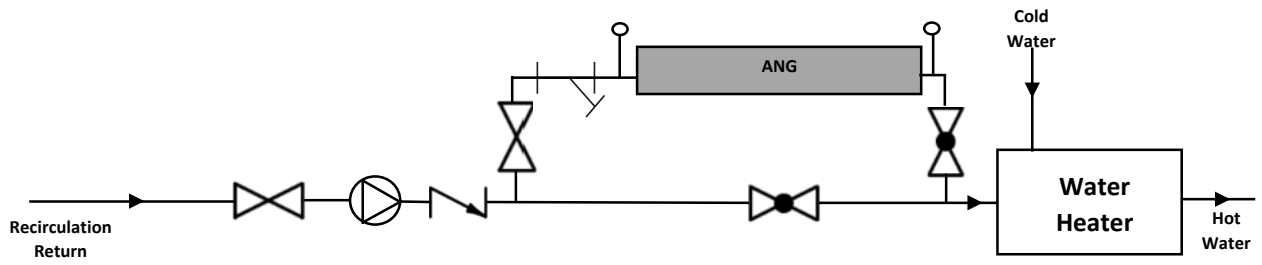

-  = Pump
-  = Isolation Valve
-  = Combination Isolation/Balance Valve
-  = Strainer
-  = Check Valve

Recirculation w/ Mixing Valve



-  = Pump
-  = Isolation Valve
-  = Combination Isolation/Balance Valve
-  = Strainer
-  = Check Valve

Recirculation w/o Mixing Valve

5. Application Schematics—continued

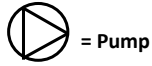
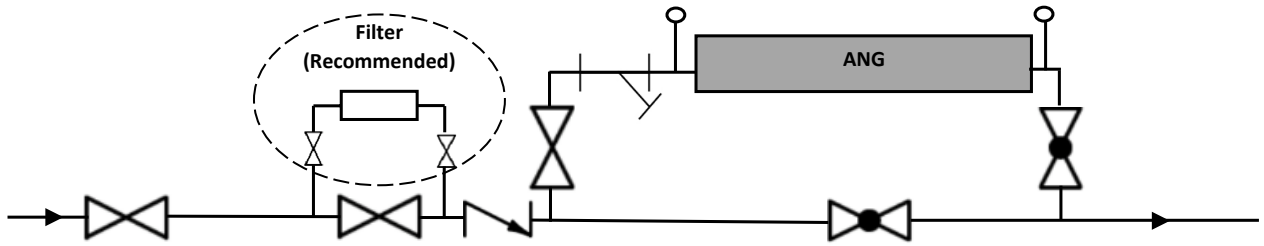

= Pump

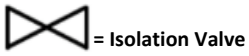

= Isolation Valve



= Combination Isolation/Balance Valve

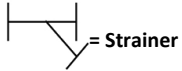

= Strainer

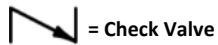

= Check Valve

Single Pass

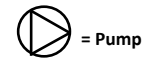
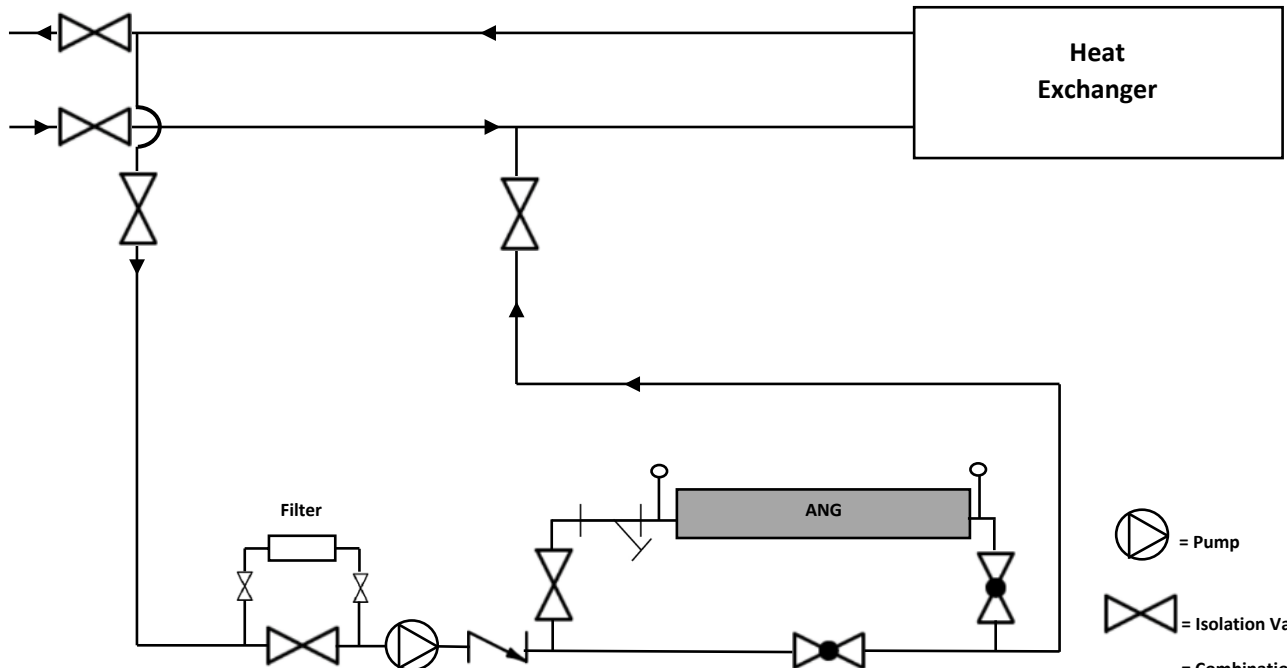

= Pump

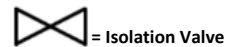

= Isolation Valve

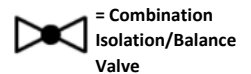

= Combination Isolation/Balance Valve

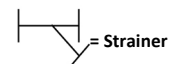

= Strainer

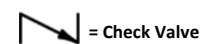

= Check Valve

CIP

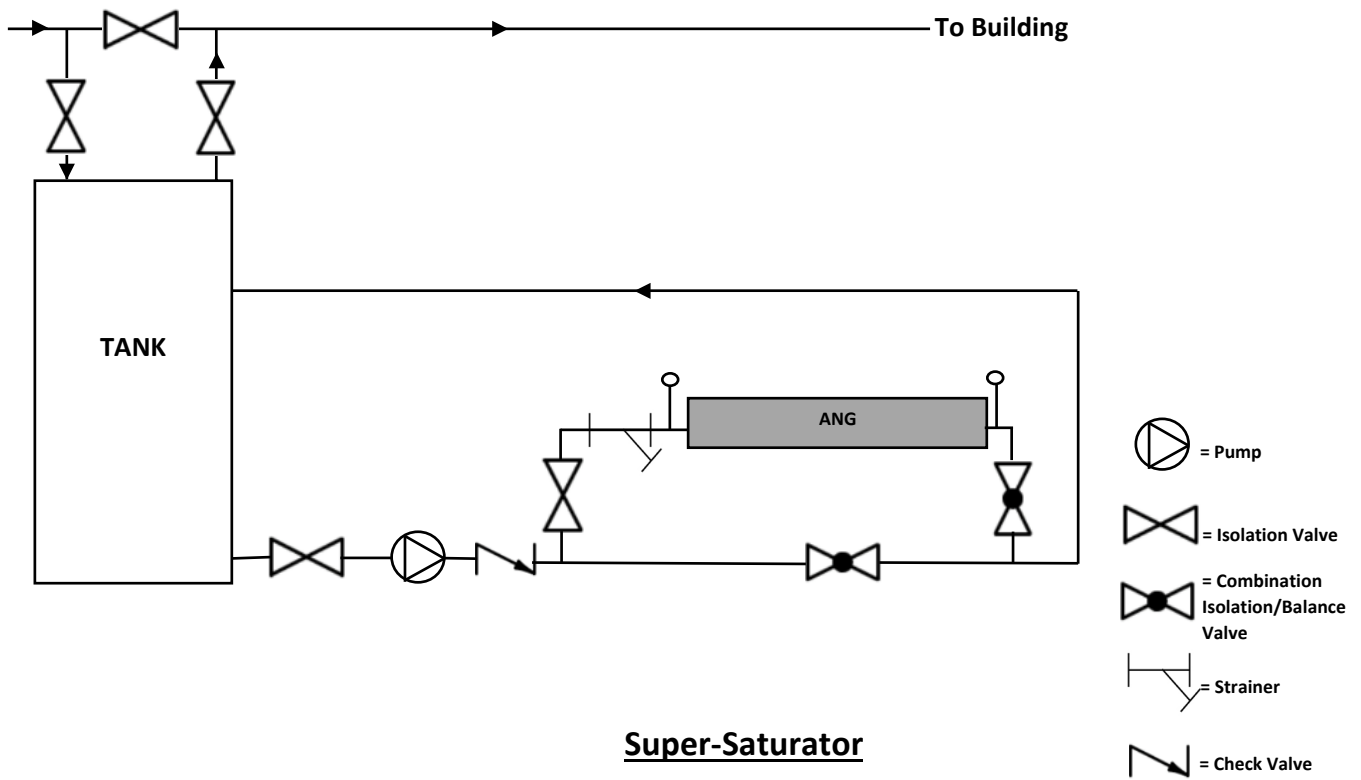

6. Installation, Validation, & Ongoing Monitoring Protocols

Key References – WICRA (Water Infection Control Risk Assessment), TJC (The Joint Commission), TIR 34 (Technical Information Report), AAMI ST79 (Association for the Advancement of Medical Instrumentation), WMP (Facility Water Management Plan), NSF/ANSI 61 (National Science Foundation/American National Standards Institute), Water Infection Control Risk Assessment (WICRA).

1. Planning Phase

- a. The Facility shall develop a water sampling, testing, flushing, and ongoing monitoring (STFM) plan before installation of the ANG which will be followed throughout the installation, start-up, and post-install monitoring time. The Facility shall recommend a third-party review of the STFM for sufficiency. Elements of this plan are as follows:
 1. Review current water systems testing, monitoring, and treatment plan, including existing WICRA and WMP, for a compatible and complimentary overall strategy for the affected portion(s) of the Facility. Additional testing, monitoring, flushing and treatment may be added to existing WMP based on a ANG risk assessment.
 2. The Facility may perform its own ANG risk assessment for systems that could be affected to inform the installation, validation, and ongoing monitoring phases. For example, collection points of biofilm debris, e.g., aerators, water hammer arrestors, and in-line filters, including integral filters, e.g., integral biofilters in disinfection-type medical equipment or ice machines, which are not easily cleaned by flushing.
 3. The Facility should conduct baseline microbial sampling and water quality testing at control points per the Facility's WMP. Additional locations could be added as determined by the ANG risk assessment, part 1.a.ii above.
 4. As part of the planning phase, the Facility should assess the need for strainers and filters installed and maintained by the Facility during start-up and ongoing if desired. See 2.a below.

2. Installation Phase

- a. The Facility shall install an in-line strainer (type and size may vary with a screen mesh of 40 as a good rule of thumb) upstream of the nanobubble water treatment device and routine cleaning should be included in the Facility's maintenance schedule.
- b. The Facility may choose to install filters to protect distal points per the STFM. Include routine inspection and cleaning in the Facility's maintenance schedule.

- c. The Facility shall flush the system upon start-up of the ANG. The Facility should continue following the flushing protocol per their WMP or updated WMP that includes ANG protocols, see 1.a.i above. Note: if the protocol has a rotation of flushing distal points (not all performed on the same unit of time), supplemental testing of the system served by the ANG should be added.
- d. The Facility shall conduct microbial sampling and water quality testing at control points per the STFM and the Facility's WMP and/or updated ANG WMP.

3. Validation Phase

1. The validation phase serves to independently ensure the safety of the water treated by the ANG as compared to baseline, and to validate the efficacy of the ANG in improving water quality for the Facility.
2. If Facility chooses to do so; A third party shall conduct and/or oversee microbial sampling and/or water quality testing at control points per part 1.a.iii above. The testing may be conducted by the facility maintenance personnel defined in the WMP (the WMP or updated ANG WMP must include training of Facility maintenance personnel who will be responsible for sample collection, proper handling (sterility, temperature, holding time and transportation of samples, as well as PPE) if applicable).
3. The third party shall receive, analyze, and report the independent laboratory data to the Facility.
4. Once validation of the system has been achieved and safety and efficacy have been approved, validated water quality may serve as the new baseline for ongoing monitoring, see below.
5. After the ANG efficacy is validated, the Facility shall update maintenance and cleaning schedules in the WMP to reflect the needs of the new system addition.

4. Ongoing Monitoring Phase

- a. The purpose of the ongoing monitoring phase is to ensure the achieved ANG water quality improvements and/or validated baselines, are maintained.
- b. The ongoing monitoring phase should be conducted or overseen by a third party, and should include control limits, control measures, corrective actions, and contingency response per the STFM and the Facility's WMP and/or updated ANG WMP.
- c. As with the validation phase, trained Facility maintenance personnel may collect samples. Independent laboratory data receipt, analysis, interpretation, and reporting are the responsibility

of the third-party consultant. Recommendations for corrective actions are the responsibility of the third-party consultant. Implementation of the corrective actions are the responsibility of the Facility.

- d. Validation of corrective actions should follow the validation phase as per 3.a-d above, prior to resuming ongoing monitoring.

Definitions:

Biofilm: Densely packed communities of microbial cells that grow on living or inert surfaces and surround themselves with secreted polymers.

Building water systems: Includes hot and cold-water distribution and all devices that use water. This can include items, such as hot tubs, decorative fountains, and cooling towers.

Control: To manage the conditions within your building according to your water management program.

Building Water Management Program (WMP): a facility or system policy prescribing controls, control limits, control measures, and control points, contingency response, and corrective actions to maintain acceptable levels to protect patients, team members, and visitors from water borne pathogens.

Control limits: The maximum value, minimum value, or range of values that are acceptable for the control measures that you are monitoring to reduce the risk for Waterborne pathogens growth and spread.

Control measures: Engineering controls and practices you implement in your building water system to limit growth and spread of Waterborne pathogens, such as heating, adding disinfectant, or cleaning.

Control points: Distal points in the water systems where a control measure can be applied.

Contingency response: Reaction to control measures that are persistently outside of control limits or events that pose an immediate risk to control of your building water systems; required for all instances when Legionnaires' disease occurs, but may also be appropriate for unexpected events such as equipment failure or acts of nature that disrupt the water system.

Corrective action: Steps taken to return control measures to acceptable levels.

Dead legs: Piping that is subject to low or no flow due to design or decreased water use such as capped pipes or unused faucets.

Disinfectant: Chemical or physical treatment used to kill germs, such as chlorine, monochloramine, chlorine dioxide, copper-silver ionization, ultraviolet light, or ozone.

Distal point: a location near the end of a distribution system branch where water is dispensed, and potential stagnation can occur based on usage.

Filtering: Removes small contaminants that may pass through a strainer.

Hazardous conditions: Anything that, if not controlled, can contribute to the growth, and spread of water borne pathogens to a person.

Heterotrophic plate counts: A measure of the number and variety of bacteria that are common in water; a high count may indicate a high microbial load and the need for corrective action but cannot be substituted for Waterborne pathogens testing.

Waterborne pathogens: Bacteria of fungal genus which encompasses species that can cause disease.

IOM: Installation, Operation, and Maintenance manual

PPE: Personal Protective Equipment

Residual: The amount of disinfectant available in water to kill microbes

Scale and sediment: The mineral build-up in a water system that uses up disinfectant and supports microbial growth and/or survival.

Stagnation: When water does not flow well, areas of stagnant water encourage biofilm growth and reduce temperature and level of disinfectant.

Straining: Removes larger contaminants and smaller contaminants may pass through.

Water Infection Control Risk Assessment (WICRA): CDC's risk assessment tool for water systems in facilities designed to prevent water borne pathogen exposure. This risk assessment may recommend and provide details to be included in the Facility's WMP.

Limited Warranty and Remedy

Armstrong International, Inc. or the Armstrong division that sold the product (“Armstrong”) warrants to the original user of those products supplied by it and used in the service and in the manner for which they are intended, that such products shall be free from defects in material and workmanship for a period of five (5) years from the date of installation, [unless a Special Warranty Period applies, as listed below]. This warranty does not extend to any product that has been subject to misuse, neglect or alteration after shipment from the Armstrong factory. Except as may be expressly provided in a written agreement between Armstrong and the user, which is signed by both parties, Armstrong **DOES NOT MAKE ANY OTHER REPRESENTATIONS OR WARRANTIES, EXPRESS OR IMPLIED, INCLUDING, BUT NOT LIMITED TO, ANY IMPLIED WARRANTY OF MERCHANTABILITY OR ANY IMPLIED WARRANTY OF FITNESS FOR A PARTICULAR PURPOSE.**

The sole and exclusive remedy with respect to the above limited warranty or with respect to any other claim relating to the products or to defects or any condition or use of the products supplied by Armstrong, however caused, and whether such claim is based upon warranty, contract, negligence, strict liability, or any other basis or theory, is limited to Armstrong’s repair or replacement of the part or product, excluding any labor or any other cost to remove or install said part or product, or at Armstrong’s option, to repayment of the purchase price. As a condition of enforcing any rights or remedies relating to Armstrong products, notice of any warranty or other claim relating to the products must be given in writing to Armstrong: (i) within 30 days of last day of the applicable warranty period, or (ii) within 30 days of the date of the manifestation of the condition or occurrence giving rise to the claim, whichever is earlier. **IN NO EVENT SHALL ARMSTRONG BE LIABLE FOR SPECIAL, DIRECT, INDIRECT, INCIDENTAL OR CONSEQUENTIAL DAMAGES, INCLUDING, BUT NOT LIMITED TO, LOSS OF USE OR PROFITS OR INTERRUPTION OF BUSINESS.** The Limited Warranty and Remedy terms herein apply notwithstanding any contrary terms in any purchase order or form submitted or issued by any user, purchaser, or third party and all such contrary terms shall be deemed rejected by Armstrong.

*Designs, materials, weights and performance ratings are approximate and subject to change without notice.
Visit armstronginternational.com for up-to-date information.*



Armstrong International
North America • Latin America • India • Europe / Middle East / Africa • China • Pacific Rim
armstronginternational.com