



# INSTALLING, OPERATING & MAINTAINING

# ABH-XL

## 800–1500 High Efficiency Water Heaters and Heating Boilers



**800–1500**  
795,000 BTU/hr  
999,999 BTU/hr  
1,475,000 BTU/hr

**Do not store or use gasoline or other flammable vapors and liquids in the vicinity of this or any other appliance.**

### WHAT TO DO IF YOU SMELL GAS:

- Do not try to light any appliance
- Do not touch any electrical switch
- Do not use any phone in your building

Immediately call your gas supplier from a neighbor's phone. Follow the gas supplier instructions. If you cannot reach your gas supplier, call the fire department.



ANSI Z21.10.3/CSA 4.3-2019,  
ANSI Z21.13/CSA 4.9-2017,  
UL 795-2016, CGA 3.4-2020

SCAQMD  
Compliant Rule 1146.2

### **WARNING**

**If the information in this manual is not followed exactly, a fire or explosion may result causing property damage, personal injury or death.**

### **WARNING**

These appliances **MUST** be installed by a properly licensed individual in the City and State which the unit is being installed. All start up adjustments and subsequent service work must be done by a similarly licensed contractor or a factory trained service individual. Failure to comply could result in loss of warranty and or severe personal injury, death and or substantial property damage. **These instructions are required to be kept with the appliance on the left side, in the pocket provided.**

## USING THIS MANUAL

Throughout this manual you will see these special attention boxes similar to those below, which are intended to supplement the instructions and make special notice of potential hazards. These categories are in the judgment of the Manufacturer.



### DANGER

Indicates a condition or hazard which **MAY** cause severe personal injury, death, or major property damage.



### CAUTION

Indicates a condition or hazard which **MAY** cause severe personal injury, death, or major property damage.



### WARNING

Indicates a condition or hazard which **MAY** cause severe personal injury, death, or major property damage.



### WARNING

- THE VENT SYSTEM IS RATED AND DESIGNED TO BE 2 PIPE SEALED COMBUSTION ONLY, POLYPROPYLENE (PP), PVC SCH 40 OR CPVC SCH 40 OR 80 OR AL 29-4C STAINLESS VENTING FOR ALL MODELS. A FACTORY ENGINEERED VENTING SYSTEM MAY ALLOW FOR EXCEPTIONS; CONSULT FACTORY FOR DETAILS.
- THIS APPLIANCE INSTALLATION MUST CONFORM TO THE LATEST EDITION OF THE "NATIONAL FUEL GAS CODE" ANSI Z223.1 NFPA 54 AND/OR CAN/CGAB149 INSTALLATION CODES. STATE AND LOCAL CODES MIGHT ALSO APPLY TO INSTALLATION.
- WHERE REQUIRED BY THE AUTHORITY HAVING JURISDICTION, THE INSTALLATION MUST CONFORM TO THE STANDARDS FOR CONTROLS AND SAFETY DEVICES FOR AUTOMATICALLY FIRED APPLIANCES, ANSI/ASME APPLIANCE AND PRESSURE VESSEL CODE, SECTION IV, ALONG WITH CSD-1.
- THE APPLIANCE, GAS PIPING, WATER PIPING, VENTING AND ELECTRICAL MUST BE INSTALLED BY TRAINED & QUALIFIED PERSONNEL FAMILIAR WITH INSTALLATION PRACTICES, LOCAL CODE, AND LICENSING REQUIREMENTS.
- IF THE INFORMATION IN THESE INSTRUCTIONS ARE NOT FOLLOWED EXACTLY, A FIRE OR EXPLOSION MAY RESULT, CAUSING PROPERTY DAMAGE, PERSONAL INJURY, OR DEATH.
- DO NOT STORE OR USE GASOLINE OR OTHER FLAMMABLE VAPORS AND LIQUIDS IN THE VICINITY OF THIS OR ANY OTHER APPLIANCE.

# TABLE OF CONTENTS

<b>USING THIS MANUAL .....</b>	<b>2</b>	<b>PART 6. START-UP PROCEDURES.....</b>	<b>48-56</b>
<b>TABLE OF CONTENTS .....</b>	<b>3</b>	A. Items to be Checked Before Lighting the Appliance .....	48
<b>PART 1. GENERAL INFORMATION .....</b>	<b>4-17</b>	B. Lighting Instructions.....	48-49
A. How it Operates.....	4-7	C. Operating Instructions.....	49
B. Appliance Controls.....	8	D. INI Process and Service Procedures.....	49-51
C. Appliance Control Board (Bcb) Screens .....	9-10	E. Adjusting the Temp on the Appliance Display...52-53	
D. Cascade Display Functions .....	11-13	F. Sequence of Operation.....	54
E. Glossary.....	14	G. 0-10v Direct Control .....	54-55
F. Dimensions.....	15-16	H. Outdoor Reset Function.....	56
G. Pre-Installation Requirements.....	16-17	<b>PART 7. SERVICE AND MAINTENANCE .....</b>	<b>57-63</b>
H. Pressure Relief Valve.....	17	A. Servicing the Appliance.....	57
<b>PART 2. ELECTRICAL .....</b>	<b>18-21</b>	B. Placing the Appliance into Normal Operation .....	57
A. Electrical Connection/Requirements .....	18	C. Testing the Manual Reset High Limit.....	57-58
B. Internal Wiring Connection .....	18-21	D. Soft Lockout Codes .....	59-60
<b>PART 3. GAS CONNECTION.....</b>	<b>22-27</b>	E. Appliance Hard Lockout Codes .....	61
A. Gas Connection and Inspection.....	22	F. To Turn Off Gas to the Appliance .....	62
B. Gas Piping.....	22	G. Pump & Wiring Control .....	62
C. Gas Tables.....	23	H. Status Readings.....	63
D. Gas Valve Setup.....	23-24	I. Appliance Sensor Resistance Table.....	63
E. Setting the Maximum Load .....	25-26	<b>PART 8. MAINTENANCE.....</b>	<b>64-66</b>
F. Setting the Minimum Load.....	26	A. Periodic Maintenance And Inspections.....	64
G. Gas Conversion .....	27	B. Annual Inspection.....	65
<b>PART 4. VENTING .....</b>	<b>28-38</b>	C. Heat Exchanger Anti-Scaling Prevention Feature...66	
A. Approved Venting Materials.....	28	<b>PART 9. SPECIAL INSTALLATION REQS.....</b>	<b>67-68</b>
B. Venting the Appliance.....	29-36	A. Installation Requirements—Massachusetts.....	67
C. Inlet Air Vent.....	37	B. Installation at High Altitudes.....	68
D. Venting Runs that Exceed Maximum Combined Length.....	37	<b>PART 10. PARTS BREAKDOWN .....</b>	<b>69-71</b>
E. Condensate Requirements.....	38	<b>PART 11. WARRANTY INFORMATION .....</b>	<b>72</b>
<b>PART 5. PIPING.....</b>	<b>39-47</b>	A. Warranty Contact Information.....	72
A. Hydronic Heating Boiler Piping.....	39		
B. Boiler Schematic Drawings .....	40		
C. Fill & Purge Heating System.....	41		
D. Water Heating Piping .....	42		
E. Water Heating Schematic Drawings .....	43-47		

## PART 1. GENERAL INFORMATION

### A. HOW IT OPERATES

The appliance product line is a high efficiency water heating product, requiring special venting and condensate removal precautions. All high efficiency condensing appliances will require more maintenance (cleaning) than their non-condensing counterparts. Failure to do so may result in damage to the appliance that is not covered under warranty. Failure to follow all of the instructions contained in this manual may also cause premature product failure that may not be covered under warranty.

This appliance has built-in freeze protection, automatically activating the circulation pump when the internal water temperature drops below 41°F. If the internal water temperature drops to 37°F, a burn cycle will be initiated and will shut

down as soon as the supply water temperature has reached 50°F.

**Power and gas must be left on for this function to operate.**

The appliance's primary controller is the HOT™ control platform. The HOT™ controller uses BCB and BDB boards to operate all functions of needed control and safety. It contains sophisticated logic that allows it to operate at very precise temperatures while minimizing burner on/off cycling. When multiple units are operated as a Cascade to handle a common load, the control logic contains the ability to control all of the units as efficiently as one. Cascade operation is a factory-installed and programmed option, requiring a field wiring connection between appliances for operation.

**BCB=**  
**the internal Boiler Control Board.**

**BDB =**  
**the Boiler Display Board;**  
**human interface.**

**CCB =**  
**the internal Cascade Control Board.**

**CDB =**  
**the Cascade Display Board, human**  
**interface located in the face of the**  
**cabinet.**

BCB—Boiler Control Board

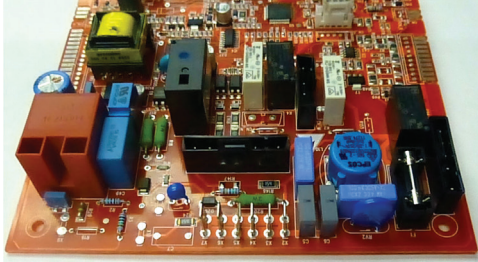

BDB—Boiler Display Board



CCB – Cascade Control Board

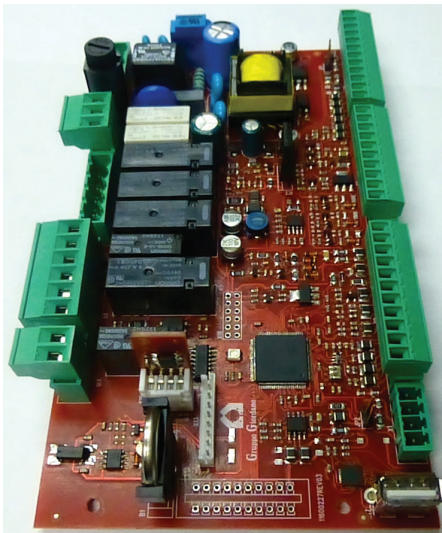

CDB - Cascade Display Board



EDB – Eeprom Data Board – contains all operating parameters of CCB and BCB

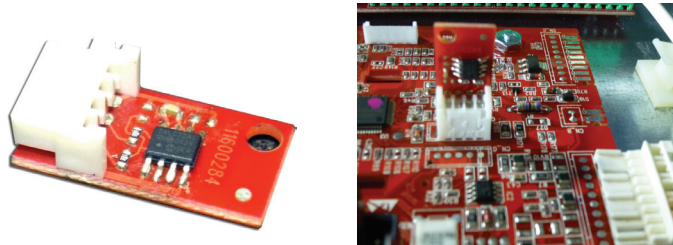

TYPICAL APPLIANCE DISPLAY AS PART OF A CASCADE



TYPICAL CASCADE DISPLAY



TYPICAL STAND ALONE APPLIANCE DISPLAY

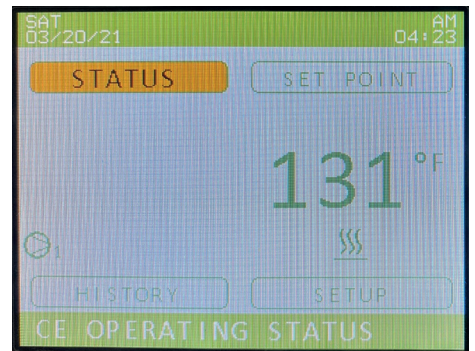

Typical Cascade display—Heating and Indirect Hot Water applications

Typical stand-alone appliance display—Heating and Indirect Hot Water applications

The bottom of the display contains a scrolling message related to the current status of the system (Cascade Display), or the appliance

**As a Stand Alone Appliance  
HOT™ CONTROL  
MENU NAVIGATION**

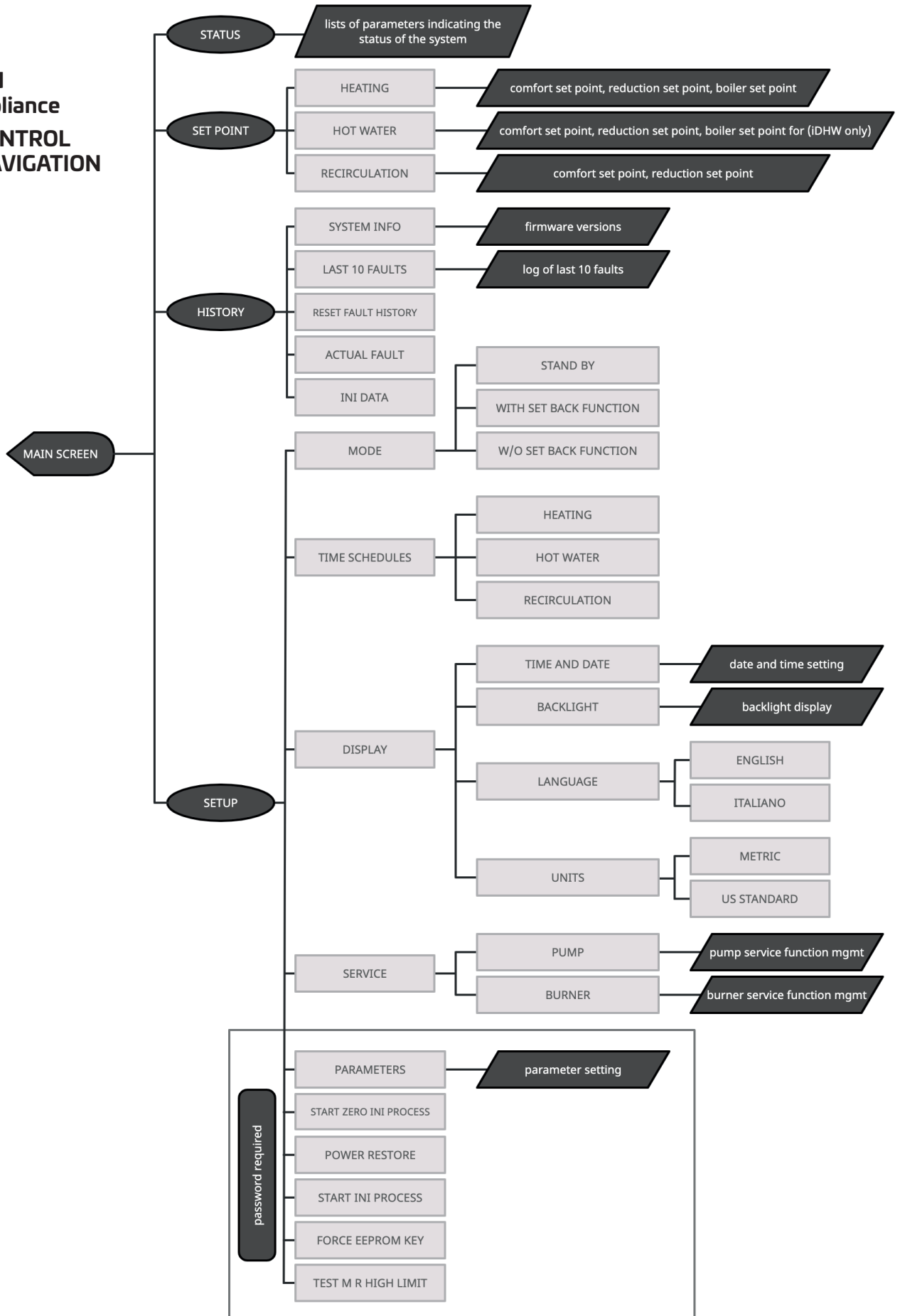

# Appliance as Part of a Cascade HOT™ CONTROL MENU NAVIGATION

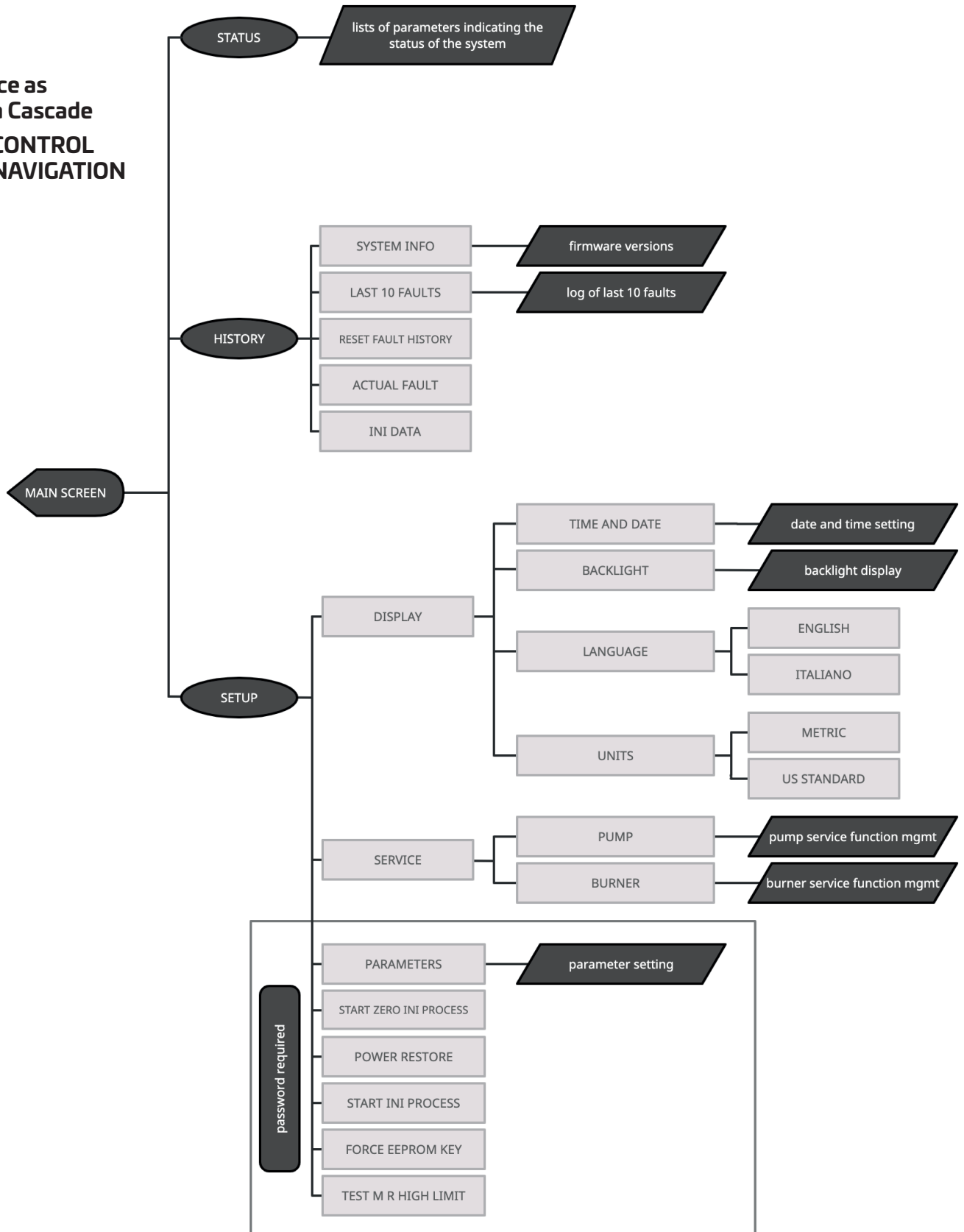

## B. APPLIANCE CONTROLS

The following components are found on the control panel on the front of the appliance.

- 1) POWER on/off switch
- 2) Display/Interface

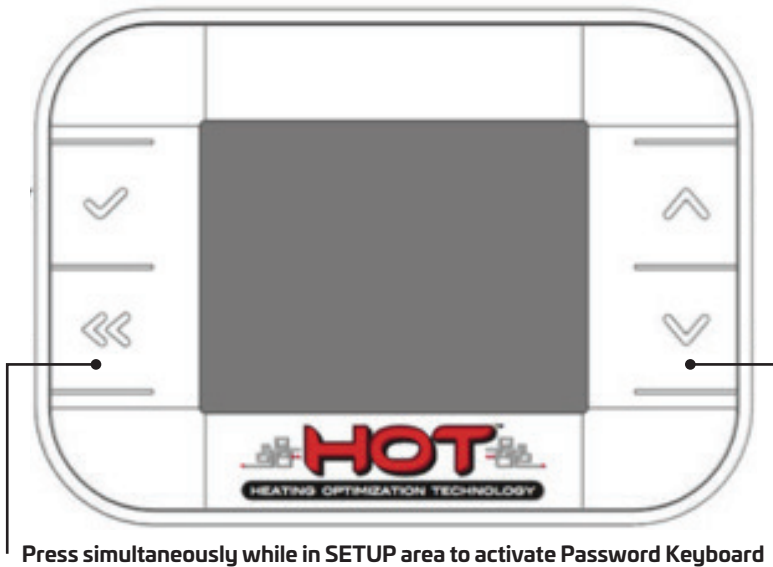
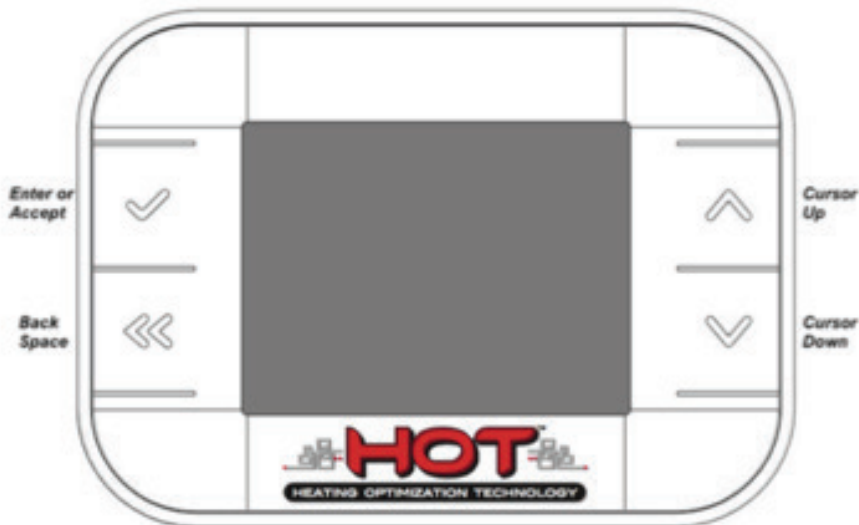

(FIGURE 1-1)  
APPLIANCE CONTROL PANEL

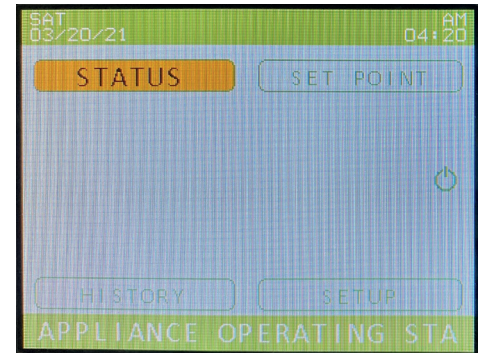

Standby Status

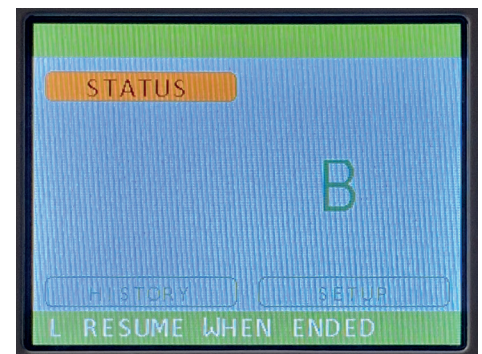

Normal Operating Status in Cascade

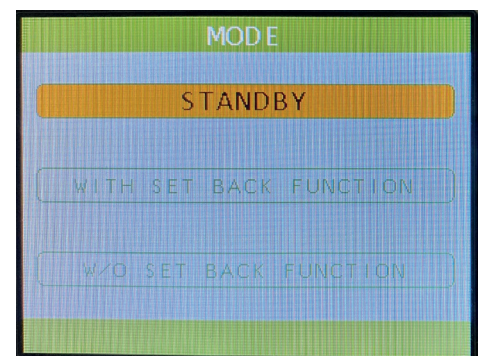

Normal Operating Status  
in single appliance

### C. APPLIANCE CONTROL BOARD (BCB) SCREENS

In the main screen it is possible to see:

- Set point value
- Type of system (icons)
- Date and time
- Labels for navigation through the controller (STATUS, SET POINT, HISTORY, SETUP)
- Information and tips
- Alarms (soft lockout yellow and hard lockout red)

Navigation and settings are allowed by using the arrow, ✓ and BACK buttons.

**Stand-By Mode:**

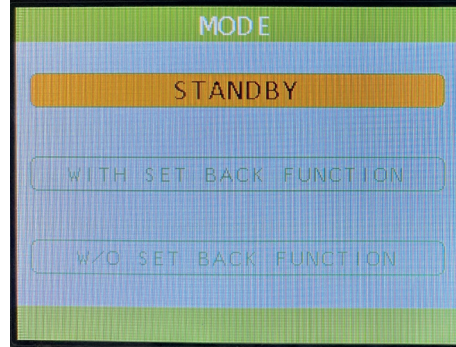

**Operating Mode:**

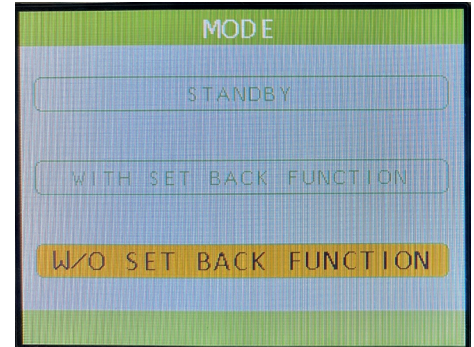

**Burner On (flame icon):**



**SLO Warning and Pump On Icon:**



**HLO Warning and Pump On Icon:**



**Entering SETUP functions area:**

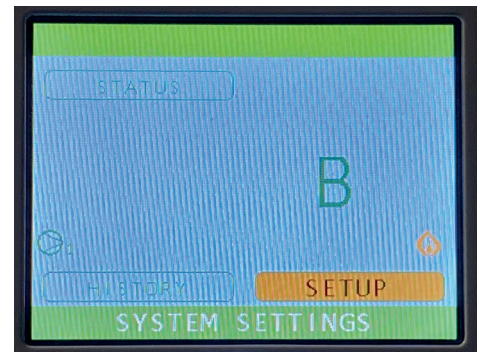

**C. APPLIANCE CONTROL BOARD (BCB) SCREENS (continued)**

In case of fault indication (SLO or HLO), the main page shows the code of the fault occurred. To see the extended description you have to go into HISTORY menu, where a new item "ACTUAL FAULT" will be displayed. In case an appliance RESET is required (HLO fault), it is possible to activate the RESET procedure entering the ACTUAL FAULT page and selecting the corresponding item.

**HISTORY then to view ACTUAL FAULT:**

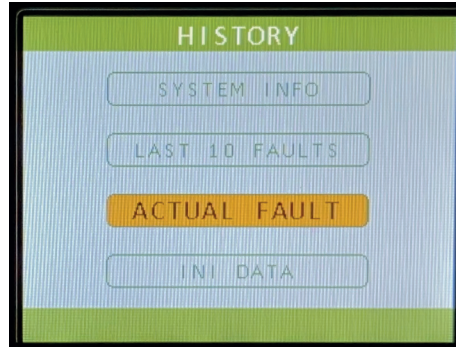

**ACTUAL FAULT (HLO):**

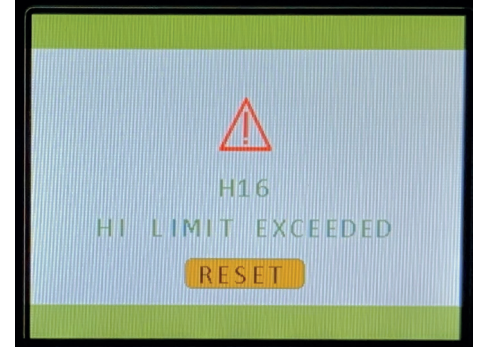

**Click ✓ button to RESET fault:**

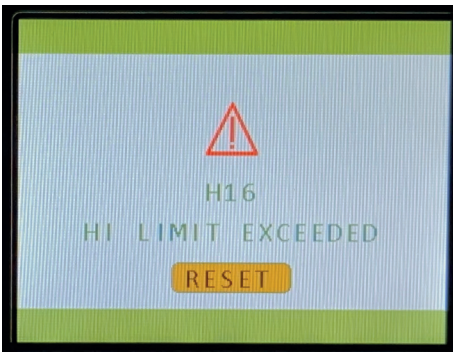

**LAST 10 FAULTS (SLO):**

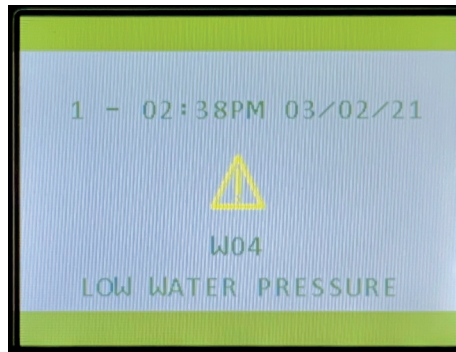

**HISTORY then SYSTEM INFO:**

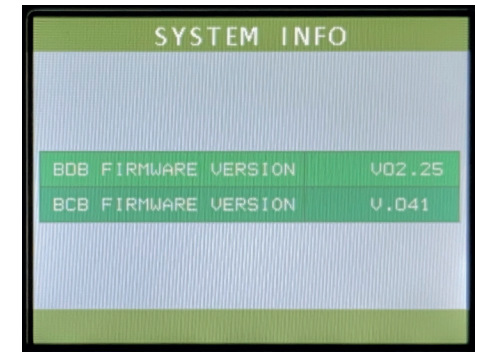

**SETUP then enter password mode:**

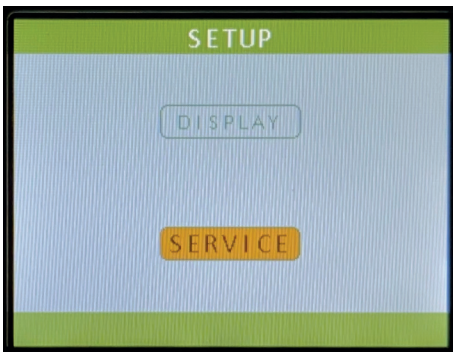

**Press to enter password mode:**

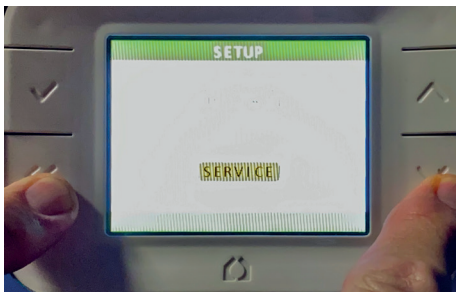

Press and hold simultaneously as shown

**PASSWORD Keyboard:**

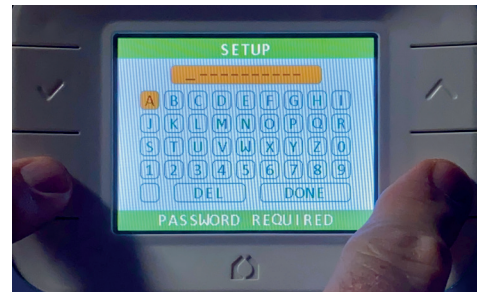

After reaching the letter you need, press the ✓ button then move to next

**PASSWORD entered then DONE:**

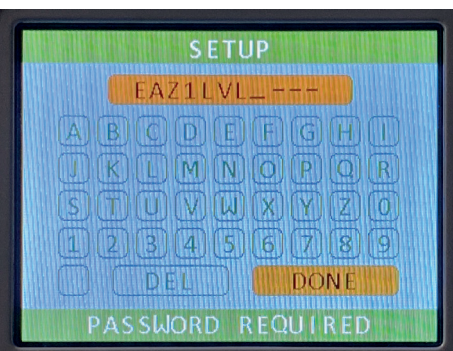

**Options in PASSWORD MODE:**



**Home screen during INI process:**

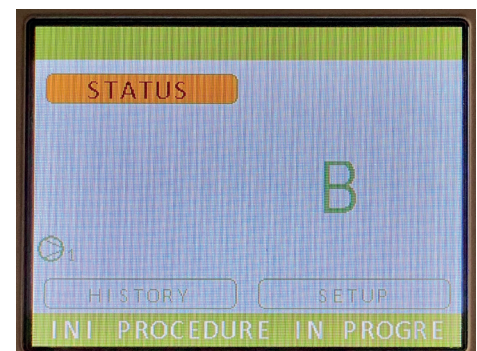

## D. CASCADE DISPLAY FUNCTIONS

Standby Mode:



Operating Mode (no demand):



Icons here indicate what mode the appliance is in

One or more appliances on:



Flashing icon indicates demand in process (iDHW):



Flame icon indicates that the appliance is in a burn cycle—shows proof of flame rectification

One or more appliances HLO:



STATUS/CASCADE: Sensor S2 not connected

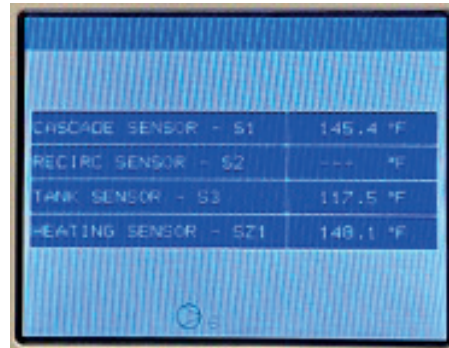

## D. CASCADE DISPLAY FUNCTIONS (continued)

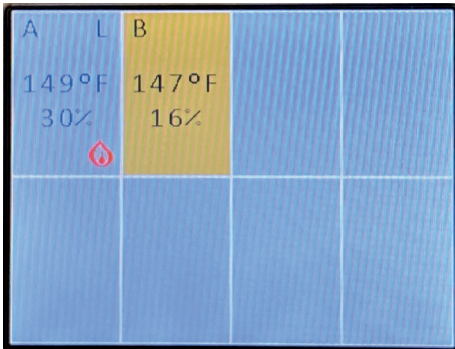

Appliance A is the lead as indicated by the L. The A appliance is also in a burn cycle illustrated by the flame icon. The fan speed is shown as a %. In common vent systems all appliances will have a minimum fan speed even if the appliance is not firing, as long as there is a call for heat.

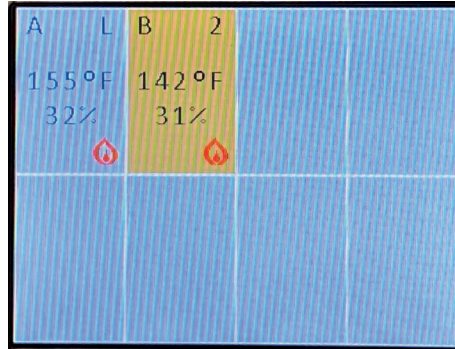

Both appliances are in a burn cycle. A is the lead and B is 2nd in line as indicated by the 2.

**Display screen save mode:**

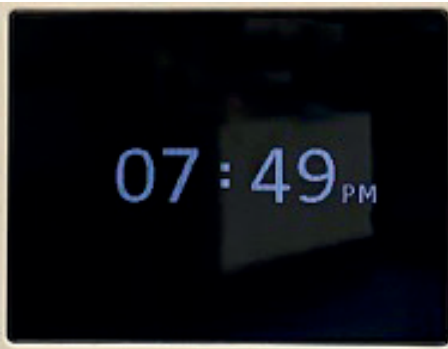

**Screen save with fault on one or more appliance:**

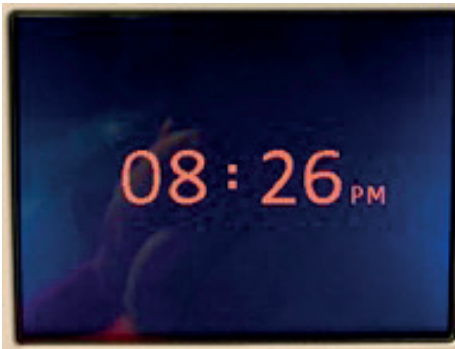

**(TABLE 1-1) SENSOR TABLES**

Number	Sensor Part Name - Part Number	Location - BCB - Boiler Control Board
T1.1	Supply temperature - Adjustable Manual Reset High Limit TST 75001 [D104920]	BCB - appliance outlet pipe
T1.2	Supply temperature p/n see above, duplex sensor	BCB - appliance outlet pipe
T2	Return temperature TST 75000 [D104919]	BCB - appliance header
T3*	Tank for iDHW and DHW temperature TST 76110 [D122338]	BCB to external component
T4*	Outdoor temperature TST 73010 [D119213]	BCB to external location
T5	Flue gas temperature TST 75002 [D104921]	BCB - appliance flue outlet
T6*	External system water temperature TST 76110 [D122338]	BCB - primary piping or Low Loss Header
TR1	Fan Air Pressure transducer PTR 12323 [D104963]	BCB - fan outlet
TR2	Gas Inlet pressure transducer PTR 12304 [D104962]	BCB - gas valve inlet

Number	Temperature Sensor Part Name	Location - CCB - Cascade Control Board
S1	Cascade system sensor - linked to Pump 4	CCB - primary piping or Low Loss Header
S2	DHW recirc sensor - linked to Pump 8	CCB Supply or return to zone with Pump 8, if the application is iDHW or DHW, it is used as the return line sensor to control Pump 8
S3	Tank iDHW or DHW sensor - linked to Pump 5	CCB - Cascade Control Board
S4	Load/Zone sensor - linked to Pump 6	CCB Supply or return to zone with Pump 6
S5	Load/Zone sensor - linked to Pump 7	CCB Supply or return to zone with Pump 7
S6	Outdoor sensor	CCB to external location
S7	Load/Zone sensor - linked to Pump 9	CCB Supply or return to zone with Pump 9

*Note: All temperature sensors (T1.1–T2, S1–S7) are 10k thermistors, all pressure transducers (TR1–TR5) are 5vdc. Transducers are specific to their purpose; pressure range, accuracy and media being measured; gas, water or air/gas.*

## E. GLOSSARY

- APS**  
Air pressure switch
- BCB**  
Boiler Control Board
- BDB**  
Boiler Display Board
- Blocking**  
Limit situation is touched, boiler OFF; when the safe situation is restored, boiler On.
- CCB**  
Cascade Control Board
- CDB**  
Cascade Display Board
- CH**  
Central Heating
- Condensate**  
Water vapor generated as a product of combustion, which has a low pH.
- DHL**  
Two independent sensors (high limit and outlet water) in a single well
- iDHW**  
Indirect Domestic Hot Water
- Diverter valve**  
Motorized valve with spring return
- DHW**  
Direct Hot Water production (instantaneous)
- Hard Lock Out (HLO)**  
A significant error or issue with the appliance or system, such as multiple failures to light or an unsafe pressure differential. An error code at this level will trigger a shutdown of the affected appliance(s). Service or repair is required.
- HLO**  
Hard Lock Out—Manual reset needed to restart the appliance
- HMI**  
Human Machine Interface
- Hysteresis**  
Blocking set temperature+ offset temperature—hysteresis is starting temperature for the boiler.
- ICM**  
Interface Cascade Manager (with or without WiFi)
- Indirect Tank**  
Sanitary hot water tank with a built in heat exchanger often used as a component in an iDHW system
- INI**  
Baseline data initialization, runs by default every 14 days
- Masterless Lead-lag System**  
In a multi-appliance system this control system will work all connected appliances as one large team. This insures smooth distribution of the work load and even aging of all appliances connected within.  
In addition, proprietary software manages common vented systems insuring equal back-pressure on all connected appliances and safe operation in the event of a component failure of one or more of connected appliances.
- Modbus**  
For Ethernet or RS232 or RS485 bus system for Lead and Leg communication
- Offset**  
Overriding temperature above set blocking: boiler OFF
- PAVO**  
Zone controller
- PCB**  
Printed circuit board—burner control board
- Soft Lock Out (SLO)**  
Manual reset or appliance reset needed for restart
- Tank**  
Domestic Hot Water Tank without internal heat exchanger
- 3-way-valve**  
Motorized valve: turning to the right and to the left
- Parameter**  
P followed by a letter and number (Ex: PS18 = parameter S-18)
- n.a.**  
Not applicable. Constant value.
- TBD**  
To be defined
- Z-INI**  
First INI process

F. DIMENSIONS

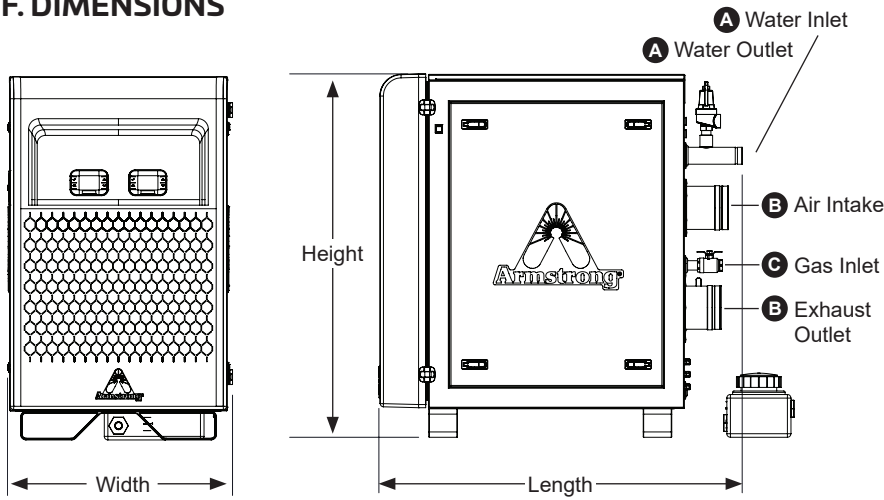

(TABLE 1-1) APPLIANCE DIMENSIONS

Heater/Boiler															
Model	Width		Height		Depth		A (VIC Groove)		B		C		Shipping Weight		
	in	mm	in	mm	in	mm	in	mm	in	mm	in	mm	lb	kg	
XL800	31.6	803.2	51	1295	51	1295	2	50	6	152	1	25	650	295	
XL1000	31.6	803.2	51	1295	69.2	1757.4	2	50	6	152	1	25	750	340	
XL1500	31.6	803.2	51	1295	69.2	1757.4	2	50	8	203	1.5	38	850	385	

(TABLE 1-2) HX DATA

Model	Input		Water Heater* Output		Boiler Output**		Recovery @ 100°FΔT (55.6°CΔT)		Recovery @ 80°FΔT (44.5°CΔT)		Recovery @ 60°FΔT (33.3°CΔT)		Water Flow Rate & Pressure Drop DHW †		Water Flow Rate & Pressure Drop Heating	
	BTU/Hr	kW	BTU/Hr	kW	BTU/Hr	kW	GPH	LPH	GPH	LPH	GPH	LPH	GPM@FT	LPM@M	GPM@FT	LPM@M
XL800	795,000	233	up to 771,150	up to 226	up to 755,250	up to 221	926	3,505	1,157	4,380	1,543	5,841	51.4@12'	195@3.7M	30.2@7'	114@2.1M
XL1000	999,999	293	up to 969,999	up to 284	up to 949,999	up to 278	1,164	4,406	1,456	5,512	1,941	7,348	64.7@15.2'	245@4.6M	38.0@8.5'	144@2.6M
XL1500	1,475,000	432	up to 1,430,750	up to 419	up to 1,401,250	up to 410	1,718	6,494	2,147	8,115	2,863	10,822	82.9@17.3'	314@5.3M	56.8@10.3'	215@3.1M

\*At 97% thermal efficiency with 86°F incoming water to heat exchanger  
 \*\*At 95% thermal efficiency with 140°F incoming water to heat exchanger

† Individual appliance piping pressure drop used in the tables is based on 20 feet of straight pipe, 6 elbows, 2 tees, 2 full port ball valves and 2 unions

ELECTRICAL CHARACTERISTICS FOR PRODUCTS

208 Volt Power Supply			
Model	Amps/unit	Boiler Pump	Total amps Boiler
HWH 800	4.44	0.47	4.91
HWH 1000	5.88	0.55	6.44
HWH 1500	9.17	0.96	10.13

240 Volt Power Supply			
Model	Amps/unit	Boiler Pump	Total amps Boiler
HWH 800	3.85	0.40	4.25
HWH 1000	5.1	0.48	5.58
HWH 1500	7.95	0.83	8.78

Model	Amps/unit	Heater Pump	Total amps Boiler
HWD 800	4.44	0.96	5.40
HWD 1000	5.88	1.32	7.21
HWD 1500	9.17	2.04	11.22

Model	Amps/unit	Heater Pump	Total amps Boiler
HWD 800	3.85	0.83	4.68
HWD 1000	5.1	1.15	6.25
HWD 1500	7.95	1.77	9.72

Note: No load switching is possible directly from the BCB or CCB, it may only switch a relay signal.

## F. DIMENSIONS (continued)

### RECOMMENDED SERVICE CLEARANCES

#### (FIGURE 1-2) APPLIANCES CLEARANCES

(NOTE: THE APPLIANCE IS RATED AT ZERO CLEARANCE TO COMBUSTIBLES.)

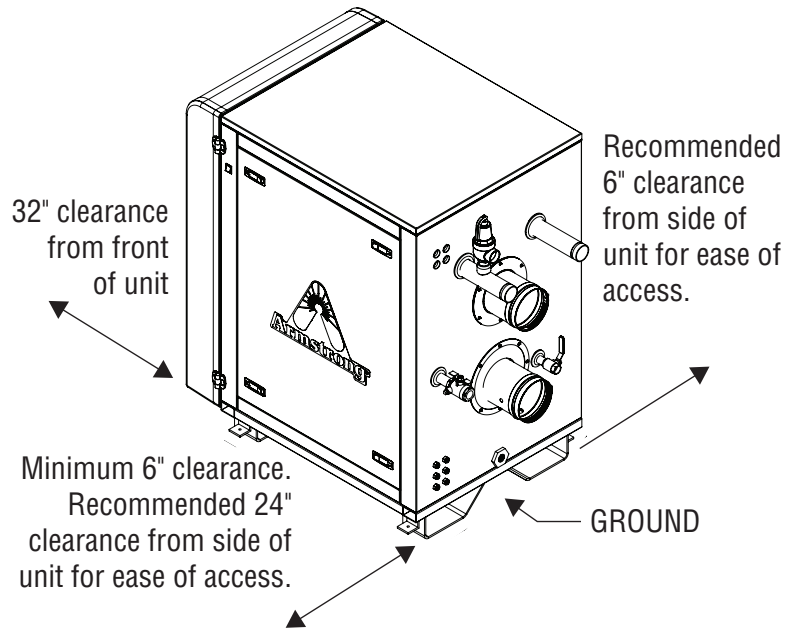

## G. PRE-INSTALLATION REQUIREMENTS

The appliance models 800–1500 are designed to be installed using a factory designed and supplied rack or frame. It can be installed in alcoves, basements, and utility rooms, as well as standard equipment rooms. Choose a location for your appliance, centralized to the piping system, along with consideration for Electrical (Part 2), Gas Connection (Part 3), Venting (Part 4), and Condensate Drain (Part 4, Section F) **and temperature (Min/Max Ambient 33–105°F, Max Air Intake 120°F).**

The appliance rack must be level as installed, and the mounting surface must be designed to support the weight (see previous page, Table 1-2 for weights). Be sure the appliance is adequately secured to the mounting surface.

The front cover is secured by a Hex Head Latch. **When removing the front cover of the appliance, you must make sure all electric power to the appliance is turned off.**

If the appliance is set up for use on liquefied petroleum (LP) gas, some geographic areas follow the Uniform Mechanical Code, section 304.6, "Liquefied petroleum gas burning appliances shall not be installed in a pit, basement or similar location where heavier-than-air gas might collect. Appliances so fueled shall not be installed in a below grade under-floor space or basement **unless such location is provided with an approved means for removal of unburned gas.**"

**Note:** A water chemistry analysis should be performed prior to any installation. If the water quality exceeds any of the following levels, then a water chemistry analysis must be performed:

- **Water hardness can be no more than 12 grains (205 ppm or mg/l)**
- **TDS (total dissolved solids) can be no more than 450 ppm or mg/l**
- **PH—below 6.5 or above 7.5**

**For total combined hardness over 15 grains (250 ppm or mg/l) or longer pipe lengths, contact the Manufacturer for correct pump sizing. Combined, the hardness and TDS can be no more than 450 ppm. Our internal term for this is the TCH (Total Combined Hardness).**

## #1 TURN OFF POWER TO UNIT

Turn off power at the breaker supplying power to the appliance. In a factory supplied Cascade package, turn off at the Intermediate Disconnect.

Just turning off the on-off switch on the front of the appliance does not eliminate all power from within the appliance cabinet and electrical shock hazard still exists.



(FIGURE 1-4)

Step 1—  
Turn power off to unit  
at power switch

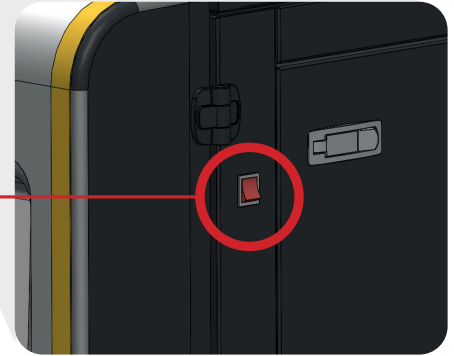

## ⚠️ WARNING

The appliance is certified as an indoor appliance. Do not install outdoors or in unconditioned spaces where it will be exposed to temperatures above or below specified min/max ambient temperatures. This includes all related piping and components. If the appliance is subjected to flood water or submersed in water, the appliance must be replaced.

## ⚠️ NOTICE

Condensation Removal: This is a condensing, high efficiency appliance, therefore condensation removal must be addressed to avoid damage to surrounding area or appliance. See Part 4, Section F for Condensate Requirements.

## H. PRESSURE RELIEF VALVE

## ⚠️ WARNING

Do not, under any circumstances, thread a cap or plug into the relief valve! Explosion, severe personal injury, death, or major property damage may result.

This unit is supplied with a relief valve sized in accordance with ANSI/ASME Heater and Pressure Vessel Code, Section IV. The relief valve is installed near the hot water outlet. If the valve supplied is replaced, the pressure rating of the valve must not exceed the listed working pressure of this appliance, and must be rated to the proper BTU/hr capacity of the water heater. **Do not, under any circumstances, thread a cap or plug into the relief**

**valve! Explosion, serious injury or death may result!** To prevent water damage, the relief valve piping must be directed to the floor or an open drain, but not connected directly. There must be a 6" space between the outlet of relief valve piping and drain or floor. Do not hook up to drain system directly without an air gap. Protect from freezing. Place no other valve between the relief valve and the unit. Do not install any reducing couplings or other restrictions in the discharge line. The discharge line must allow complete drainage of the valve and line. Manually operate the relief valve at least once a year.

Also, care must be exercised when choosing the location of this

appliance, where leakage from the relief valve, leakage from related piping, or leakage from the tank or connections, will not result in damage to the surrounding areas, or to the lower floors of the building. A water heating appliance should always be located in an area with a floor drain or installed in a drain pan suitable for water heating appliances. Under no circumstances, shall the Manufacturer be held liable for any such water damage whatsoever.

## PART 2. ELECTRICAL

### A. ELECTRICAL CONNECTION / REQUIREMENTS

The electrical connection for the appliance is on the back of the unit. There is a 1/2" knockout location for an electrical connection for the appliance's incoming power connection. All electrical wiring must be performed by a qualified licensed electrician in accordance with National Electrical Code ANSI/NFPA and/or the Canadian Electrical Code, Part 1 CSA C22.1, or to any applicable local codes and standards. For your convenience, all the points for electrical connections needed to operate the appliance are labeled.

**NOTE: Always check electrical ground to known earth ground; if less than 0.5 ohms, ground is sufficient (meter MUST be on lowest setting).**

We recommend a simplified test, differing from one looking for building earth ground issues, it is our intent to use this test as an indicator

of equipment room electrical grounding issues, or equipment bonding issues, not prove the earth ground to the building.

Take an Ohm meter and place one lead on a known earth ground (not the ground wire on the appliance), and place the other lead on 1) The near appliance system piping, 2) The appliance heat exchanger, or 3) The appliance cabinet.

If any of those readings exceed 0.5 Ohms, then it is a good indicator that there may be sufficient stray current flowing through the water in the piping system to accelerate or amplify conditions that can cause pump, appliance or piping issues in the not too distant future.

**If any readings are over 0.5 ohms, an electrician should be brought in to correct the problem.**

The electrical requirements are for standard 208–240 volt split phase, 50/60 Hz 15 Amp service. When the unit is first powered on, there is a self-setting of the electronics for 50 Hz or 60 Hz. At every power up, the electronics will take a couple of seconds to compare the pulses of the power to the pulses of the crystal, which is built into the electronics. Then all time-related functions are correct no matter the power source.

The standard supplied pumps are all 208–240 VAC, 60 cycle and are to be wired to terminals indicated on the appliance. In 50 cycle applications, other pumps may need to be supplied, depending on water conditions.

### B. INTERNAL WIRING CONNECTION

#### CAUTION

The incoming power shall be connected directly to the labeled, intended connection points only. Failure to do so may result in an electrical short and the control board will have to be replaced!

#### DANGER

It is extremely important that this unit be properly grounded! It is very important that the building ground is inspected by a qualified electrician prior to making this connection!

Failure to confirm proper grounding and the absence of stray voltage may result in premature component failure. See start up and commissioning documents (*DXXXXXX–Start Up Checklist*) for details.

Terminal G (see Appendix) in the electrical compartment must be connected to the building ground system.

The incoming 208–240 volt split phase power supply is connected to terminals L1, L2, N and ground, see drawings in Part 2, Section B.

It is important that the electrical power is not turned on at this time. Double check all connections and then turn the power on. The display that is provided with the appliance should now be reading the Setpoint temperature.

**NOTE: See Start-Up Procedures (Part 6, Section D) to change the temperature setting or run the appliance.**

# B. INTERNAL WIRING CONNECTION (continued)

## XL-BCB LAYOUT

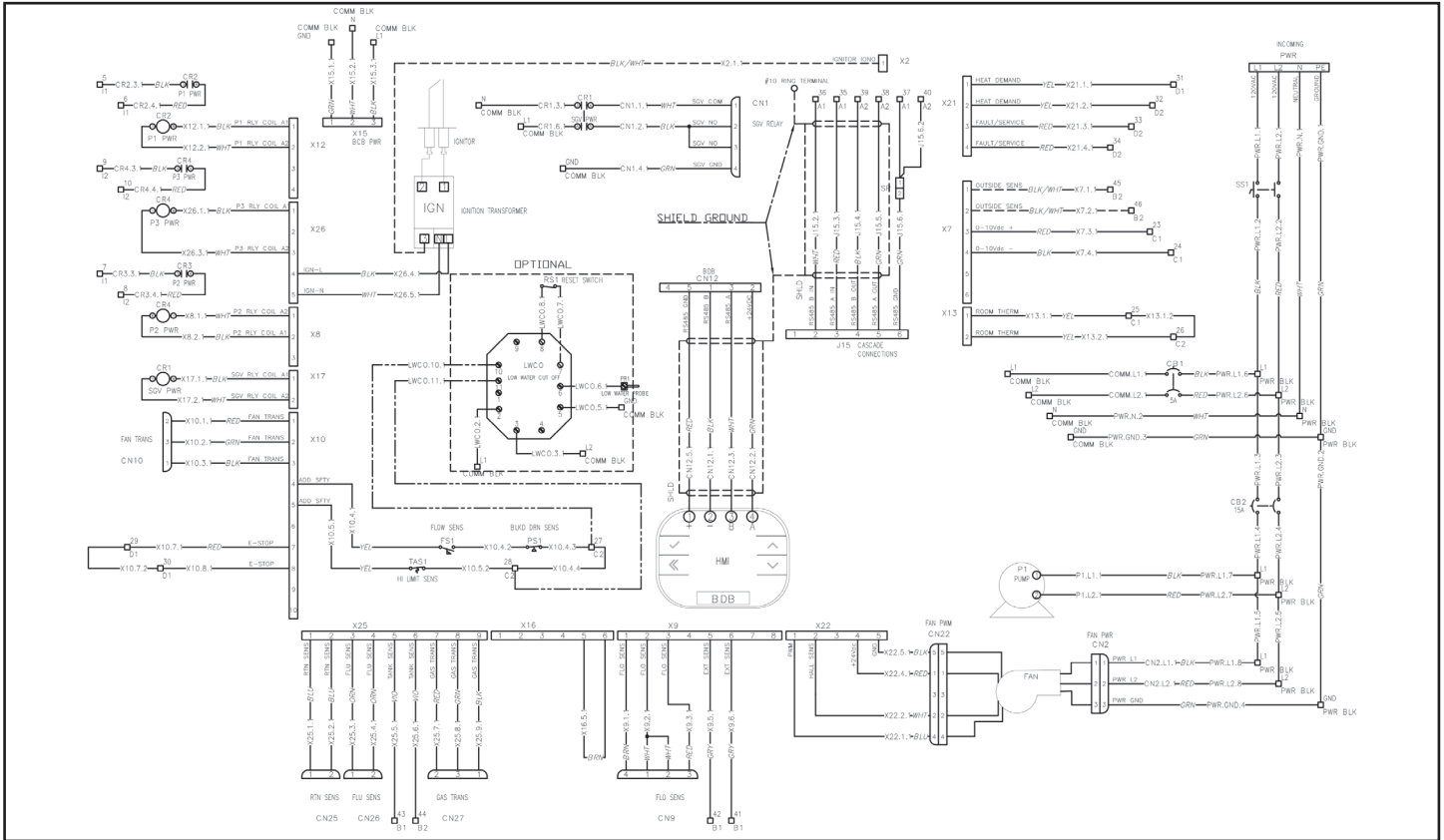

## B. INTERNAL WIRING CONNECTION (continued)

### (FIGURE 2-1) .2 FIELD WIRING CONNECTIONS

- A. Terminals 1 & 2  
External Sensor Connection (T6)  
— System temperature sensor, senses water temp in a heating loop.
- B. Terminals 3 & 4  
Outdoor Sensor (T4) — Outdoor air sensor, set point will adjust based on outdoor air temperature (not needed if 0-10 VDC output is connected)
- C. Terminals 5 & 6  
0-10 VDC — Connect a 0-10 VDC output here to vary set point temperature. Requires a connection to each appliance.
- D. Terminals 7 & 8  
Fault Service — Alarm bell or light may be connected here to indicate that the appliance is a hard lockout.
- E. Terminals 9 & 10  
Additional Heat Demand — dry contacts that will close a thermostat on an extra appliance if the appliance is at 100% of capacity.
- F. Terminals 11 & 12  
Room Thermostat — Normally jumped. A room thermostat may be connected here to enable/disable the appliance.
- G. Terminal 13-17  
Cascade Connection — Communication cables get connected here and “daisy chained” to all appliances in a cascade. This is polarity sensitive.
- H. Terminals 18 & 19  
Tank Sensor (T3) — Sensor for indirect or direct DHW. An aquastat may also be connected here.  
Terminals 20 & 21  
Additional Safety Circuit. On .3 models, it contains the Water Flow Switch; the burner door and rear wall high limits in series.
- I. Terminals 22 & 23  
E-stop—Requires a parallel wiring connection between appliances back to E-stop switch at rom wall.

**XL-CASCADE BOX**

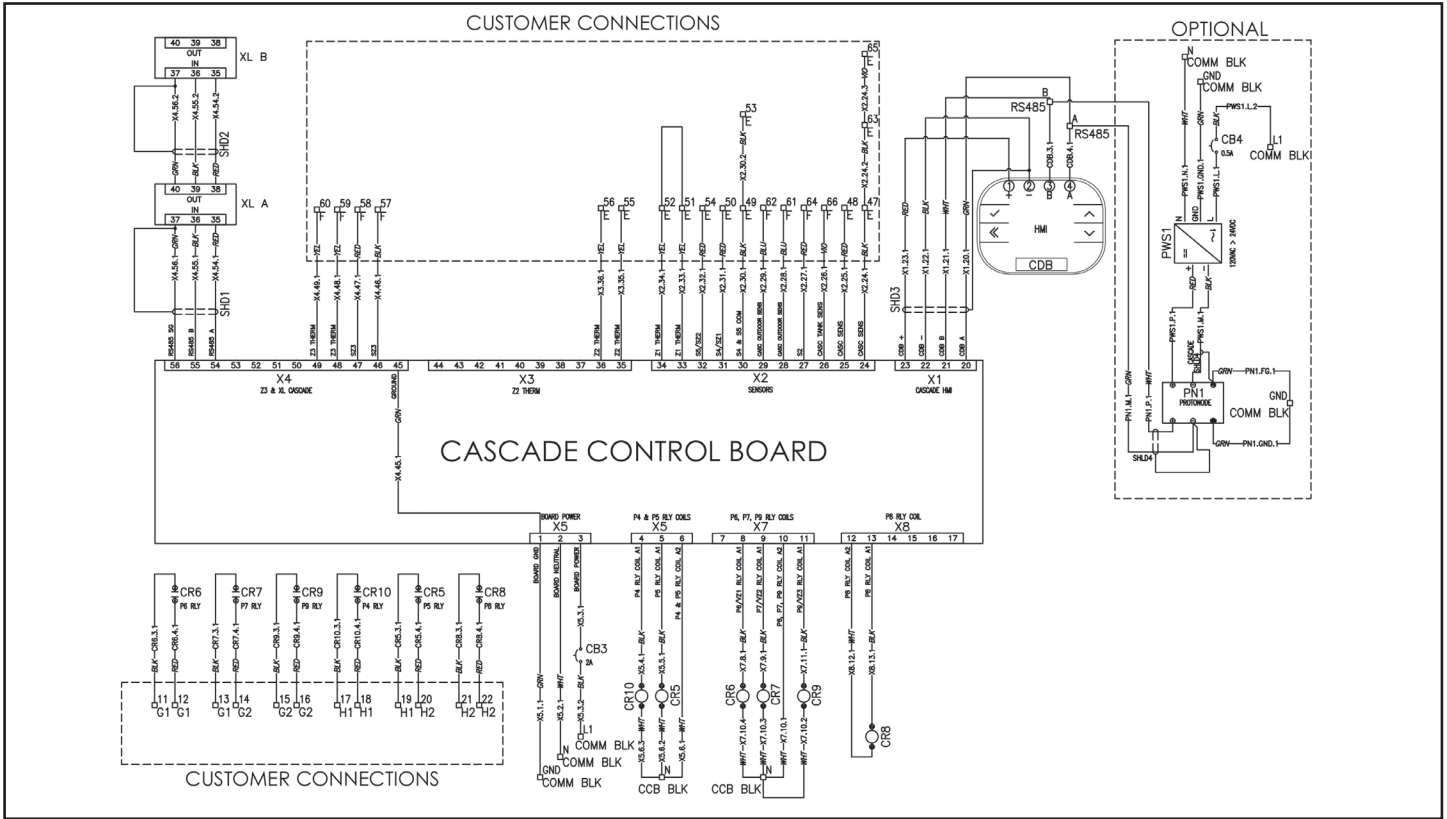

Parameter CCS1	System Description	Outputs Controlled					Switches			Sensors/input signals						
		P4 - CCB 4, 6	P5 - CCB 5, 6	P6 - CCB 8, 10	P7 - CCB 9, 10	P8 - CCB 12, 13	P9/VZ3 - CCB 10, 11	Enable / Disable CCB 33, 34	Enable / Disable CCB 35, 36	Enable / Disable CCB 48, 49	S1 - CCB 24, 25	S2 - CCB 24, 27	S3 - CCB 24, 26	S4 - CCB 30, 31	S5 - CCB 30, 32	S7/SZ3 CCB 46, 47
0	Heating only (CH)	x		x	x		x	x	x	x			x	x	x	x
1	Heating with Indirect Hot Water and Recirculation		x	x	x	x	x	x	x	x	x		x	x	x	x
2	Direct Hot Water and Recirculation					x					x		x			
3	Indirect Hot Water and Recirculation		x			x		x	x	x	x					
4	iPool			x			x			x			x			
5	ISPA				x			x		x				x		
6	iPool and ISPA	x	x	x	x		x	x		x			x	x		
7	One Heating zone and iPool	x		x			x		x	x			x		x	x
8	One Heating zone and ISPA		x		x			x	x	x				x	x	x
9	One Heating zone and iPool and ISPA	x	x	x	x		x	x	x	x			x	x	x	x
10	iDHW and iPool and Recirculation	x		x		x	x			x	x	x	x			
11	iDHW and ISPA and Recirculation		x		x	x	x		x	x			x		x	
12	iDHW and iPool and ISPA and Recirculation	x	x	x	x	x	x	x		x	x	x	x	x		

## PART 3. GAS CONNECTION

### A. GAS CONNECTION AND INSPECTION

#### DANGER

**FAILURE TO FOLLOW ALL PRECAUTIONS COULD RESULT IN FIRE, EXPLOSION OR DEATH!**

**When attaching the gas line to the boiler hold the gas pipe on the boiler so it is not permitted to rotate while tightening the gas line.**

The gas supply shall have a maximum inlet pressure of less than 1/4" water column (1/2 PSI) (3.44 kPa), and a minimum of 4" water column. The entire piping system, gas meter and regulator must be sized properly to prevent pressure drop greater than 1" as stated in the National Fuel Gas Code. This information is listed on the rating plate. **It is very important that you are connected to the type of gas as noted on the rating plate, "LP"** for liquefied petroleum, propane

### B. GAS PIPING

The gas piping must be sized for the proper flow and length of pipe, to avoid pressure drop. Both the gas meter and the gas regulator must be properly sized for the total gas load. If you experience a pressure drop greater than 1" WC, the meter, regulator or gas line is undersized or in need of service. You can attach a manometer to the 1/4" NPT port provided on the gas cock. Alternatively, you can attach the manometer to the incoming gas drip leg, by removing the cap and installing the manometer. The gas pressure must remain

gas or "Nat" for natural or city gas. All gas connections must be approved by the local gas supplier, or utility in addition to the governing authority, prior to turning the gas supply on. It is mandatory that a drip leg be fabricated, as per the National Fuel Gas code. Once all the inspections have been performed, the piping must be leak tested. It is recommended that a soapy solution be used to detect leaks. Bubbles will appear on the pipe to indicate a leak is present. If the leak test requirement is a higher test pressure than the maximum inlet pressure, you must isolate the appliance from the gas line. In order to do this, you must shut the gas off using factory and field-installed gas cocks (following the lighting instructions in Part 6, Section B) This will prevent

between 4" and 1/4" during stand-by (static) mode and while in operating (dynamic) mode. **If an in-line regulator is used, it must be a minimum of 10 equivalent feet from the appliance. It is very important that the gas line is properly purged by the gas supplier or utility. Failure to properly purge the lines or improper line sizing, will result in ignition failure.** This problem is especially noticeable in NEW LP installations and also in empty tank situations. This can also occur when a utility company shuts off service

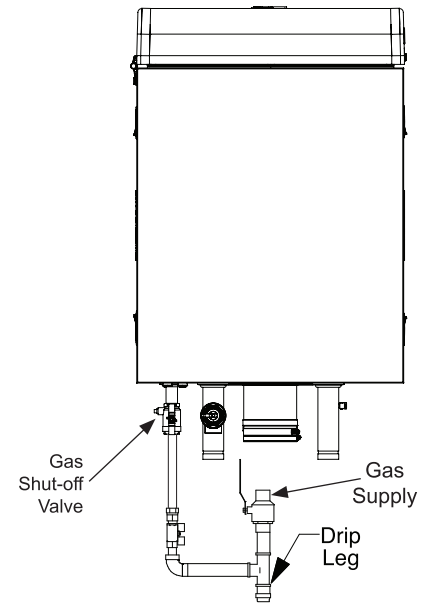

**(FIGURE 3-1) APPLIANCE GAS CONNECTION**

high pressure from reaching the valve. Failure to do so may damage the gas valve.

**Never use an open flame (match, lighter, etc.) to check gas connections.**

to an area to provide maintenance to their lines. This gas valve must not be replaced with a conventional gas valve under any circumstances. As an additional safety feature, this gas valve is easily de-coupled from the fan inlet.

**Refer to the following tables to size the supply piping to minimize pressure drop between meter or regulator and unit.**

**C. GAS TABLES**

**(TABLE 3-1) NATURAL GAS SUPPLY PIPING**

Nominal Iron Pipe Size (in)	Internal Diameter Inches	Length in Pipe (feet)													BTUs per HR x 1,000
		10	20	30	40	50	60	70	80	90	100	125	150	200	
3/4	0.824	363	249	200	171	152	138	127	118	111	104	93	84	72 }	
1	1.049	684	470	377	323	286	259	239	222	208	197	174	158	135 }	
1-1/4	1.380	1,404	965	775	663	588	532	490	456	428	404	358	324	278 }	
1-1/2	1.610	2,103	1,445	1,161	993	880	798	734	683	641	605	536	486	419 }	
2	2.067	4,050	2,784	2,235	1,913	1,696	1,536	1,413	1,315	1,234	1,165	1,033	936	801 }	

(Based on 0.60 specific gravity for natural gas at 0.5" WC pressure drop; DOE standard is 1100 BTU per cubic foot of natural gas.)

1. Run the gas supply line in accordance with all applicable codes.
2. Locate and install manual shut off valves in accordance with state and local requirements.

Nominal Iron Pipe Size (DN)	Outer Diameter mm	Length in Pipe (meters)													BTUs per HR x 1,000
		3.05	6.1	9.1	12.2	15.2	18.3	21.3	24.4	27.4	30.5	38.1	45.7	60.96	
20	26.67	110.6	75.9	60.96	52.1	46.3	42.1	38.7	35.96	33.8	31.7	28.3	25.6	21.9	
25	33.4	208.5	143.2	114.9	98.45	81.2	78.94	72.8	67.66	63.4	60.04	53.03	48.16	41.15	
32	42.16	427.94	294.13	236.22	202.08	179.22	162.15	149.35	138.99	130.45	123.14	109.12	98.75	84.73	
40	48.26	640.99	440.43	353.87	302.66	268.22	243.23	223.72	208.18	195.37	184.4	163.37	148.13	127.71	
50	60.33	1234.44	848.56	681.23	583.08	516.94	468.17	430.68	400.81	376.12	355.09	314.86	285.29	244.14	

**(TABLE 3-2) PROPANE SUPPLY PIPING (BASED ON 11" WC SUPPLY PRESSURE)**

Nominal Iron Pipe Size (in)	Internal Diameter Inches	Length in Pipe (feet)													BTUs per HR x 1,000
		10	20	30	40	50	60	70	80	90	100	125	150	200	
3/4	0.824	567	393	315	267	237	217	196	185	173	162	146	132	112 }	
1	1.049	1,071	732	590	504	448	409	378	346	322	307	275	352	213 }	
1-1/4	1.380	2,205	1,496	1,212	1,039	913	834	771	724	677	630	567	511	440 }	
1-1/2	1.610	3,307	2,299	1,858	1,559	1,417	1,275	1,181	1,086	1,023	976	866	787	675 }	
2	2.067	6,221	4,331	3,465	2,992	2,646	2,394	2,205	2,047	1,921	1,811	1,606	1,496	1,260 }	

Nominal Iron Pipe Size (DN)	Outer Diameter mm	Length in Pipe (meters)													BTUs per HR x 1,000
		3.05	6.1	9.1	12.2	15.2	18.3	21.3	24.4	27.4	30.5	38.1	45.7	60.96	
20	26.67	172.82	119.78	96.01	81.38	72.24	66.14	59.74	56.39	52.73	49.38	44.5	40.23	34.14	
25	33.4	326.44	223.11	179.83	153.62	136.55	124.66	115.21	105.46	98.15	93.57	83.82	107.29	64.92	
32	42.16	672.08	455.98	369.42	316.69	278.28	254.2	235	220.67	206.35	192.02	172.82	155.75	134.11	
40	48.26	1007.97	700.73	566.32	475.18	431.9	388.62	359.97	331.01	311.81	297.48	263.96	239.88	205.74	
50	60.33	1896.16	1320.09	1056.13	911.96	806.5	729.69	672.08	623.93	585.52	551.99	489.51	455.98	384.05	

## D. GAS VALVE SETUP

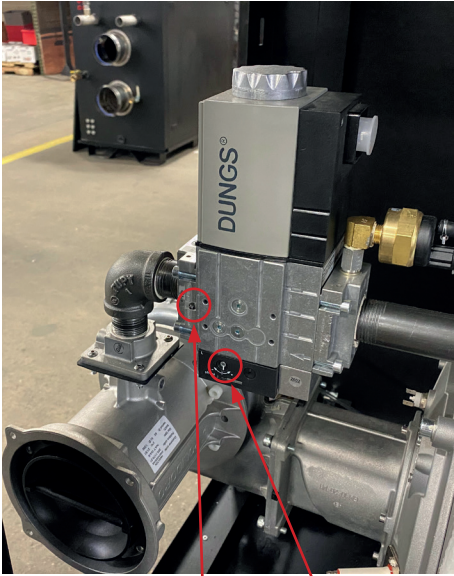

(FIGURE 3-2)

Low Fire Adjustment

High Fire Adjustment

### Please see Part 6—Start-Up Procedures before continuing!

Proper gas volume and pressure is critical to the operation of any high efficiency appliance. There are three types of measurements that must be taken to provide the data to insure product performance:

- Lock-up pressure (pressure in gas piping at appliance inlet with no load) may not exceed 14" wc. at any time!
- Minimum load at ignition of a single unit in a multiple unit rack
- Maximum load—all appliances on at full fire that are being tested and any other gas fired equipment on the same gas supply.
- Gas pressure for minimum load should be measured the moment after the gas valve opens on a single appliance, and recorded.
- Gas pressure for maximum load shall be measured with all units on at full fire and all other connected loads on that gas supply running
- Gas pressure drop shall not exceed 1" wc. between minimum load and maximum load as described above.

**NOTE:** Inlet gas pressure at the gas valve, may also be read on the BDB (Display screen) under the STATUS screen during all operations.

### How and where to measure:

- All gas pressure tests must be taken at the gas manifold inlet, external to the appliance (see diagram).

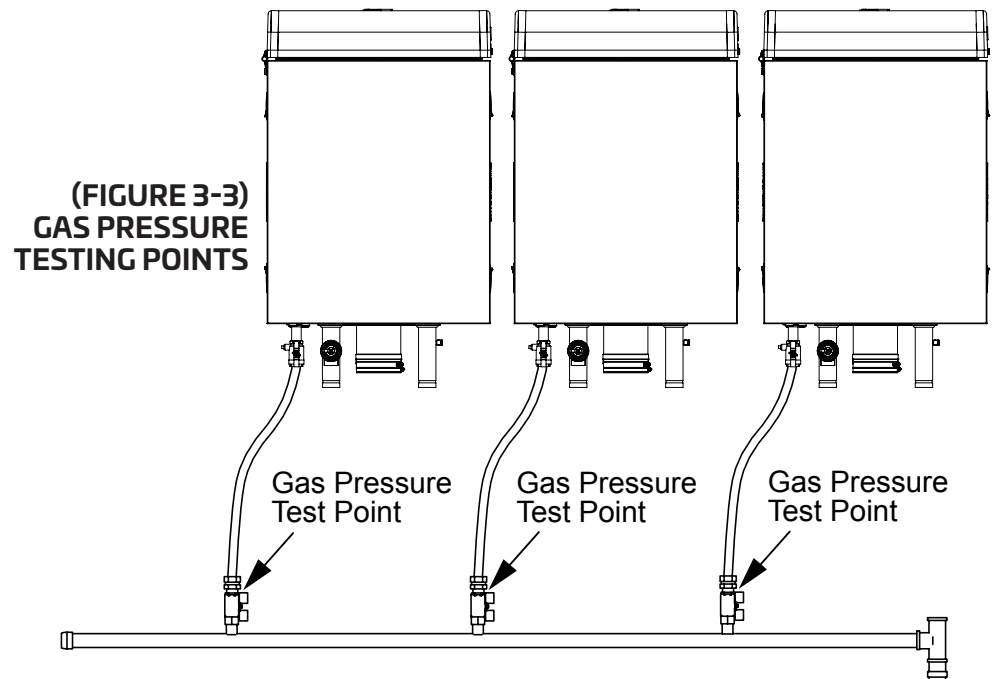

**(TABLE 3-3) COMBUSTION & FUEL RELATED ADJUSTMENT TABLE**

	Natural Gas CO <sub>2</sub>		Natural Gas CO ppm	LP Gas CO <sub>2</sub>		LP Gas CO ppm
	Door Closed	Door Open	Approximate, do not use for setup!	Door Closed	Door Open	Approximate, do not use for setup!
LOW FIRE	8.30%		Less than 10	9.60%		Less than 10
HIGH FIRE	8.80%		Less than 100	10.20%		Less than 120

**PLEASE NOTE: All adjustments must be made with the appliance door off, which will lower the CO<sub>2</sub> reading 0.2%.** See tables above for specific readings.

When checking or replacing a gas valve, the CO<sub>2</sub> percentage in the flue gas is the preferred measuring method to insure proper combustion and firing rate. CO is used as the (temporary) alternate.

Changing incoming air temperature may vary the CO<sub>2</sub> setting slightly (~0.2–0.6%) after initial set up. This is not cause for concern or reason to set up again. After one year of operation, set up is required again.

If your appliance will be operated in an area that has inlet air temperature variations greater than 80°F, please use the following table in adjusting your CO<sub>2</sub> for optimum performance.

**(TABLE 3-4) CO<sub>2</sub> ADJUSTMENT TABLE**

Inlet air ΔT variation	Setup at minimum incoming air temperature	Setup at maximum incoming air temperature
80°F (26.67°C)	Reduce CO <sub>2</sub> 0.2%	Increase CO <sub>2</sub> 0.2%
100°F (37.78°C)	Reduce CO <sub>2</sub> 0.3%	Increase CO <sub>2</sub> 0.3%
120°F (48.89°C)	Reduce CO <sub>2</sub> 0.4%	Increase CO <sub>2</sub> 0.4%

## E. SETTING THE MAXIMUM LOAD

A means of sampling the leaving flue gas is built into the vent connector on top of the appliance. Remove the rubber plug for testing and replace when testing is completed. This plug **MUST** be in place during normal operation.

Enter the service function (reference the Control Section for instructions) from the setup menu. After the

service function is active, fan speed percentage can be set. This should be set to 100% to achieve maximum fan speed for high fire combustion setting.

If necessary, turn the adjusting slot [1], which sets the high fire performance, according to the markings on the gas valve, to increase or decrease the CO<sub>2</sub>

percentage, as shown in **Figure 3-2**, Part 3, Section D. Appropriate CO<sub>2</sub> percentages are shown in **Table 3-3** above.

**NOTE:** If the system is a common vented cascade, there are specific instructions related to proper combustion setting (see Part 6, Section B for details).

**(TABLE 3-5) FAN SPEED REQUIREMENTS**

HW 800		
Fan Type	Maximum RPM	Minimum RPM
Ametek 8.9 High Output Enhanced +	8300	2739

HW 1000		
Fan Type	Maximum RPM	Minimum RPM
Ametek 8.9 High Output Enhanced +	8800	2728

HW 1500		
Fan Type	Maximum RPM	Minimum RPM
Ametek 8.9 High Output Enhanced +	10400	2496

## F. SETTING THE MINIMUM LOAD

Set the minimum load once the maximum load has been set, set the fan speed in the service function to the minimum RPM setting. In order to set or adjust the minimum load, turn the screw [2] for the minimum setting. Turn the screw according to the markings on the gas valve, to increase or decrease the CO<sub>2</sub> percentage.

- If the measuring process takes more than 40 minutes, the appliance will return to the automatic mode. If so required, enter the Service function another time.
- When you are done setting the valve, press stop in the Service function to return to normal run mode.

## G. GAS CONVERSION

If the appliance is to be converted in the field for using Propane (LPG), the following steps must be taken:

- Turn screw [1] clockwise (Figure **3-2**, Part 3, Section D)  $\frac{3}{4}$  of one turn (270°) on models 299 and 1 full turn (360°) on model HW399
- On model HW599 turn screw on left hand valve closed (clockwise)
- and turn right valve  $1\text{-}\frac{3}{4}$  of a full turn clockwise.
- Run the appliance. If the burner does not ignite after four starting efforts, turn the screw [1] one half turn back (180°) (counter clockwise).
- After conversion, follow the steps in Sections E and F for setting the

maximum and minimum loads, using the LP gas values shown in Table **3-3**, Part 3, Section D.

## PART 4. VENTING

### A. APPROVED VENTING MATERIALS

ALL VENT PIPE MATERIALS AND FITTINGS MUST COMPLY WITH THE FOLLOWING:			
Item	Material	Standards for installation in:	
		United States	Canada
Vent pipe and fittings	AL 29-4C Stainless	ANSI/ASTM UL1738	UL1738
	PVC schedule 40*	ANSI/ASTM D1785	CPVC and PVC venting must be ULC-S636 Certified. IPEX is an approved vent manufacturer in Canada supplying vent material listed to ULC-S636.
	CPVC schedule 40	ANSI/ASTM F441	
	Polypropylene (PP)	ULC-S636	ULC-S636
Pipe cement & primer	PVC	ANSI/ASTM D2564	IPEX System 636 Cements & Primers
	CPVC	ANSI/ASTM F493	

**NOTICE: DO NOT USE CELLULAR (FOAM) CORE PIPE**

Please note: Venting system may contain one or more of the above materials.

**The appliance is a direct vent appliance and is listed as a Category IV condensing appliance. (The appliance Venting is rated at Zero Clearance to combustibles.)**



### SPECIAL VENTING SYSTEM DESIGN NOTES

THE APPLIANCE EFFICIENCY TESTING AND RATINGS ARE BASED ON A SEALED, TWO PIPE VENT SYSTEM; HOWEVER, MANY OTHER VENT CONFIGURATIONS ARE AVAILABLE AS FACTORY ENGINEERED SOLUTIONS. PLEASE CONTACT THE FACTORY IF EXCEPTIONS ARE REQUIRED FOR YOUR INSTALLATION.



### DANGER

It is extremely important to follow these venting instructions carefully. Failure to do so can cause severe personal injury, death or substantial property damage.



### WARNING

This vent system will operate with a positive pressure in the vent pipe. Do not connect vent connectors serving appliances by natural draft into any portion of mechanical draft systems operating under pressure.

**NOTE: If set points exceed 140°F (60°C), use of PVC is NOT recommended, even though product is approved as such. Contact the Manufacturer for further clarification.**

## B. VENTING THE APPLIANCE

**(TABLE 4-1) VENTING SPECIFICATIONS**

Model	Vent Diameter	Standard Vent Type	Optional Vent Type	Minimum Combined Vent Length	Maximum Combined Length
HW 800	6" (152mm)	Stainless	Plastic	6' (1.8M) + (2) 90° elbows	240' (73.2M)
HW 1000	6" (152mm)	Stainless	Plastic	6' (1.8M) + (2) 90° elbows	180' (54.9M)
HW 1500	8" (203mm)	Stainless	Plastic	6' (1.8M) + (2) 90° elbows	400' (121.9M)

\*The use of 6" PVC will require the purchase of a special adapter from the Manufacturer.

**(TABLE 4-2) EQUIVALENT FEET**

Fittings or Piping	Equivalent Feet/M
90 degree elbow	5' (1.5M)
45 degree elbow	3' (0.9M)
Coupling	0 (0M)
Air inlet elbow	6' (1.8M)
Exhaust coupling	1' (0.3M)

The inlet and exhaust pipes on the back of the cabinet should be the diameter and material indicated in the Venting Specifications Table above. It is very important that you plan the location properly to eliminate long pipe runs and excessive fittings. Inlet pipe size must not be reduced. *Do not combine the inlet air or exhaust with any other inlet or exhaust pipe including either to an additional similar appliance, unless you have purchased an engineered Common Venting System from the Manufacturer.* The joints must be properly cleaned, primed and cemented if plastic, and sealed per the manufacturer's instructions if stainless. The piping must also be properly supported as per Local and National Standard Plumbing Codes. It is important that the piping must be clean and free from burrs, debris, ragged ends and particles of PVC (if applicable).

**NOTE:** Cascaded system may be supplied with a factory designed and assembled common vented exhaust and intake air system, those maximum lengths are determined by factory engineers on a per project basis.

**Use of common venting systems not supplied by the appliance manufacturer will void certifications and warranty.**

## B. VENTING THE APPLIANCE (continued)

Exhaust piping should be sloped back to the connection on the appliance, at least  $\frac{1}{4}$ " per foot (PP piping above 5" diameter requires  $\frac{5}{8}$ " per foot) to remove additional condensate that forms within the pipe. The total combined length of pipe (intake piping plus exhaust piping added together) including elbow allowances intake and exhaust should not exceed the length shown in the vent table. The minimum combined vent length should not be less than a combined length of

6' plus two 90° elbows. Choose your vent termination locations carefully. You must also make certain that exhaust gas does not re-circulate back into the intake pipe. You must place them in an open area and follow the following guidelines:

### NOTICE

**The following are code restrictions for the location of the flue gas vent terminal. Compliance to these requirements doesn't insure a satisfactory installation; good common sense must also be applied. It is important to make sure that exhaust gases are not recirculated into the inlet air of the appliance. If there is any doubt, contact the factory BEFORE installing.**

## EXISTING COMMON VENT SYSTEMS

If an existing appliance is removed from a common venting system, the common venting system may then be too large for the proper venting of the remaining appliances connected to it. At the time of removal of an existing appliance, the following steps shall be followed with each appliance remaining connected to the common venting system placed in operation, while the other appliances remaining connected to the common venting system are not in operation.

- a) Seal any unused openings in the common venting system.
- b) Visually inspect the venting system for proper size and horizontal pitch and determine there is no blockage or restriction, leakage, corrosion and other deficiencies which could cause an unsafe condition.
- c) Insofar as is practical, close all building doors and windows and all doors between the space in which the appliances remaining connected to the common venting system are located and other spaces of the building. Turn on clothes dryers and any appliance not connected to the common venting system. Turn on any exhaust fans, such as range hoods and bathroom exhaust, so they will operate at maximum speed. Do not operate a summer exhaust fan for an appliance installation. Close fireplace dampers.
- d) Place in operation the appliance being inspected. Follow the lighting instructions. Adjust thermostat so appliance will operate continuously.
- e) After it has been determined that each appliance remaining connected to the common venting system properly vents when tested as outlined above, return doors, windows, exhaust fans, fireplace dampers and any other gas-burning appliance to their previous condition of use.
- f) Any improper operation of the common venting system should be corrected so the installation conforms with the National Fuel Gas Code, ANSI Z223.1/NFPA 54. When resizing any portion of the common venting system, the common venting system should be resized to approach the minimum size as determined using the appropriate tables in Appendix F in the National Fuel Gas Code, ANSI Z223.1/ NFPA 54 and or CSA B149 Installation Codes.



### Direct Vent Terminal Clearances (continued)

K -	Clearance to a mechanical air supply inlet	6 ft (1.83 m)	3 ft (91 cm) above if within 10 ft (3 m) horizontally
L -	Clearance above paved sidewalk or paved driveway located on public property	7 ft (2.13 m)†	Vents for Category II and IV appliances cannot be located above public walkways or other areas where condensate or vapor can cause a nuisance or hazard
M -	Clearance under veranda, porch, deck, or balcony	12 in (30 cm)‡	Per local installation codes
†	A vent shall not terminate directly above a sidewalk or paved driveway that is located between two single family dwellings and serves both dwellings.		
‡	Permitted only if veranda, porch, deck, or balcony is fully open on a minimum of two sides beneath the floor.		
<b>NOTES:</b>			
1)	In accordance with the current CSA B149.1, Natural Gas and Propane Installation Code		
2)	In accordance with the current ANSI Z223.1/NFPA 54, National Fuel Gas Code		
3)	If locally adopted installation codes specify clearances different than those illustrated, then the most stringent clearances must prevail.		

### Other Than Direct Vent Terminal Clearances

		Canadian Installations <sup>1</sup>	US Installations <sup>2</sup>
A -	Clearance above grade, veranda, porch, deck, or balcony	12 in (30 cm)	12 in (30 cm)
B -	Clearance to window or door that may be opened	6 in (15 cm) for appliances $\leq$ 10,000 Btuh (3 kW); 12 in (30 cm) for appliances > 10,000 Btuh (3 kW) and $\leq$ 100,000 Btuh (30 kW); 36 in (91 cm) for appliances > 100,000 Btuh (30 kW)	4 ft (1.2 m) below or to side of opening; 1 ft (300 mm) above opening
C -	Clearance to permanently closed window	Per local installation codes	
D -	Vertical clearance to ventilated soffit located above the terminal within a horizontal distance of 2 ft (61 cm) from the center line of the terminal		
E -	Clearance to unventilated soffit		
F -	Clearance to outside corner		
G -	Clearance to inside corner		
H -	Clearance to each side of center line extended above meter/regulator assembly		
I -	Clearance to service regulator vent outlet	3 ft (91 cm)	
J -	Clearance to nonmechanical air supply inlet to building or the combustion air inlet to any other appliance	6 in (15 cm) for appliances $\leq$ 10,000 Btuh (3kW); 12 in (30 cm) for appliances > 10,000 Btuh (3 kW) and $\leq$ 100,000 Btuh (30 kW); 36 in (91 cm) for appliances > 100,000 Btuh (30 kW)	4 ft (1.2 m) below or to side of opening; 1 ft (300 mm) above opening

## Other Than Direct Vent Terminal Clearances (continued)

K -	Clearance to a mechanical air supply inlet	6 ft (1.83 m)	3 ft (91 cm) above if within 10 ft (3 m) horizontally
L -	Clearance above paved sidewalk or paved driveway located on public property	7 ft (2.13 m)†	Vents for Category II and IV appliances cannot be located above public walkways or other areas where condensate or vapor can cause a nuisance or hazard
M -	Clearance under veranda, porch, deck, or balcony	12 in (30 cm)‡	Per local installation codes
†	A vent shall not terminate directly above a sidewalk or paved driveway that is located between two single family dwellings and serves both dwellings.		
‡	Permitted only if veranda, porch, deck, or balcony is fully open on a minimum of two sides beneath the floor.		
<b>NOTES:</b>			
1)	In accordance with the current CSA B149.1, Natural Gas and Propane Installation Code		
2)	In accordance with the current ANSI Z223.1/NFPA 54, National Fuel Gas Code		
3)	If locally adopted installation codes specify clearances different than those illustrated, then the most stringent clearances must prevail.		

**B. VENTING THE APPLIANCE (continued)**

**(FIGURE 4-2) SIDEWALL VENT WITH DOWN ELBOW (INTAKE) & UP ELBOW (EXHAUST)**

**FOR ALL IMAGES WITH VENTING SHOWN OFFSET FOR CLARITY**

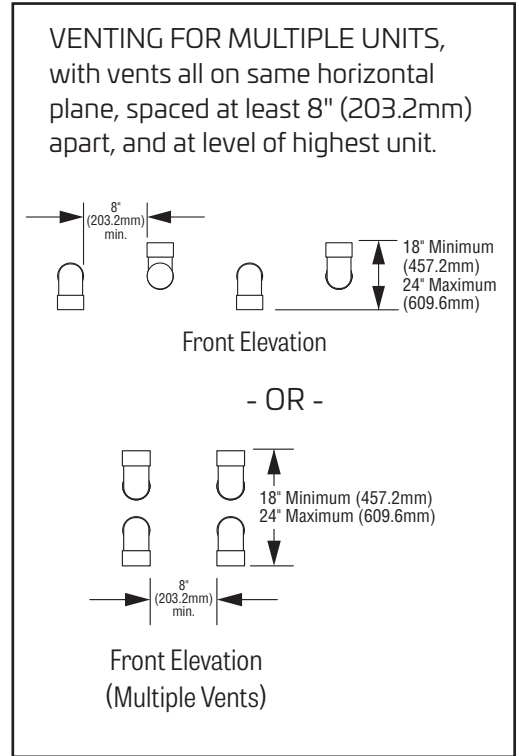
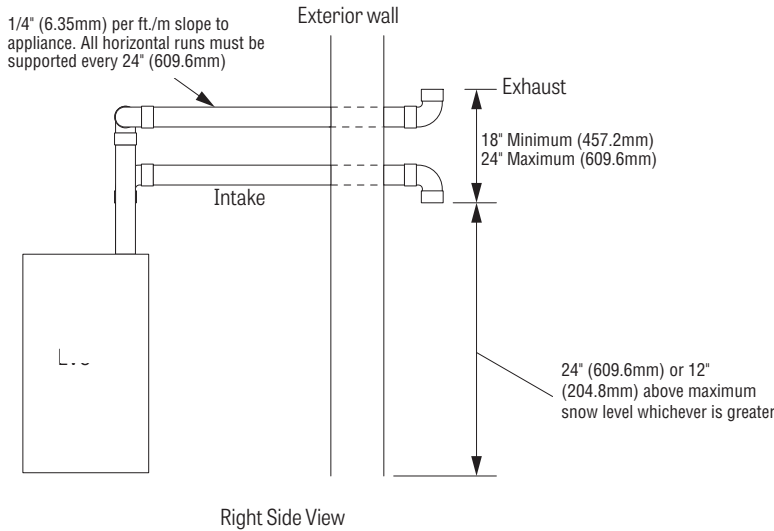

**\*\*IMPORTANT NOTE:** All vent pipes must be glued, properly supported and the exhaust must be pitched a minimum of a 1/4" (6.35mm) per foot/M to the appliance (to allow drainage of condensate). All stainless venting must be sealed at each joint per manufacturer's instructions.

**(FIGURE 4-3) VERTICAL VENT WITH DOUBLE ELBOW (INTAKE) & COUPLING (EXHAUST)**

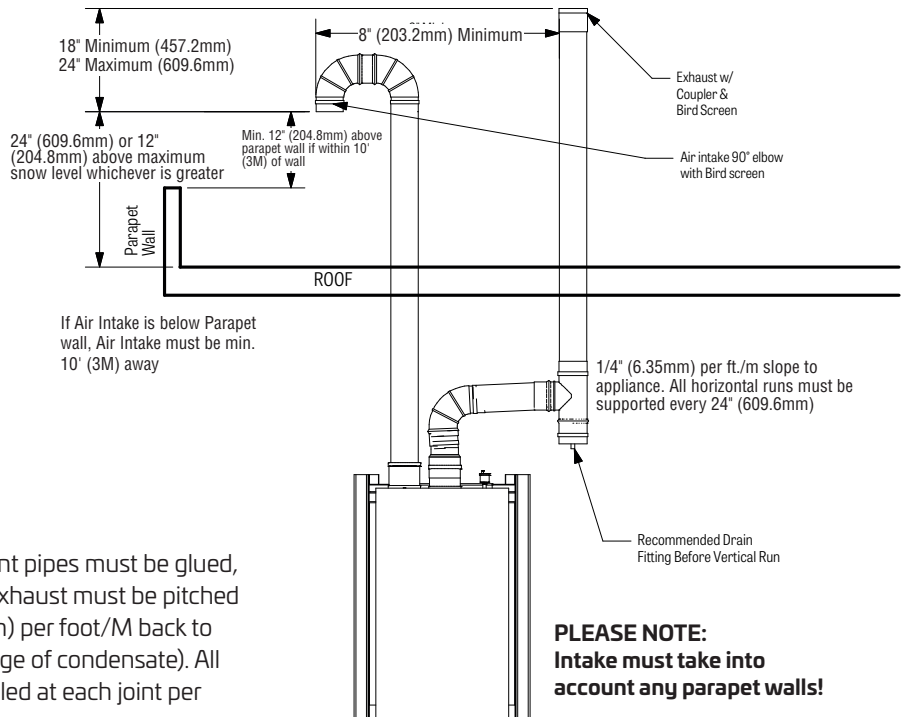

**\*\*IMPORTANT NOTE:** All vent pipes must be glued, properly supported and the exhaust must be pitched a minimum of a 1/4" (6.35mm) per foot/M to the appliance (to allow drainage of condensate). All stainless venting must be sealed at each joint per manufacturer's instructions.

(FIGURE 4-4) VERTICAL VENT WITH PVC/CPVC

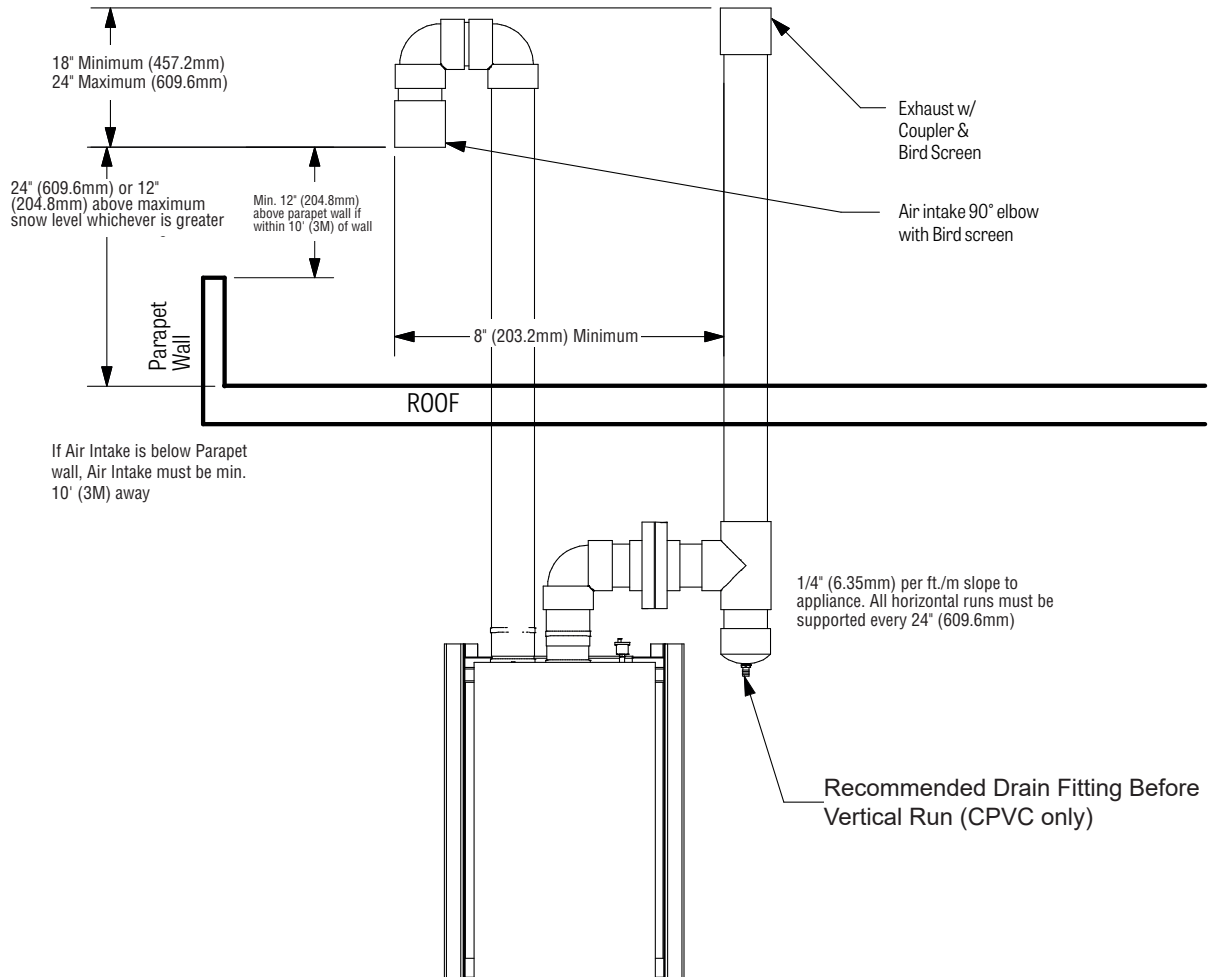

**B. VENTING THE APPLIANCE (continued)**

**DIAGRAMS FOR ROOM AIR VENTING TERMINATION**

If you're using room air, your unit should be set up this way:

**(FIGURE 4-5) VERTICAL TERMINATION**

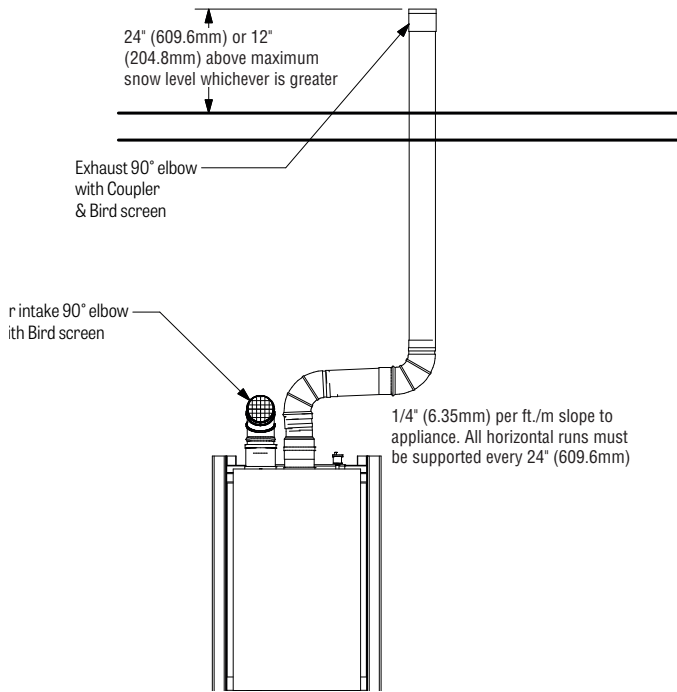

**(FIGURE 4-6) SIDEWALL TERMINATION**

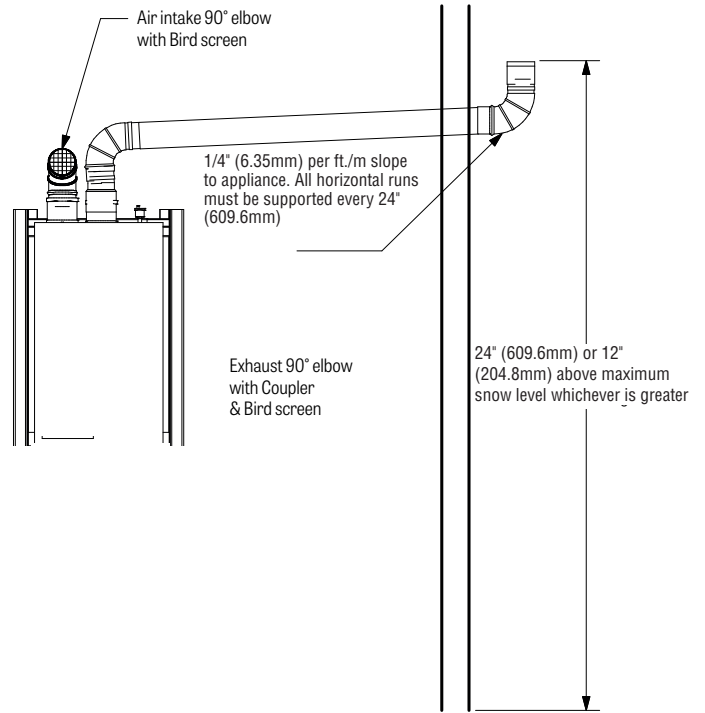

**CAUTION**

Flue Gas will condense as it exits the vent termination. This condensate can freeze on exterior building surfaces which may cause discoloration of these surfaces. Consideration should be given to the plume of condensation that exits the exhaust which may affect the cosmetic appearance of the building.

As long as the boiler room remains under a positive pressure under all operating conditions of the building, this is a perfectly acceptable option. Generally, all this requires is an external free air source; typically just two properly sized openings to the outdoors. Installations done in this manner must comply with ANSI Z223.1, NFPA 54—National Fuel Gas Code 2009 section 9.3, and any specific local codes that may require additional combustion air be provided. For the latest edition, see *Technical Bulletin—TB 003*. This would be our preferred alternate to our standard manual specifications.

**NOTE:** Stated efficiencies are based on ducted air; using room air may effect efficiency.

### C. INLET AIR VENT

You may use the same material as used for exhaust or any material that is the same diameter that provides a pressure tight connection. THIS IS ONLY FOR INLET AIR, NOT FOR EXHAUST PIPING!

The air inlet must be a minimum of 12" (204.8mm) vertically above the maximum snow level. It is very important that there are no other vents, chimneys or air inlets in any direction for at least 48" (1219.2mm).

**All venting must be properly supported. The appliance is not intended to support any venting whatsoever.** All piping, glue, solvents, cleaners, fittings and components, must conform to ASTM (American Society for Testing and Materials), and ANSI (American National Standards Institute).

### D. VENTING RUNS THAT EXCEED MAXIMUM COMBINED LENGTH

***If the combined venting length of an appliance's exhaust/inlet air system exceeds the Maximum Combined Length called out in Part 4, Section A, contact the manufacturer for an engineered venting calculation. Do not proceed without calling the Manufacturer.***

VENT CALCULATION EXAMPLE: Installation requires the following material for both inlet and exhaust piping for the 800 (maximum combined equivalent length is 180 feet).

Required: 8 Pcs. 90° elbow (8 x 5 = 40 equivalent feet) = 40 equivalent feet

Required: 60' of stainless steel pipe (60 x 1 = 60 equivalent feet) = 60 equivalent feet

Required: Inlet air vertical termination (2) 90° elbows + bird screen = 11 equivalent feet

Required: Exhaust birdscreen = 1 equivalent foot

**Total friction loss in equivalent feet = 112 equivalent feet**

***THIS VENT SYSTEM IS OK!***

DANGER

The appliance is not intended to be common vented with any other existing appliance! Multiple appliance products may be common vented, only if using an engineered system by the Manufacturer.

## E. CONDENSATE REQUIREMENTS

This is a condensing high efficiency appliance, therefore this unit has a condensate removal system. Condensate is nothing more than water vapor derived from the combustion products, similar to an automobile when it is initially started. This condensate does have a low pH and should be treated with a Condensate Neutralizer Filter. This filter contains either lime or marble rocks, which will neutralize the condensate. The outlet of the filter is sized for  $\frac{3}{4}$ " hose. ***It is very important that the condensate line is sloped away from and down to a suitable inside drain.*** A condensate neutralizer and a condensate pump kit are available from the Manufacturer. It is also very important that the condensate line is not exposed to freezing temperatures, or any other type of blockage. Plastic tubing or PVC pipe should be the only materials used for the condensate line. Steel, brass, copper or others will be subject to corrosion and deterioration. A second vent may be necessary to prevent condensate line vacuum lock if a long horizontal run is used. The appliance has an automatic safety device that will shut it down in the event of a condensate drain blockage. Please test annually.

Maximum volume of condensate produced is 11 gallons per hour (41.6LPM) per 1,000,000 BTU of gas burned.

### **WARNING**

**In a common vent system, DO NOT POWER THE UNIT OFF! Equipment damage may occur. To disable operation, turn off gas, NOT power. If you have any questions, please call Technical Support.**

# PART 5. PIPING

## A. HYDRONIC HEATING BOILER PIPING

The appliance is designed to function in a closed loop (minimum) 12 PSI System. Never let the appliance operate without a minimum of 10 PSI water pressure, this assures that the heat exchanger can be completely purged of air, failure to do so could cause damage. It is important to note that the appliance is flow dependent for proper efficiency and life expectancy; therefore, primary-secondary piping or use of a low loss header design is always

recommended. Each appliance should have an Air Eliminator, which will remove air from the Hydronic System. Always follow good piping practices. Observe minimum 1" clearance to combustibles around all uninsulated hot water pipes, or when openings around pipes are not protected by non-combustible materials. On an appliance installed above the level of the highest heat transfer device, some state and local codes require a low water cut off

device at the time of installation by the installer. A water flow switch is provided as standard and will take the place of a low water cut-off. If the appliance supplies hot water to heating coils in air handler units, flow control valves or other devices must be installed to prevent gravity circulation of boiler water in the coils during the cooling cycle.

Basic piping connection steps are listed below. A drawing, specific to your application can be obtained from your distributor or the Manufacturer, which will guide you through proper installation of the appliance.

- 1) Pipe properly, in accordance with generally accepted piping principals or the Manufacturers specific documents.
- 2) Connect system return to the pipe entering the appliance.
- 3) Connect system supply to the pipe leaving the appliance containing the Relief Valve.
- 4) Install Drain Valve on system supply.

**NOTE:** The appliance cannot be drained of water without purging the unit with air pressure, 15 PSI minimum. The system's air vent must be closed during this process.

**(TABLE 5-1) BOILER PIPING**

Model	Boiler Only		Design ΔT		Minimum Manifold Pipe Sizes			
	GPM ΔP	LPMΔP			Single	Double	Triple	Quad
HW 800	30.2@2'	114.3@0.6M	50.0 °F	27.8 °C	1.5"	2"	2.5"	3"
HW 1000	38.0@2.6'	143.8@0.8M	50.0 °F	27.8 °C	2"	2.5"	3"	4"
HW 1500	56.8@5.3'	215@1.6M	50.0 °F	27.8 °C	2"	3"	4"	6"

Note: Flow rates shown above are for clean, closed loop systems, if there is any doubt about system cleanliness proper precautions should be taken, and the flow rates for appliances as shown in Table 5-2 should be utilized.

**B. BOILER SCHEMATIC DRAWINGS**

**TWO BOILER SCHEMATIC TO SYSTEM SEPARATOR**

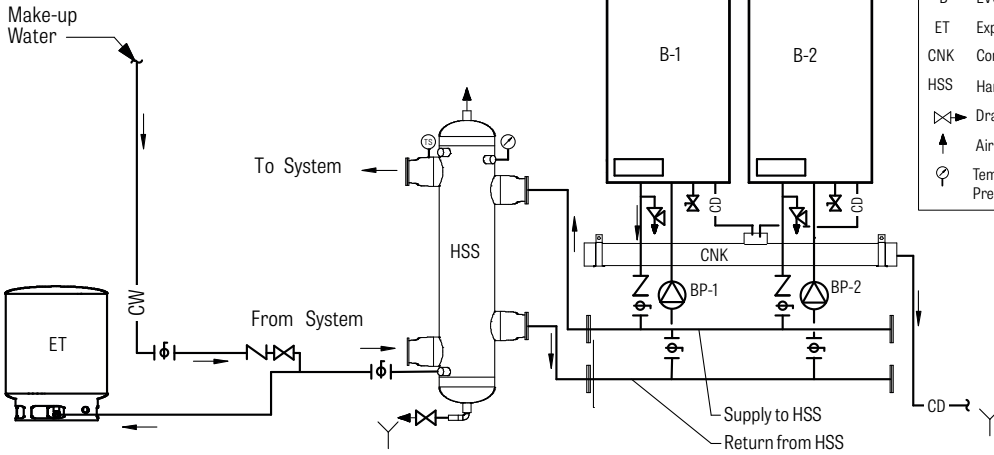

**LEGEND**

HWS	Hot Water Supply		Thermometer
HWR	Hot Water Return		Pump
CW	Cold Water		Ball valve
CD	Condensate Drain		Fill valve
B	EVO Boiler Stand Mounted		Flow direction
ET	Expansion Tank		Pressure Relief valve
CNK	Condensate Neutralizer		Gas cock
HSS	Hamilton System Separator		Floor Drain
	Drain valve		Temperature Sensor
	Air vent		Boiler pump
	Temperature & Pressure Gauge		Ball Valve with Built-in Check Valve

**THREE BOILER SCHEMATIC TO SYSTEM SEPARATOR WITH ONE ZONE FOR INDIRECT HOT WATER TANK, SYSTEM MAY ALSO BE DESIGNED WITH EXTERNAL HEAT EXCHANGER**

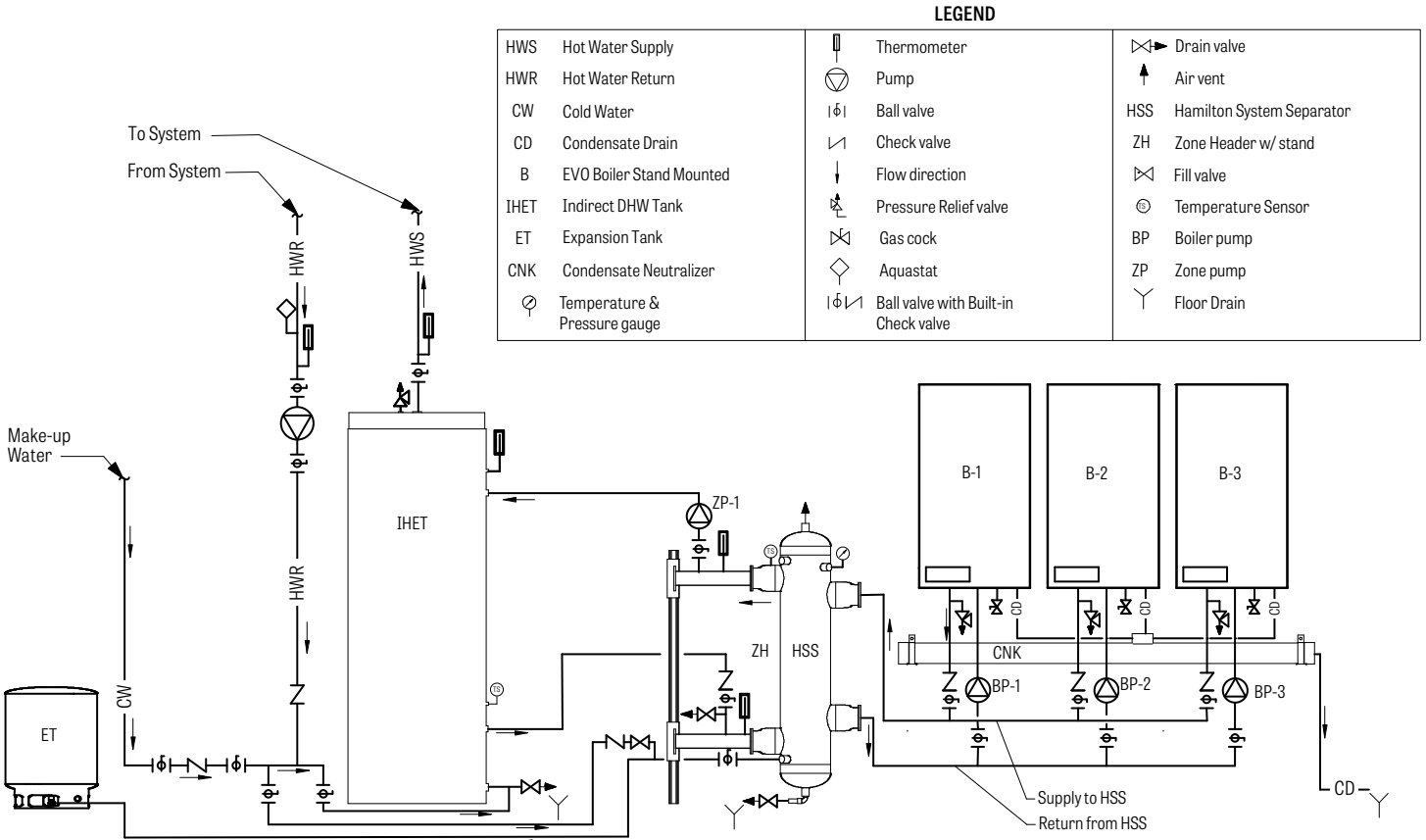

**LEGEND**

HWS	Hot Water Supply		Thermometer
HWR	Hot Water Return		Pump
CW	Cold Water		Ball valve
CD	Condensate Drain		Check valve
B	EVO Boiler Stand Mounted		Flow direction
IHET	Indirect DHW Tank		Pressure Relief valve
ET	Expansion Tank		Gas cock
CNK	Condensate Neutralizer		Aquastat
	Temperature & Pressure gauge		Ball valve with Built-in Check valve
	Drain valve		Air vent
	HSS		HSS
	ZH		ZH
	Fill valve		Temperature Sensor
	Temperature Sensor		Boiler pump
	BP		Zone pump
	ZP		Floor Drain

**IMPORTANT NOTE:** The above are representative drawings; must conform to local codes. Consult factory for Custom System Solutions.

## C. FILL & PURGE HEATING (HYDRONIC) SYSTEM

- 1) Attach hose to balance and purge hose connector and run to drain.
- 2) Close the other side of the balance and purge valve.
- 3) Open first zone balance and purge valve, so as to let the water flow out of the hose. If zone valves are used, open zone valves one at a time, manually. (NOTE: please check manufacturer's instructions prior to opening valves manually, so as not to damage the valve.)
- 4) Manually operate fill valve regulator. When water runs out of hose, connected to the balance and purge valve, in steady stream (with no air bubbles), close balance and purge valve to stop the water from flowing. Disconnect hose and connect to next zone to be purged.
- 5) Repeat procedure for additional zones (one at a time).

Upon completion, make sure that the fill valve is in automatic position and each zone balance and purge valve is in the open position and zone valves are positioned for automatic operation.

**NOTE:** Installations that incorporate Standing Iron Radiators and systems with manual high point vents:

Follow the above procedure, then starting with nearest manual air vent, open vent until water flows out; close vent. Repeat procedure, working your way toward furthest air vent. It may be necessary to install a basket strainer or filtration in an older hydronic system where larger amounts of sediment may be present. Periodic cleaning of the strainer may be necessary.

For appliance water and/or odd water systems, please make note of these additional guidelines:

- **Thoroughly flush the system (without appliance connected) to remove sediment. The high-efficiency heat exchanger can**

**be damaged by build-up or corrosion due to sediment.**

- **Do not use petroleum-based cleaning or sealing compounds in the appliance system. Gaskets and seals in the system may be damaged. This can result in substantial property damage.**
- **Do not use 'homemade cures' or 'boiler patent medicines'. Serious damage to the appliance, personnel, and/or property may result.**
- **Continual fresh make-up water will reduce appliance life. Mineral buildup in the heat exchanger reduces heat transfer, overheats the stainless steel heat exchanger, and causes failure. Addition of oxygen carried in by makeup water can cause internal corrosion in system components. Leaks in appliance or piping must be repaired at once to prevent makeup water.**

## D. WATER HEATING PIPING

1 Use only the pipe sizes shown and a pump meeting the listed specifications in the following tables:

**\*NOTE:** Individual Appliance Piping pressure drop used in the tables is based on 20 feet of straight pipe, 6 elbows, 2 tees, 2 full port ball valves and 2 unions.

2) The city cold water supply to the water heating system should be connected between the appliance outlet and the storage tank or the storage tank directly. This will help minimize unnecessary short cycling due to small hot water draws. Higher efficiency can be obtained through use of our optional CWIS™—Cold Water Injection System in any Storage Tank.

3) Isolation valves should be installed on each appliance and on the cold and hot water system connections.

Upon completion of piping, fill and properly purge of all air. Open all valves and start circulating pump. Consult the Manufacturer for specific piping diagrams for your application.

**NOTE:** Minimum pump selection is based on piping sizes shown below and water hardness not to exceed 12 grains per gallon and total maximum equivalent piping length of 60 feet.

**(TABLE 5-2) WATER HEATER PIPING**

Model	Boiler Only		Design $\Delta T$		Minimum Manifold Pipe Sizes			
	GPM $\Delta P$	LPM $\Delta P$			Single	Double	Triple	Quad
HW 800	51.4@12'	194.5@3.6M	30°F	16.7°C	2" (50.8mm)	3" (76.2mm)	4" (101.6mm)	6" (152.4mm)
HW 1000	64.7@13.2'	244.9@4.0M	30°F	16.7°C	2.5" (63.5mm)	4" (101.6mm)	4" (101.6mm)	6" (152.4mm)
HW 1500	82.9@17.3'	313.8@5.3M	35°F	19.4°C	2.5" (63.5mm)	4" (101.6mm)	6" (152.4mm)	6" (152.4mm)

\*Water heater and piping as described above.

E. WATER HEATING SCHEMATIC DRAWINGS

One water heater schematic to single tank

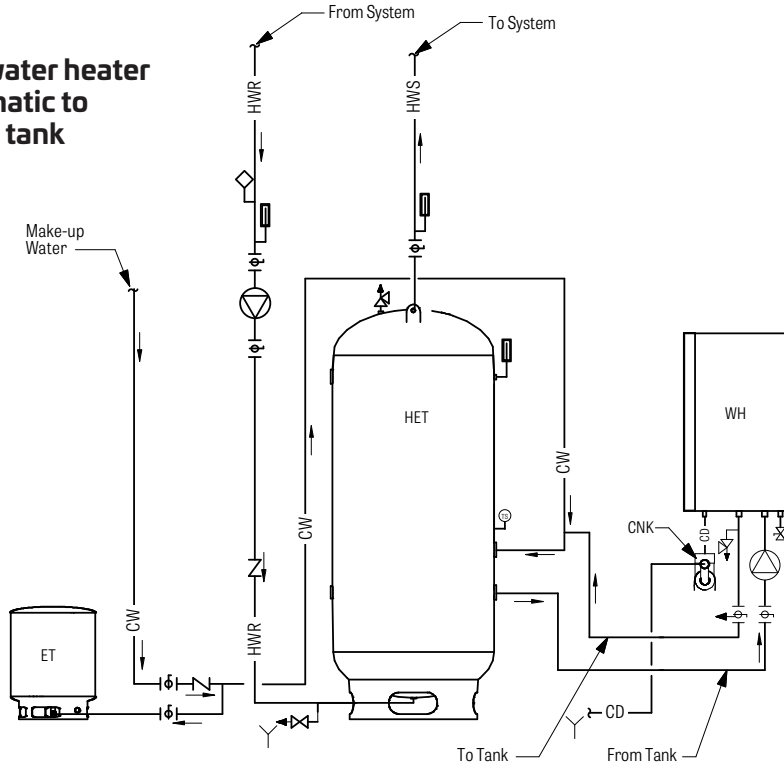

LEGEND

HWS	Hot Water Supply		Thermometer
HWR	Hot Water Return		Pump
CW	Cold Water		Ball valve
CD	Condensate Drain		Check valve
WH	Water Heater with Stand		Aquastat
HET	Storage Tank		Flow direction
ET	Expansion Tank		Pressure Relief valve
CNK	Condensate Neutralizer		Ball Valve with built-in Drain Valve
	Drain valve		Gas cock
	Air vent		Floor drain
	Temperature Sensor		

One water heater schematic to single tank with mixing valves

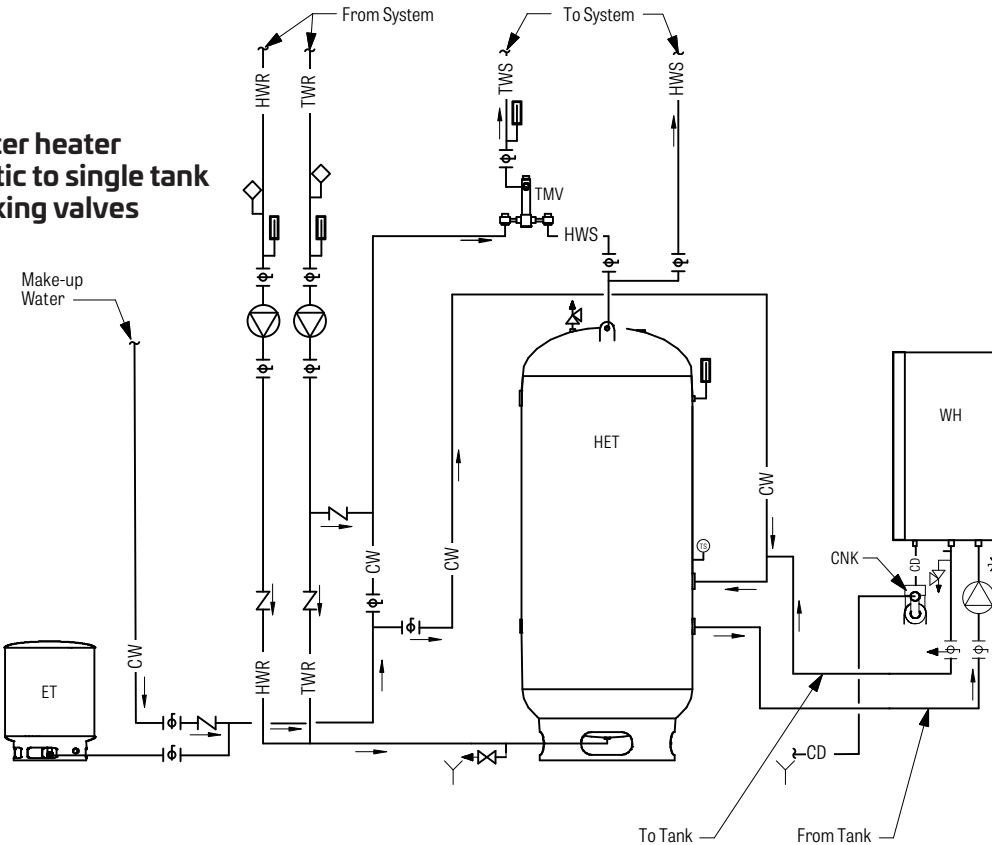

LEGEND

HWS	Hot Water Supply		Thermometer
HWR	Hot Water Return		Pump
CW	Cold Water		Ball Valve
TWS	Tempered Water Supply		Check Valve
TWR	Tempered Water Return		Aquastat
CD	Condensate Drain		Flow Direction
WH	Water Heater with Stand		Pressure Relief Valve
HET	Storage Tank		Ball Valve with built-in Drain Valve
ET	Expansion Tank		Gas cock
CNK	Condensate Neutralizer		Drain valve
TMV	Thermostatic Valve		Air vent
	Thermometer		Temperature Sensor
	Pump		Floor drain
	Ball Valve		
	Check Valve		
	Aquastat		
	Flow Direction		
	Pressure Relief Valve		
	Ball Valve with built-in Drain Valve		
	Gas cock		
	Drain valve		
	Air vent		
	Temperature Sensor		
	Floor drain		

**IMPORTANT NOTE:** The above are representative drawings; must conform to local codes. Consult factory for Custom System Solutions.

E. WATER HEATING SCHEMATIC DRAWINGS (continued)

One water heater schematic to single tank with mixing valve and CWIS™

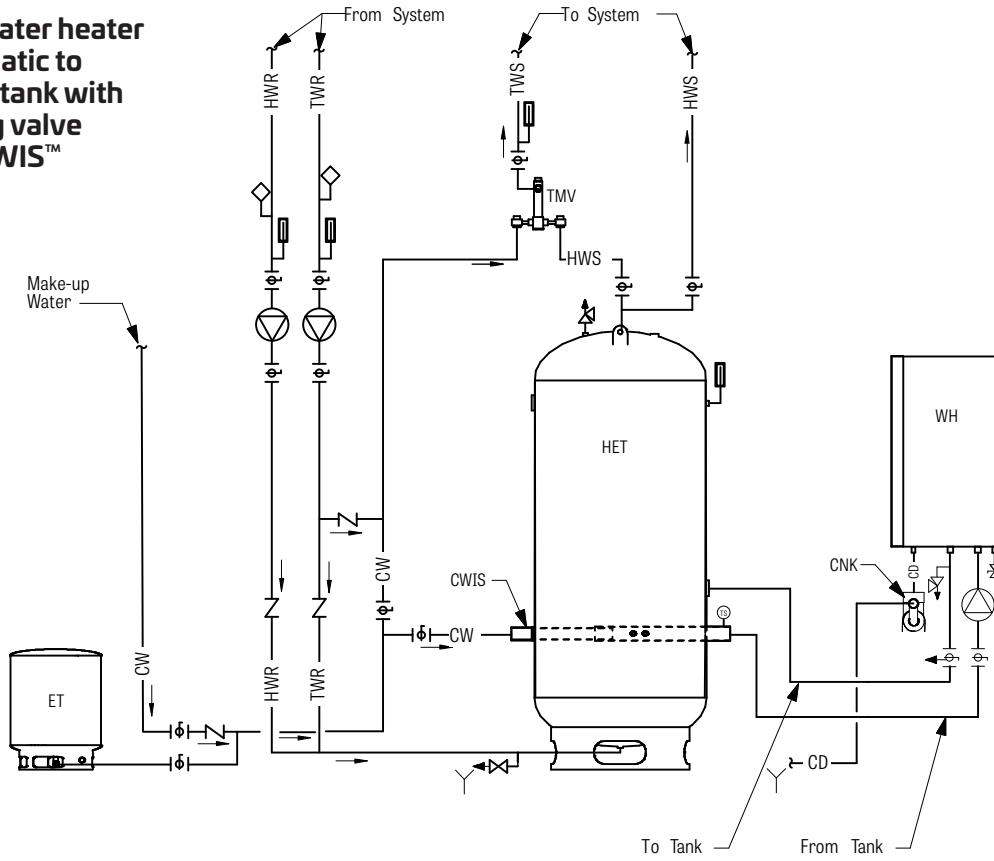

LEGEND

HWS	Hot Water Supply
HWR	Hot Water Return
CW	Cold Water
TWS	Tempered Water Supply
TWR	Tempered Water Return
CD	Condensate Drain
WH	Water Heater with Stand
HET	Storage Tank
ET	Expansion Tank
CNK	Condensate Neutralizer
TMV	Thermostatic Mixing Valve
⊞	Thermometer
⊞	Pump
⊞	Ball valve
⊞	Check valve
⊞	Aquastat
⊞	Flow direction
⊞	Pressure Relief Valve
⊞	Ball with Built-in Drain Valve
⊞	Gas cock
⊞	Drain valve
⊞	Air vent
⊞	Temperature Sensor
⊞	Floor Drain
CWIS	Cold Water Injection System

Three water heater schematic to single tank

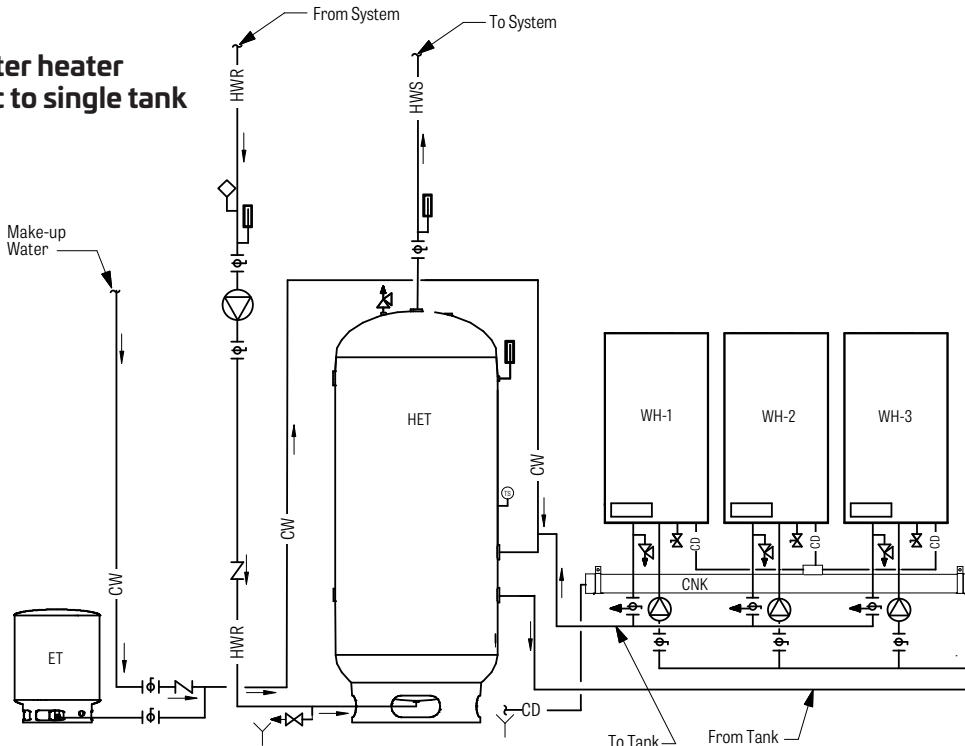

LEGEND

HWS	Hot Water Supply
HWR	Hot Water Return
CW	Cold Water
CD	Condensate Drain
WH	Water Heater with Stand
HET	Storage tank
ET	Expansion tank
CNK	Condensate Neutralizer
⊞	Thermometer
⊞	Pump
⊞	Ball valve
⊞	Check valve
⊞	Aquastat
⊞	Flow direction
⊞	Pressure Relief Valve
⊞	Ball Valve with built-in Drain Valve
⊞	Gas cock
⊞	Drain valve
⊞	Air vent
⊞	Temperature Sensor
⊞	Floor drain

**IMPORTANT NOTE:** The above are representative drawings; must conform to local codes. Consult factory for Custom System Solutions.

**Three water heater schematic to single tank**

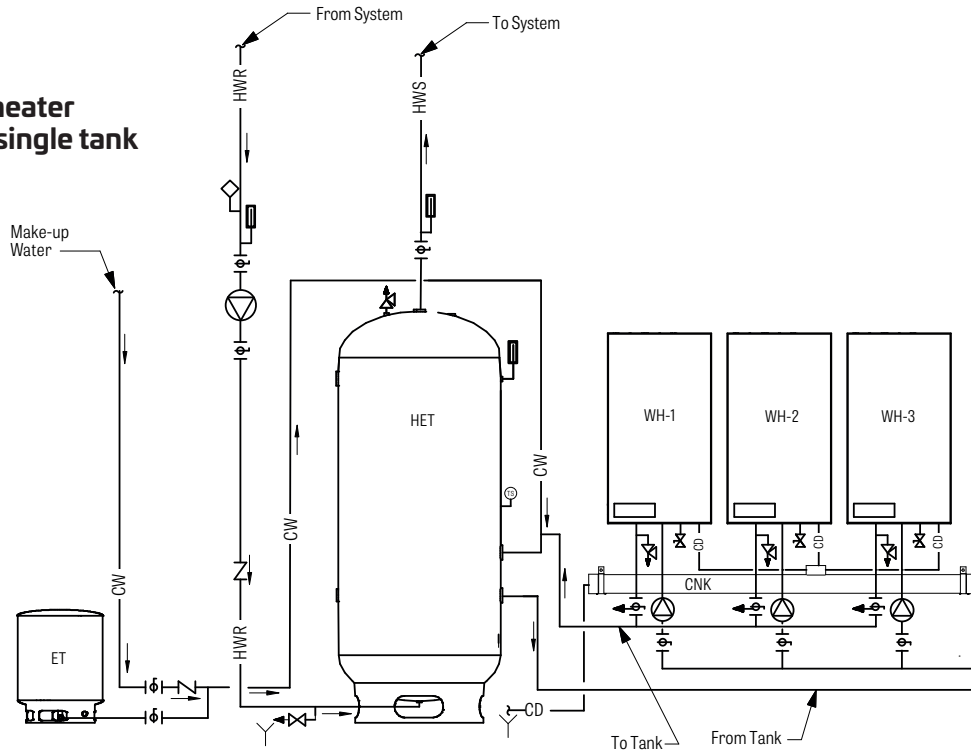

**LEGEND**

HWS	Hot Water Supply
HWR	Hot Water Return
CW	Cold Water
CD	Condensate Drain
WH	Water Heater with Stand
HET	Storage tank
ET	Expansion tank
CNK	Condensate Neutralizer
	Thermometer
	Pump
	Ball valve
	Check valve
	Aquastat
	Flow direction
	Pressure Relief Valve
	Ball Valve with built-in Drain Valve
	Gas cock
	Drain valve
	Air vent
	Temperature Sensor
	Floor drain

**Three water heater schematic to single tank with mixing valve**

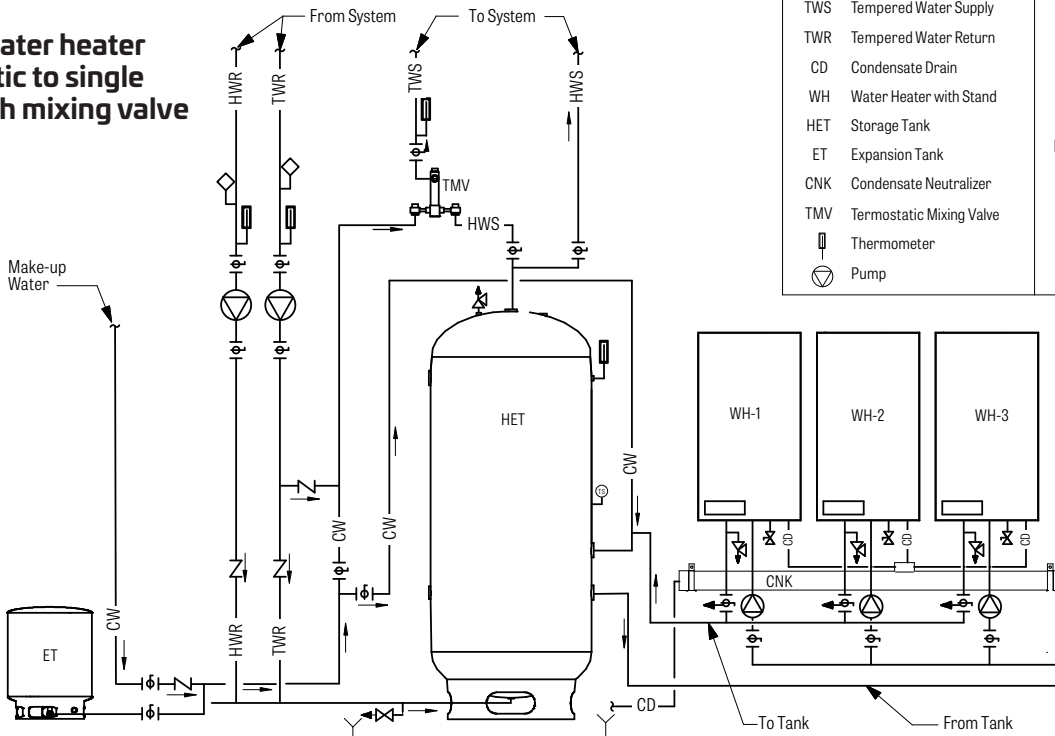

**LEGEND**

HWS	Hot Water Supply		Ball valve
HWR	Hot Water Return		Check valve
CW	Cold Water		Aquastat
TWS	Tempered Water Supply		Flow direction
TWR	Tempered Water Return		Pressure Relief valve
CD	Condensate Drain		Ball Valve with built-in Drain Valve
WH	Water Heater with Stand		Gas cock
HET	Storage Tank		Drain valve
ET	Expansion Tank		Air vent
CNK	Condensate Neutralizer		Temperature sensor
TMV	Thermostatic Mixing Valve		Floor drain
	Thermometer		
	Pump		

**IMPORTANT NOTE:** The above are representative drawings; must conform to local codes. Consult factory for Custom System Solutions.

E. WATER HEATING SCHEMATIC DRAWINGS (continued)

Three water heater schematic to single tank with mixing valve AND CWIS™

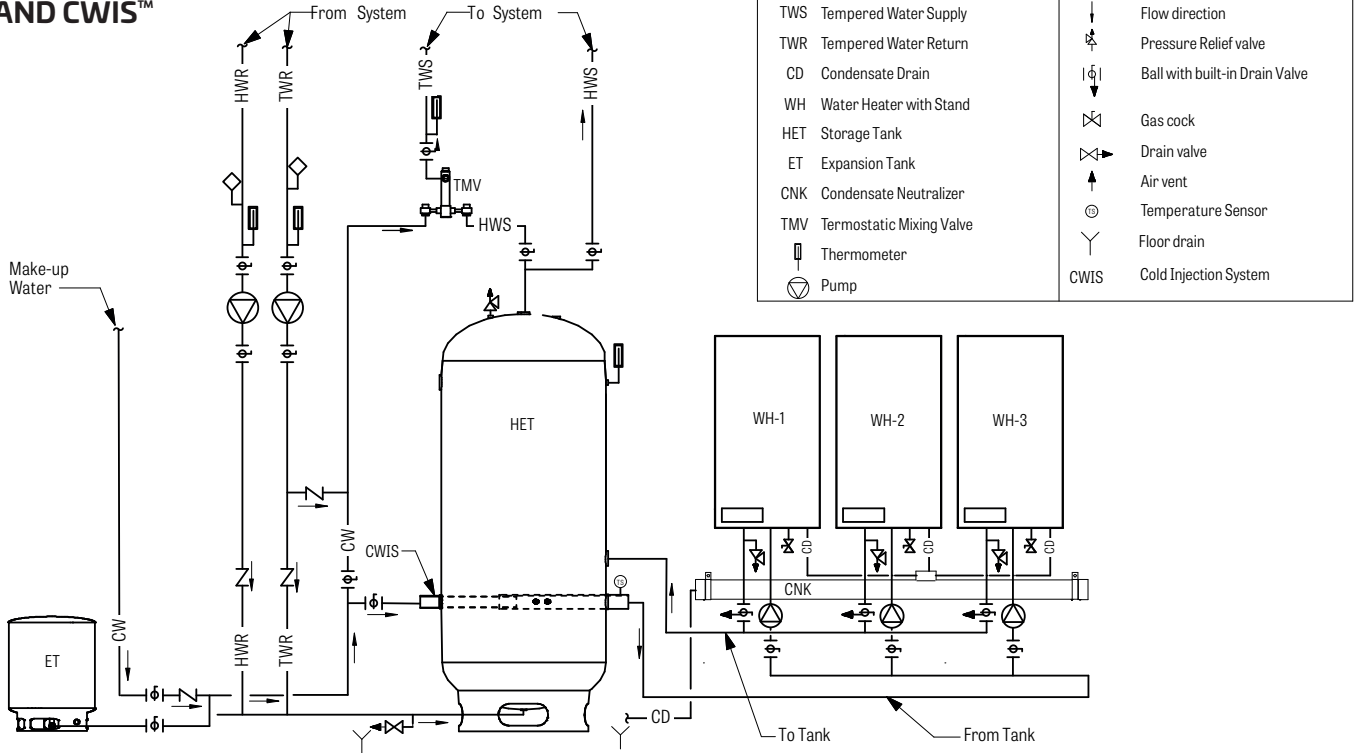

LEGEND

HWS Hot Water Supply	Ball valve
HWR Hot Water Return	Check valve
CW Cold Water	Aquastat
TWS Tempered Water Supply	Flow direction
TWR Tempered Water Return	Pressure Relief valve
CD Condensate Drain	Ball with built-in Drain Valve
WH Water Heater with Stand	Gas cock
HET Storage Tank	Drain valve
ET Expansion Tank	Air vent
CNK Condensate Neutralizer	Temperature Sensor
TMV Thermostatic Mixing Valve	Floor drain
Thermometer	
Pump	CWIS Cold Injection System

Three water heater schematic to single tank with CWIS™

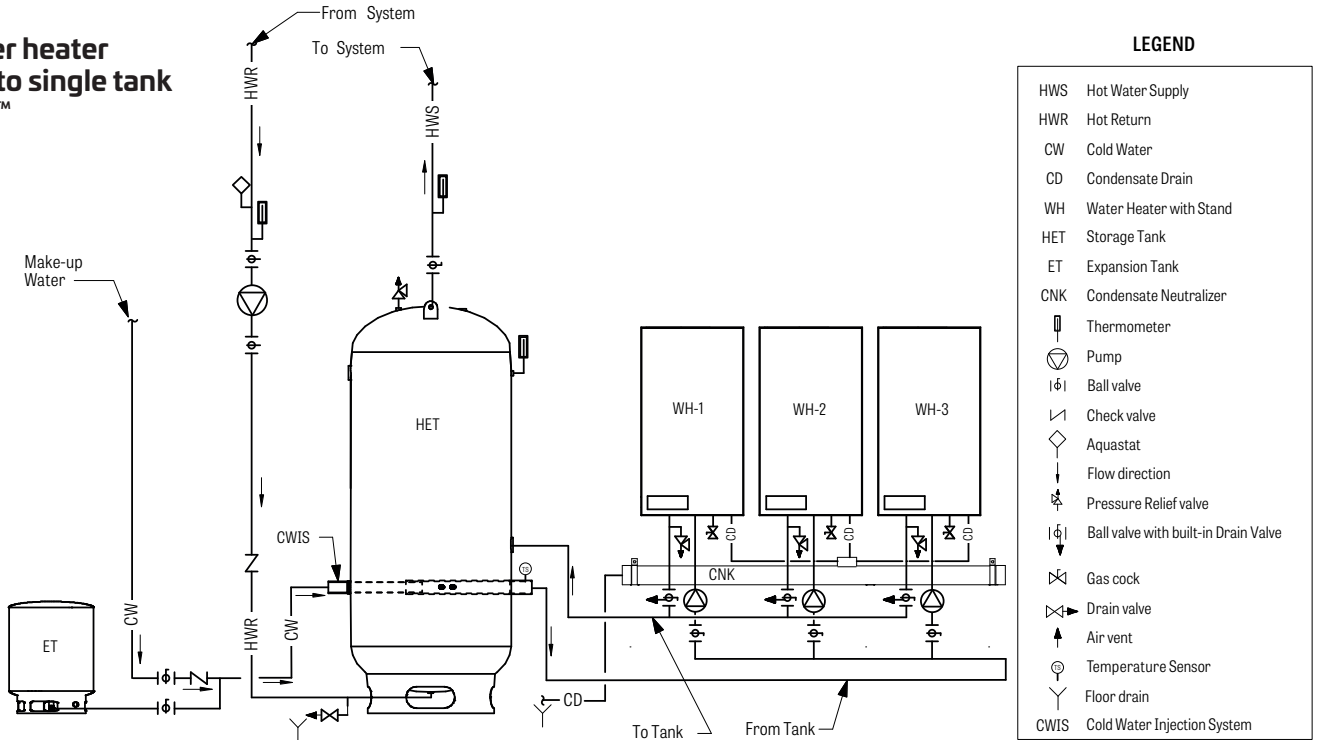

LEGEND

HWS Hot Water Supply
HWR Hot Return
CW Cold Water
CD Condensate Drain
WH Water Heater with Stand
HET Storage Tank
ET Expansion Tank
CNK Condensate Neutralizer
Thermometer
Pump
Ball valve
Check valve
Aquastat
Flow direction
Pressure Relief valve
Ball valve with built-in Drain Valve
Gas cock
Drain valve
Air vent
Temperature Sensor
Floor drain
CWIS Cold Water Injection System

**IMPORTANT NOTE:** The above are representative drawings; must conform to local codes. Consult factory for Custom System Solutions.

**Three water heater schematic to two tanks**

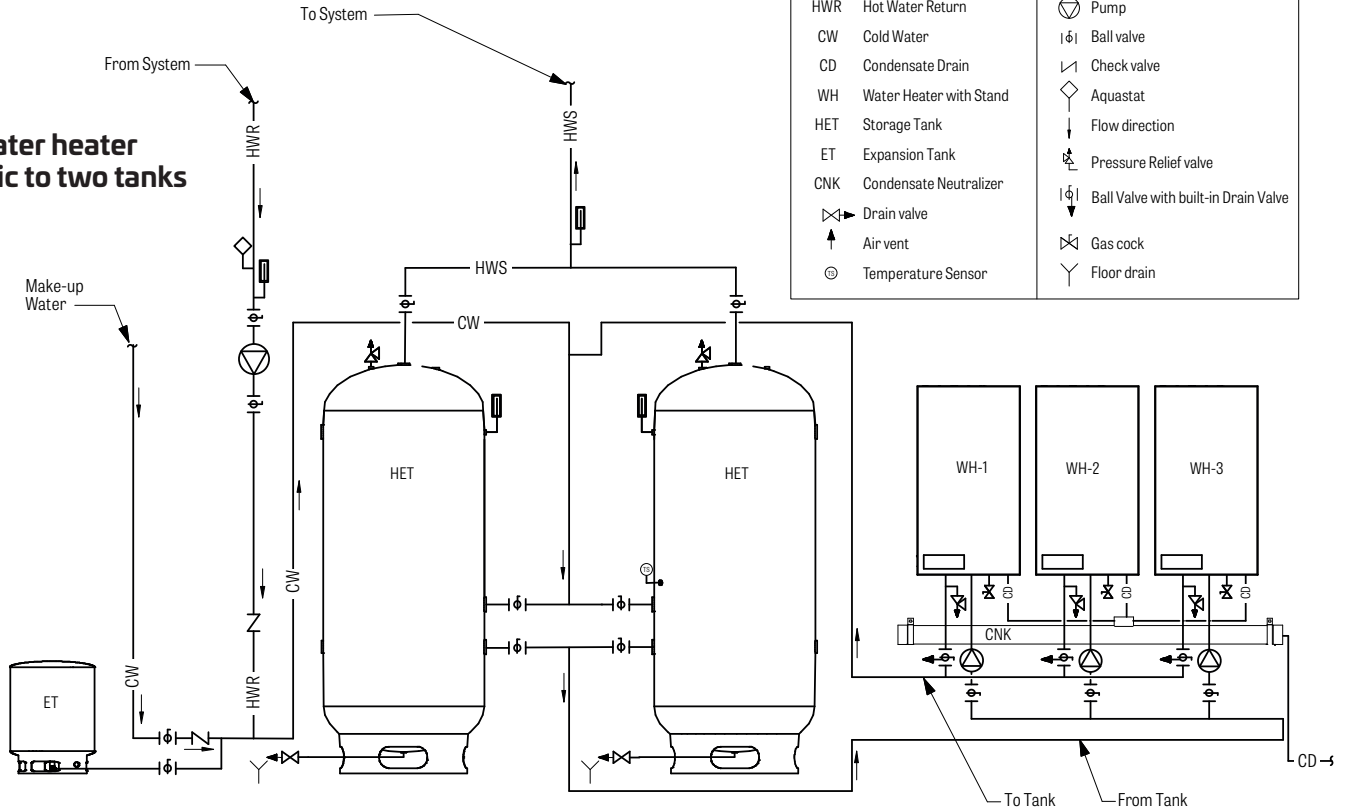

**Three water heater schematic to two tanks with CWIS™**

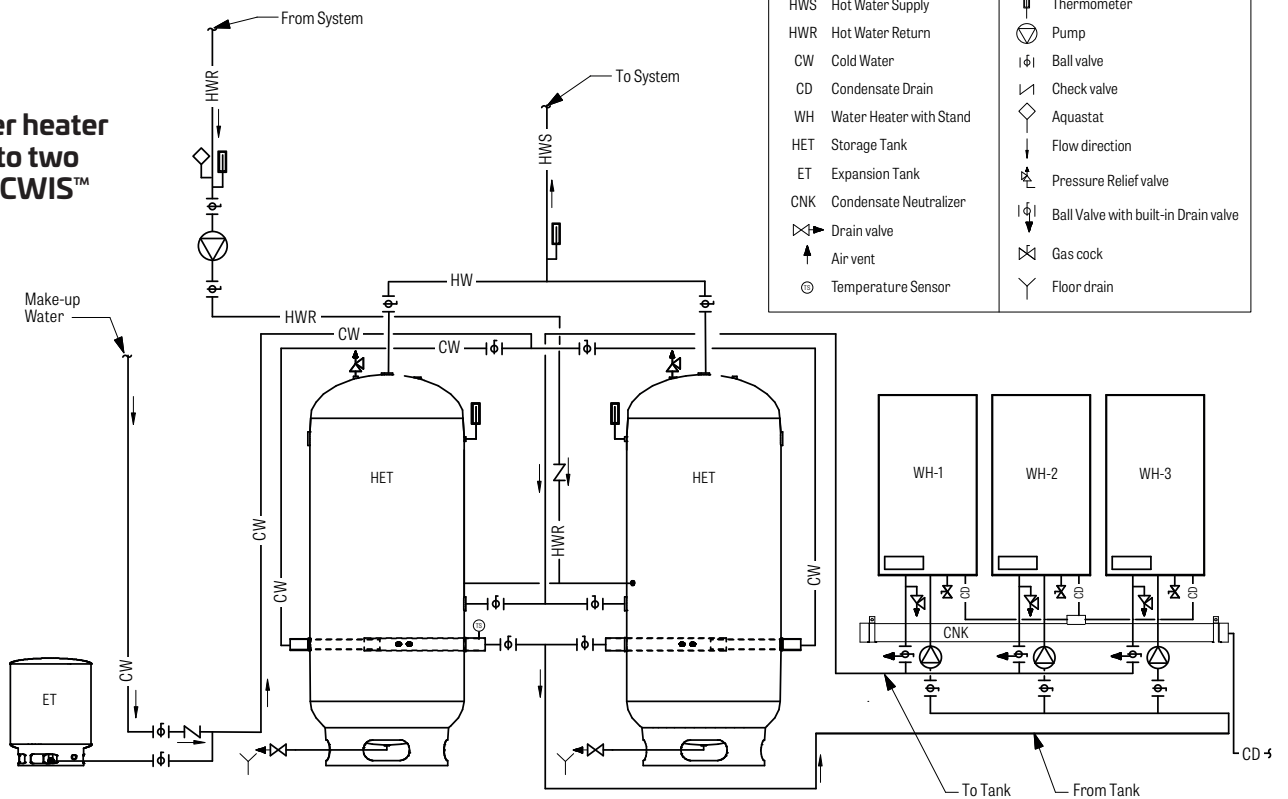

**IMPORTANT NOTE:** The above are representative drawings; must conform to local codes. Consult factory for Custom System Solutions.

## PART 6. START-UP PROCEDURES

### A. ITEMS TO BE CHECKED BEFORE LIGHTING THE APPLIANCE

It is recommended that you read this entire section of Start-Up Procedures to get a better understanding of how the appliance operates before you start the unit and use (Start-Up Checklist) as a check and to document and confirm all conditions are correct. All appliance start ups should be conducted by properly qualified professionals.

1. Make sure that you follow the lighting instructions before running the appliance.
2. Check and make sure the circulating pump is running, and that the pressure transducers and/or flow switch are operating correctly.
3. Make sure that the Gas is turned on outside the rear of the cabinet of the appliance.
4. Double check to be sure the temperature setting is correct.
5. Make sure the unit is properly grounded and the electrical wiring meets the requirements of the Electrical section (Part 2, Section A).
6. Make sure that no valves are placed between the relief valve and the appliance. The relief valve must be installed in such a manner that the discharge will be conducted to a suitable place for disposal when relief occurs. Ensure that no reducing coupling or other restriction is installed in the discharge line, and that the discharge line is installed to allow complete drainage of both the valve and the line.
7. Turn on the power to the appliance. The Setpoint Temperature of the appliance will appear in the display at this time. If a fault code appears, correct the fault before operating. The appliance will now run its pre-purge and ignition cycles, then begin heating, which will be indicated by the orange flame in the lower right corner of the display.

### B. LIGHTING INSTRUCTIONS

#### FOR YOUR OWN SAFETY, READ BEFORE OPERATING!

1. This appliance does not have a pilot light. It is equipped with an ignition device which automatically lights the burner. Do not try to light the burner by hand.
2. BEFORE OPERATING smell all around the appliance area for gas. Be sure to smell next to the floor because some gas is heavier than air and will settle on the floor.

#### WHAT TO DO IF YOU SMELL GAS

- Do not try to light any appliance.
- Do not touch any electric switch; do not use any phone in your building.
- Immediately call your gas supplier from a neighbor's phone. Follow the gas suppliers' instructions.
- If you cannot reach your gas supplier, call the fire department.

#### **WARNING**

If you do not follow these instructions exactly, a fire or explosion may result, causing property damage, personal injury, or loss of life.

## B. LIGHTING INSTRUCTIONS (continued)

3. Turn on gas shutoff valve (located outside the cabinet on the rear of the appliance) so that the handle is aligned with the gas pipe. If the handle will not turn by hand, don't try to repair it; call a qualified service technician. Force or attempted repair may result in a fire or explosion.
4. Do not use this appliance if any part has been under water. Immediately call a qualified service technician to inspect the appliance and to replace any part of the control system and any gas control which has been under water.
5. The appliance shall be installed so the gas ignition system components are protected from water (dripping, spraying, rain, etc.) during appliance operation and service (circulator replacement, condensate trap, control replacement, etc.).

## C. OPERATING INSTRUCTIONS

1. **STOP!** Make sure you have read the safety information above.
2. Turn off all electric power to the appliance.
3. This appliance is equipped with an ignition device which automatically lights the burner. Do not try to light the burner by hand.
4. Turn gas shutoff valve clockwise to "off"—do not force it.
5. Wait five (5) minutes to clear out any gas. If you then smell gas, STOP! Follow the instructions from Section B: Lighting Instructions in the safety information. If you don't smell gas, go to the next step.
6. Turn the gas shutoff valve counter clockwise to "on."
7. Turn on all electric power to appliance.
8. Set the thermostat to the desired setting.
9. If the appliance will not operate, follow the instructions "To Turn Off Gas To Appliance" (Part 7, Section F, and call your service technician or gas supplier.

## D. INI PROCESS AND SERVICE PROCEDURES

The HOT™ Controls, contain a unique function, they track the accuracy, degradation and fouling of all connected sensors and pressure transducers and the major components of the system; appliance heat exchanger, fan, pump and igniter.

This tracking is accomplished by taking readings of and creating trend lines for each mentioned item and then running calculations of some versus others to determine how the need for maintenance of specific components is progressing.

Aside from the use of up to 11 different sensors to monitor items like incoming gas and leaving fan pressure and pressure at the exiting side of the heat exchanger and

condensate drain connection, we have an initialization (INI) process that takes place automatically in the background to collect this data during steady state conditions and record it, to populate the trend lines.

The creation of a baseline: Zero INI (Z-INI), is an important step in this process and normally occurs during the commissioning of the system. Within 2 minutes of powering the appliances up, a question will be presented on screen: "A ZERO INI IS REQUIRED—RUN NOW?" YES or NO, unless the entire system is fully commissioned and operating normally, answer NO. The question will be presented every 15 minutes until you finally select "YES". It is best not to answer YES until all appliances

are started and combustion set. When they are all ready, turn off power to all at the switch on the front near the display. Go back to the appliance with two displays, power it and all others on, and when the question is presented again (two minutes or less), answer YES on each individual appliance. The Z-INI should be completed in less than 10 minutes.

If you end up with the Z-INI running when things are not quite 100% as they will be when the system is up and running, not to worry, with the proper password, you can overwrite the Z-INI with a replacement, so you are sure your Z-INI is a true baseline to work from.

## D. INI PROCESS AND SERVICE PROCEDURES (continued)

### To force an INI to run

(this can be done by all appliances in the cascade or individually):

- 1) Enter Setup menu
- 2) Press the back and down arrow simultaneously for 3 sec., to enter the password screen, and enter password level 1 (there is an advanced Level 2 with more options, available if you have attended training at the Manufacturer's factory).
  - Installer level – EAZ1LVL
- 3) The setup screen will now have additional selections, scroll down to start INI (be sure only to select Zero if you have had a commissioning issue and need an updated proper baseline to work from), and select it.
- 4) The INI is now in progress, and will end after a few minutes at which point normal operation will resume. A scrolling message across the bottom of each appliance (if in a Cascade) will indicate it is in process.

Note that the INI process normally occurs in the background, during no call for heat and is rarely noticed. Subsequent INI's happen on a pre-determined basis; they are based on parameter IN1 setting of 1 – 30 days and therefore can be adjusted to fit the environment of the installation. If, you have an operation that requires heat 24 hours a day, when the system setting of days between INI's has been reached, and there is a burn cycle in process, the controls will look to parameter IN2; waiting hours of burn time before a forced INI occurs; default setting of 2.5 hours. When that quantity of hours has been reached after the days between setting, a forced INI will occur.

A forced INI occurs like this; the burners of all appliances in the Cascade (or the stand alone appliance) are shut down, the pump is run until the gradient (moving temperatures) between the Inlet (T2) sensor and the outlet (T1.2) sensor is less than parameter IN3; with a default setting of 0.36°F/second  $\Delta T$ . At the moment that setting has been reached, the INI process begins and will take a minimum of 3 minutes for a stand-alone or dual appliance system, and 7 – 8 minutes for up to 8 appliances in the Cascade.

The Cascade operating control remembers the settings of all running appliances prior to the forced shut down and immediately following the INI, it returns to those firing rates to minimize any drop in system water temperature.

From the Home screen, you can navigate to the HISTORY tab, select it and tab down to INI DATA, there you can view the recorded INI data from record 00 (Z-INI) through the last 9 that have been recorded. This is the data that decisions and notifications (if opted for) will be sent based on.

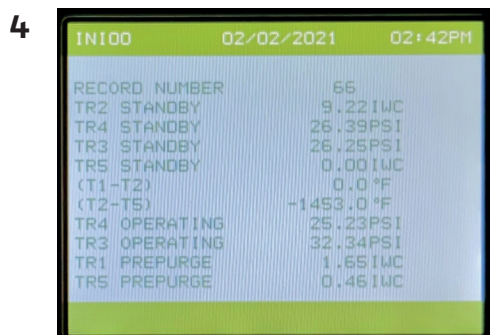
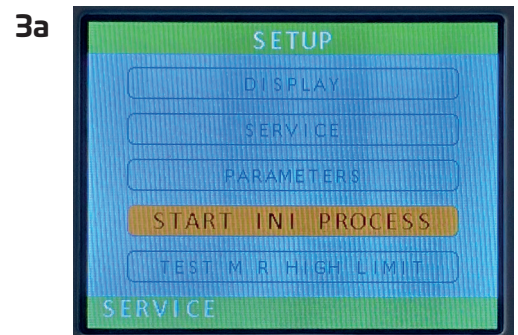
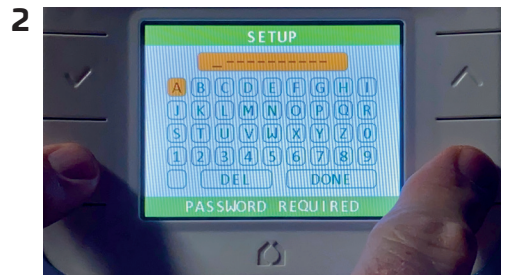
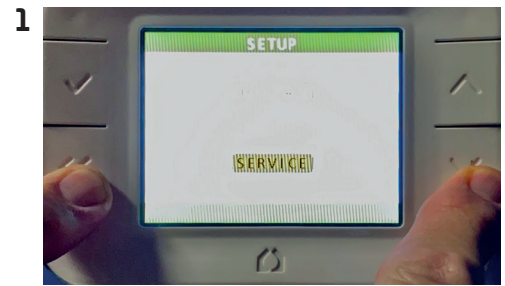

## D. INI PROCESS AND SERVICE PROCEDURES (continued)

### Start Service Mode Procedure:

- 1) Enter Setup menu
- 2) Scroll down to service, and select using the  $\checkmark$  button
- 3) Select burner, and then start
- 4) The display will return to the setup menu, and service mode has begun. Select service again, and then burner.
  - There will now be a new options in place of start; stop & speed. Set speed to 50% using the up and down arrows., using 100% for high fire set up and minimum for low fire set.
- 5) Return to the home screen and select status.
- 6) When the status screen appears, press the down arrow once to show screen 2, showing fan speed and flame signal.
- 7) From here, you can watch the fan during pre-purge and ignition, as well as the flame signal strength at ignition.
- 8) Return to the home screen after ignition, and a flame icon in the lower right corner shows the burner on status.
- 9) Return to the service speed function, and adjust fan speed as needed.
- 10) Service mode will last for 40 minutes, or until canceled. To cancel the service function, select stop from the service menu.



### E. ADJUSTING THE TEMPERATURE ON THE APPLIANCE DISPLAY

On a single unit you change set point through the BDB, for multiple systems it is through the CDB.

Enter the menu labeled Setpoint in the upper right of the display to set the desired operating water temperature. On a boiler, this will be based on the leaving water temperature. On a water heater it will be based either on a connected external (storage tank) sensor, or,

if there is none connected, it will operate based on the incoming water temperature. The range is factory-set at 50–160°F (10–71°C) for water heaters and 50–195°F (10–90.6°C) for boilers. Other special ranges are available by contacting the factory. **If other temperature**

**settings are required, contact the Manufacturer.** Other special parameters may be set by entering a password in the display, varying from end user, installer, advanced, and factory levels. The display can show either °F or °C set in the setup menu, then display options.

### SET POINTS

#### SET POINT GLOSSARY

**Heating** = System setpoint in CH

**Heating Reduced** = System setpoint in CH during night setback hours

**Boiler for heating** = System setpoint in CH when multiple applications are heated.

**iDHW Hot Water Tank** = Storage tank setpoint for iDHW

**Hot Water Reduced** = iDHW during setback hours.

**Boiler for iDHW Load** = System setpoint during iDHW demand.

Home Screen/SETPOINT:



Page one of options:

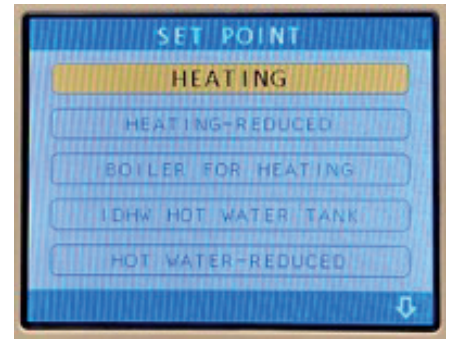

Page two, note arrow at lower right:

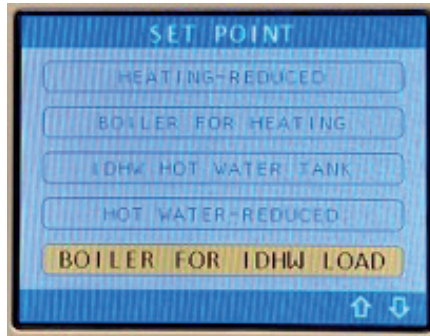

Temperature setting screen:



Be sure to confirm change:

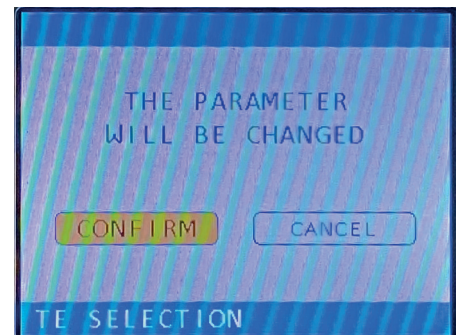

## WATER HEATER OPERATING SAMPLE

All of the following parameters are controlled by a storage tank temperature sensor:

- **Setpoint** = Target Temperature (120°F) Low fire only above this point
- **Offset** = Off Setpoint (3) = 123°F off
- **Hysteresis** = On Setpoint (8) (120 + 3 = 115°F)
- **Proportional Band** = Modulation range (4) (120 - 4 = 116°F, modulation begins)

The appliance turns on at 115°F and when the temperature reaches 116°F the flame will begin to modulate down (approximately 25% of the modulation range per degree F of increase in this example). At 120°F, it will be at low fire and will remain there unless the temperature drops below 120°F and it will modulate back up. If it continues to increase, it will shut down at 123°F.

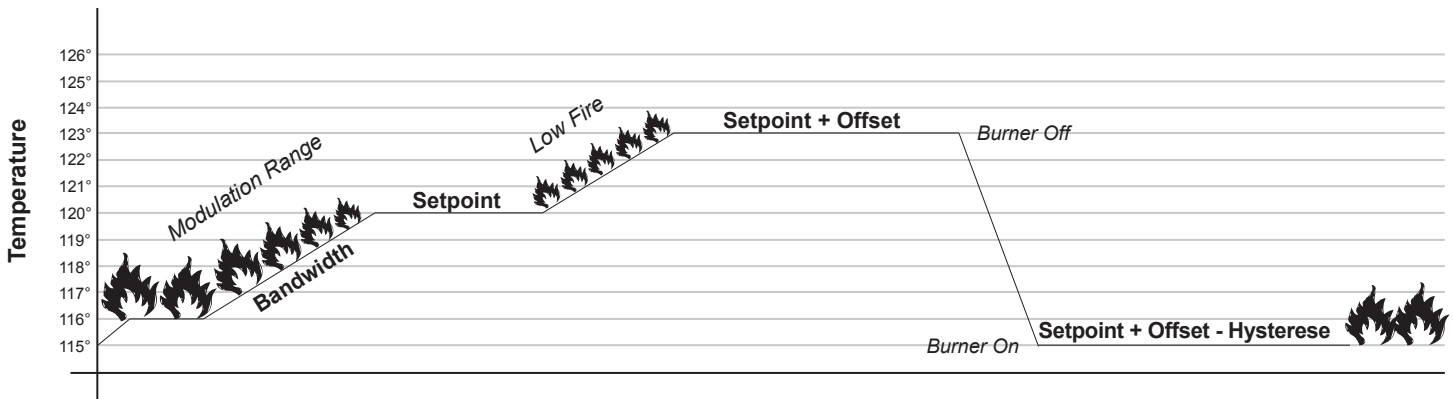

## F. SEQUENCE OF OPERATION

### DANGER

WATER TEMPERATURE OVER 125°F CAN CAUSE SEVERE BURNS INSTANTLY, OR DEATH FROM SCALDS. CHILDREN, THE DISABLED, AND THE ELDERLY ARE AT HIGHEST RISK OF BEING SCALDED. SEE INSTRUCTION MANUAL BEFORE SETTING TEMPERATURE AT WATER HEATER. FEEL WATER BEFORE BATHING OR SHOWERING! TEMPERATURE LIMITING VALVES ARE AVAILABLE.

- When power is first applied to the control, after an initialization phase, the control display will read the temperature Setpoint. The control will initially run through a self-diagnostic routine and then go into its aeration operating mode, where it bumps the pump on and off multiple times to purge the heat exchanger of any air that may have settled there while the power is off. If there is no call for heat, the system will go into an idle state.
 

**NOTE:** The cap on the Automatic Air Vent (if used), located on top of the appliance must remain in the loose state in order for the air to escape as required.
- If the thermostat is calling for heat, the control module will determine if the water temperature is below the programmed set point value minus the switching differential. It will then initiate a heating cycle.
- The control then performs selected system diagnostic checks. If all checks are successfully passed, a pre-purge cycle is initiated (the blower will be on at 80%).
- When the pre-purge period is complete, power is applied to the spark ignitor for 4.5 seconds. Approximately 1/2 second later, flame is verified. If a flame is not verified during the trial-for-ignition, the gas valve is immediately closed and the control will return to Step 3. After four trials, if a flame is not verified, the control will go into a lockout mode. If a flame is confirmed, the control enters the heating mode. The firing rate will be based on the control's proprietary algorithm.
- When water temperature reaches the temperature set point value, the burner will be at minimum firing rate. If, when firing at minimum rate, it reaches temperature setpoint plus offset, the gas valve closes and the control enters a post-purge state (the blower will be on at 80%). At any time if an external thermostat

### DANGER

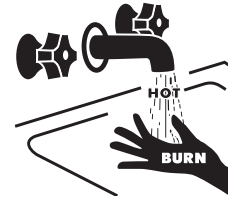

is being used and becomes satisfied, the gas valve will be closed immediately.

- When the post-purge is complete, the control enters an idle state while continuing to monitor temperature and the state of other system devices. If a call-for-heat is received, the control will automatically return to Step 2 in sequence and repeat the entire operating cycle.
- Built in freeze protection: all models will automatically turn the pump on if the heat exchanger reaches 41°F (5°C) and the burner if it reaches 37°F (2.8°C), it will turn off at 50°F (10°C).

**NOTE:** Power must be left on for this protection to function.

During the idle state and heat state, if the control detects an improper operating state from external devices, such as the high-limit switch, the control will illuminate an error code in the display.

## G. 0–10V DIRECT CONTROL

### Direct Control

In the situation where direct control of the appliance is desired (such as from a Building Management System), the appliance can be programmed to receive a 0–10 volt DC signal to control operation.

**Note:** This operation is only possible in individually-controlled units (i.e.: not Cascaded) and when each is individually vented.

There are two variations of this kind of external control (see Parameter S-18): Load Control and Set Point Control. In Load Control, the voltage signal controls the burner firing rate. In Set Point Control, the voltage signal controls the temperature set point of the appliance. (This is similar to how the appliance is controlled when operating without an outside signal.)

### Setting up Direct Control

There are three steps required to set up this mode of operation. First, connect the incoming voltage signal to pins 5 and 6 on the terminal strip.

Next, remove the jumper from the remote thermostat terminals (pins 11 and 12. If this is not done, the appliance will fire based on its internal set point when the voltage drops below 1.0VDC. If the appliance

is set up with any other external signal here, this should be removed as well, or that external signal will take over when the 0-10VDC control signal drops below 1.0VDC.

Next, go to Parameter S18 (PS18) in the Parameter menu and choose the appropriate control setting. (include picture of menu or HMI page)

The PS18 settings are:

- 0=Off (default setting--no external control, any external voltage signal ignored)
- 1=Load Control
- 2=Set Point Control

### Load Control mode (PS18=1)

When a 0-10VDC input is used for load control, the range of 0-10VDC corresponds directly to a modulation percentage (burner firing rate). An input of 10.0VDC results in the maximum default fan speed (modulation) for that appliance, and 1.0VDC results in the minimum default fan speed. The fan speed displayed on the appliance will depend on the range of the fan for that particular appliance.

Type	Minimum Fan Setting (1.0VDC)	Maximum Fan Setting (10.0VDC)	Voltage increment
800	33%	100%	7.44%
1000	31%	100%	7.67%
1500	24%	100%	8.44%

The following is an example of the effect of changing the voltage signal on an appliance in Load Control mode:

- The operational range of an 800 fan is 33%–100%
- 0 - 0.9V = Appliance off
- 1.0V = 33% Fan speed
- 1.3V = 35% Fan speed (3% modulation)
- 4.0V = 55% Fan speed (33% modulation)
- 6.8V = 76% Fan speed (64% modulation)
- 8.9V = 92% Fan speed (88% modulation)
- 10.0V = 100% Fan speed (100% modulation)
- Each volt = 7.44% fan speed or 11.1% modulation

### Set Point Control mode (PS18=2)

When a 0–10VDC input is used for Set Point Control, the range of 0–10VDC corresponds directly to the temperature set point. Contact customer support for assistance with using this mode as multiple parameters may be modified to alter bandwidth and set point sensitivity..

## H. OUTDOOR RESET FUNCTION

Curve or slope—set using the display option in heating set point.

**(FIGURE 6-1) OUTDOOR RESET FUNCTION**

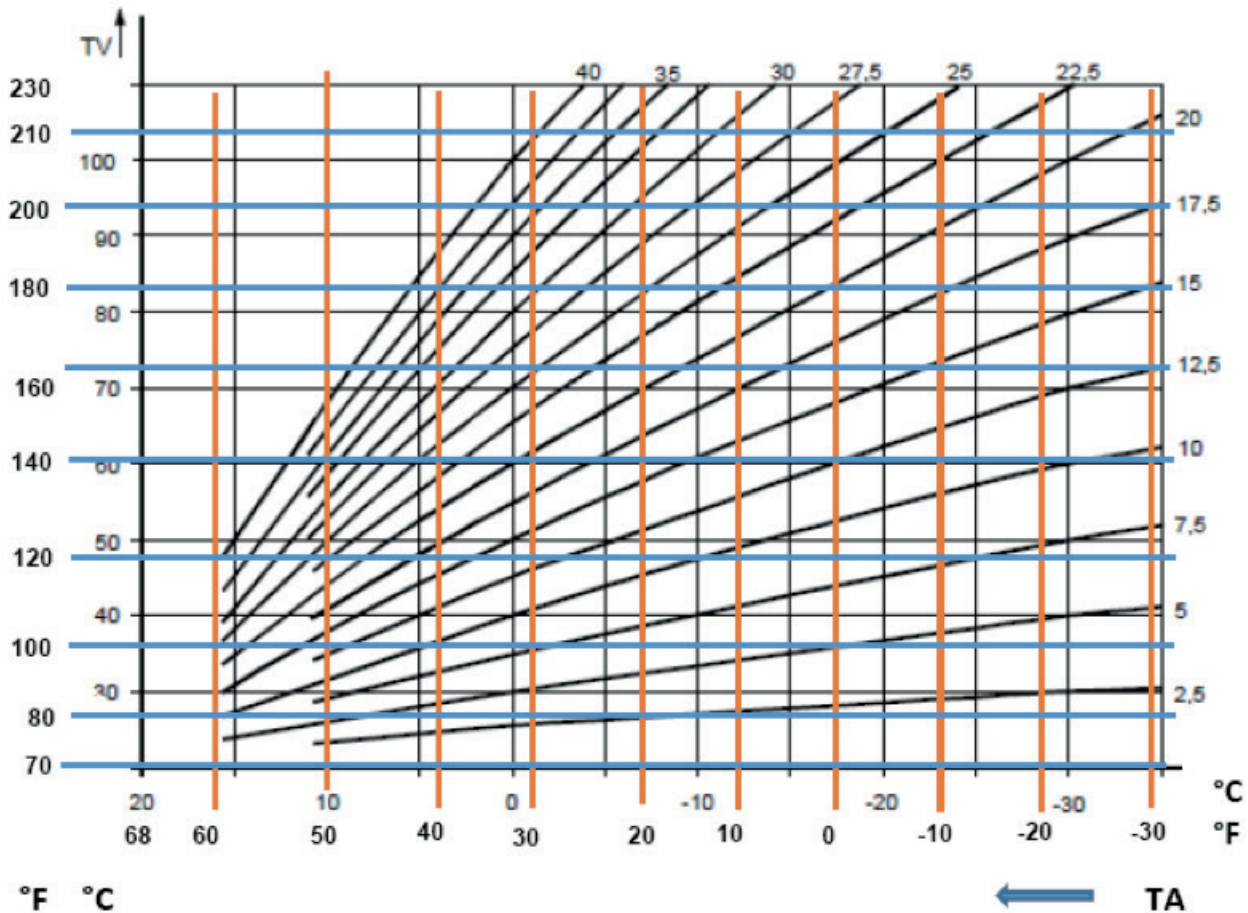

1. You must have the Outdoor Sensor (10K) sensor installed, and the power must have been cycled off and on after its installation.
2. Set the outdoor curve parameter using the chart in Figure 6-1 (TA = outdoor temperature, TV = boiler water temperature), default is 180°F (82.2°C) water at -10°F (-23.3°C) outdoor—slope of 18.
3. Set the Warm Weather Shutdown temperature (default is 64.4°F (18°C); above this temperature, there is no call for heat.
4. Set the building type correction factor (if desired); default is 1.0:
 

A. Old building, not insulated	1.2
B. Building with thick walls >12 inches	1.3
C. Normal building, normal insulation	1.0
D. New building, well insulated	0.9
5. For comfort adjustment after start up, an additional boiler water temperature offset (either higher or lower) is also available in the set up screen, up to 18°F (-7.8°C) higher or lower than the curve calculation.

## PART 7. SERVICE AND MAINTENANCE

### A. SERVICING THE APPLIANCE

1. Shut off the power supply to the appliance (See Part 1, Section D).
2. Turn the front cover security latch.
3. Undo the two latches at the bottom of the cover (if applicable).
4. Remove the cover.

### B. PLACING THE APPLIANCE INTO NORMAL OPERATION

1. Replace the front cover in the normal position.
2. Close the security latch.
3. Turn on the power supply to the appliance.

To enter manual firing operation, enter SERVICE, in MODE—see Part 6, Section D

### C. TESTING THE MANUAL RESET HIGH LIMIT

The HOT™ Controls (.2 configuration), contain a unique function, they use both pressure transducers and temperature thermistors to monitor appropriate flow through the heat exchanger of the appliance. The .3 configuration uses a water flow switch. In both configurations, there are two high limit sensors, both are set through parameters, however, only one requires a manual reset when it is tripped, and often requires an annual test to confirm its proper operation.

To test the manual reset high limit:

1. Enter Setup menu, then enter the Password, then Test M R High Limit
2. Set the temperature you want the MHRL to open at, it will show the current setting as a default, you should select a temperature less than that to complete the test without overheating the hot water system, just push the down arrow until the appropriate temperature and then push ✓:

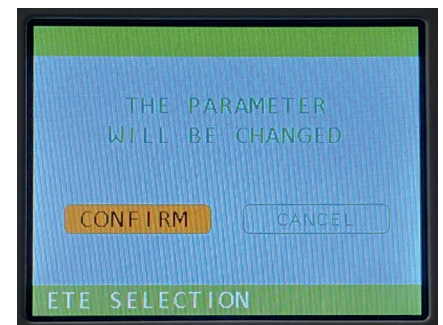
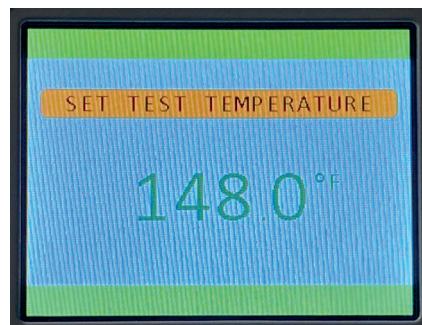
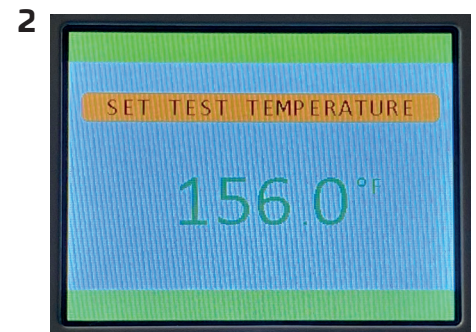
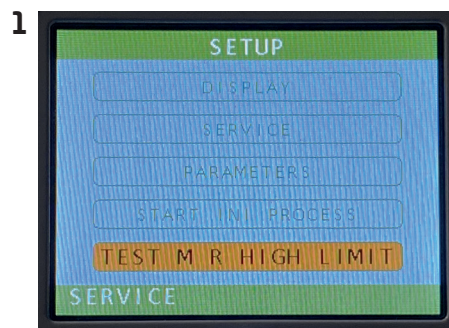

### C. TESTING THE MANUAL RESET HIGH LIMIT (continued)

3. The high limit test is only active for 10 minutes as a default, you can select a time less than that if desired, just push the down arrow until the appropriate time and then push  $\checkmark$ :

- The fact that the test is in progress will be indicated on the home screen scrolling message at the bottom, while it is active:
- You may also place the appliance in SERVICE MODE now to get the appliance to run at a higher firing rate and surpass the temporary MRHL setting sooner.
- When that setting is exceeded, the unit will shut down immediately and indicate a Hard Lock Out and H16 code. It will need to be reset to allow normal operation.
- Note that if you reset it right away and you have not reached the number of minutes you set for the test period and the temperature is now below your test setting and below your setpoint, it will run and likely trip again.

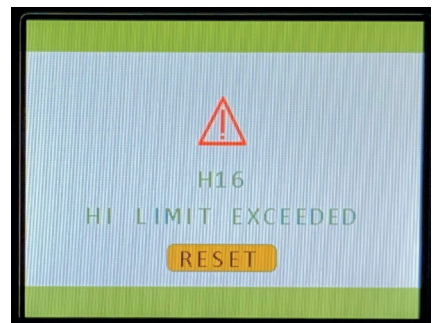
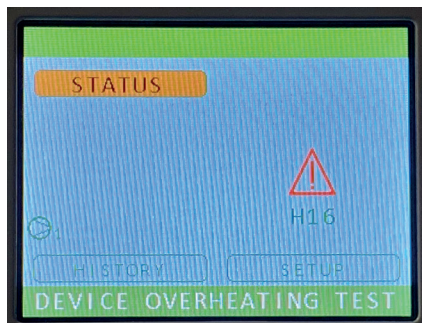
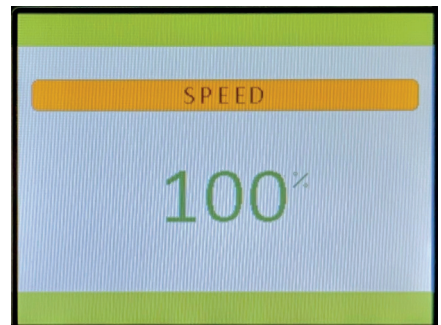
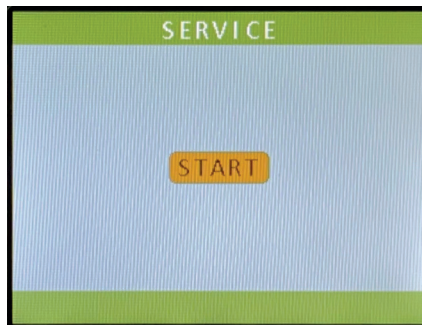
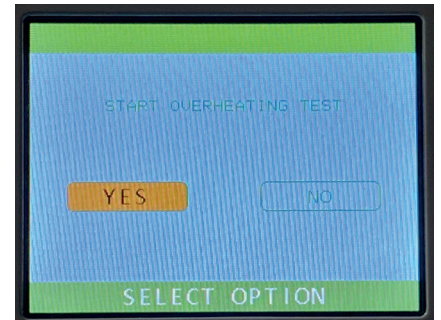
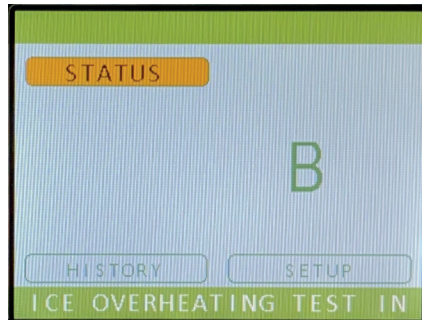
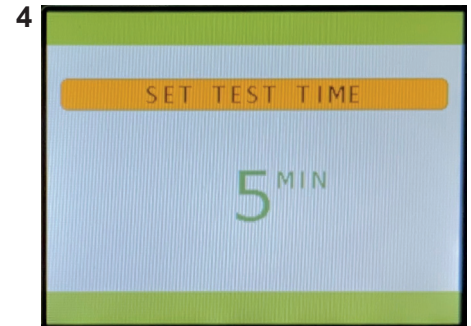
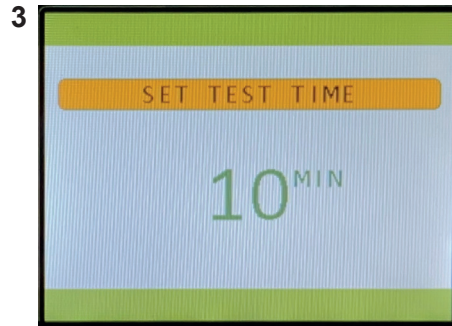

## D. SOFT LOCKOUT CODES (See Section 1, Part A for Sensor Locations and Uses)

**(TABLE 7-1) CCB SOFT LOCK OUT (SLO) CODES** 

Code	Cause	Recommended Action
CCB01	Sensor S1 fault	Check that the S1 sensor is connected
CCB02	Sensor S2 fault	Check that the S2 sensor is connected
CCB03	Sensor S3 fault	Check that the S3 sensor is connected
CCB04	Sensor S4/SZ1 fault	Check that the S4/SZ1 sensor is connected
CCB05	Sensor S5/SZ2 fault	Check that the S5/SZ2 sensor is connected
CCB06	Sensor S6 fault	Check that the S6 sensor is connected
CCB07	Sensor SZ3 fault	Check that the SZ3 sensor is connected
CCB08	Sensor zone 4 fault	Check that the zone 4 sensor is connected
CCB09	Sensor zone 5 fault	Check that the zone 5 sensor is connected
CCB10	Sensor zone 6 fault	Check that the zone 6 sensor is connected
CCB11	Sensor zone 7 fault	Check that the zone 7 sensor is connected
CCB12	Sensor zone 8 fault	Check that the zone 8 sensor is connected
CCB15	Communication error via Modbus programming	Quantity of programmed appliances does not match quantity of connected appliances.
CCB20- CCB27	Communication error with a specific appliance; A = CCB 20... H = CCB 27	Check specific appliance to see that it is powered on, if yes, then check all communication connections at display and main boards
CCB200	EEPROM fault	Check that the EEPROM is connected properly

**(TABLE 7-2) BCB SOFT LOCK OUT (SLO) CODES** 

\*Codes may appear with an A, B, or C as a suffix denoting the number of times the code has appeared since the last Initialization (INI). Some SLO's are accompanied by a reduction of the maximum firing rate; A=80%, B=50%, C=30%. After the C suffix appears, the next code of that kind becomes an HLO (manual reset required).

Code	Cause	Recommended Action
A1*	Excessive pressure differential ( $\Delta P$ ) on water side of heat exchanger	Check for scaling or blockage on water side of heat exchanger, also check pump performance. If this SLO is indicated while the unit is firing, it is doing so at a reduced BTU input; low enough to stay below that maximum $\Delta P$ set point.
B01	Pressure too high at condensate drain connection during Stand By	Look for condensate backing up into combustion side of heat exchanger.
B02	Pressure too high at condensate drain connection during pre-purge	Insure condensate drain system is flowing freely, and vent is clear of obstructions. Also, be sure the Z-INI has been initiated.
B03	Pressure too low at condensate drain connection during pre-purge	Check for condensate (water) in the condensate neutralizer (if equipped) or the condensate trap at appliance outlet. If it is dry, add water to form trap. The appliance also will initiate an auto-filling process for the condensate trap, indicated on the screen during this operation. Also, be sure the Z-INI has been initiated.
B04	Pressure at flue/condensate sensor is too low	Check flue gas vent connection or sensor connection located at condensate drain line. Also check for a disconnected or open condensate drain line and last, look for a leak in the heat exchanger outer casing (behind the insulation).
DW7*	Temperature rise ( $\Delta T$ ) through heat exchanger is too high	Unit is operating at a reduced BTU input - check for scaling or blockage on water side of heat exchanger, also check pump performance.
FL05*	Flue gas temperature too high	Unit is burning at a reduced BTU input rate. The cause of the high flue gas temperature should be investigated and corrected ASAP
FL09*	Fouling of the fire side of the heat exchanger	Unit is burning at a reduced BTU input rate. A combustion side inspection and cleaning should be scheduled ASAP.
FL13	Flue gas sensor (T5) fault (not connected or open status)	Check the condition of the connectors and wires from the card edge connector at the board to the flue gas sensor on the appliance.
FL14	Flue gas sensor (T5) fault (short circuit status)	Take an OHM reading at the connector on the flue gas sensor - compare it to the chart in Part 7, Section I, replace if out of range.
G01*	Gas supply pressure too low	If this occurs at the beginning of an ignition cycle, this SLO will stay until the pressure is high enough for proper ignition. If this occurs while the unit is firing, and it continues to fire, it is doing so at a reduced BTU input low enough to stay above that minimum pressure set point.
H01	Outlet sensor (T1.1, 1.2) fault (not connected or open status)	Check the condition of the connectors and wires from the card edge connector at the board to the outlet sensor on the appliance.
H02	Inlet sensor (T2) fault (not connected or open status)	Check the condition of the connectors and wires from the card edge connector at the board to the inlet sensor on the appliance.
H04	Outlet sensor (T1.1, 1.2) fault (short circuit status)	Take an OHM reading on the outlet sensor - compare it to the chart in Part 7, Section I, replace if out of range.

## D. SOFT LOCKOUT CODES (continued)

(TABLE 7-2) BCB SOFT LOCK OUT (SLO) CODES  (continued)

Code	Cause	Recommended Action
H05	Inlet sensor (T2) fault (short circuit status)	Take an OHM reading on the inlet sensor - compare it to the chart in Part 7, Section I, replace if out of range.
H07/09	Calibration between inlet (T2) and outlet (T1) water temperature sensors indicates too great a differential.	Test both sensors against the actual temperature and OHMs as shown in the chart in Part 7, Section I, replace as required. The appliance will continue to operate, but at a reduced input until the required correction has been resolved.
H11	High $\Delta T$	See Part 7, Section F
H24*	High Limit set point has been exceeded	Appliance restarts, but at a reduced input; after 3 restarts, the appliance gets a Manual Lock Out (HLO) and needs the cause resolved immediately. Possible causes are high $\Delta T$ , temperature setpoint versus high limit setting too close or bad sensor.
ID01	First INI process data missing	Run the Z-INI; starting Initialization numbers must be tested and the saved for all connected sensors in a number of conditions.
ID02	EMB EEPROM fault (2)	Reset the fault, cycle power on and off, if the fault reappears, the EMB-EEPROM is corrupted.
ID03	EMB EEPROM fault (1)	Reset the fault, cycle power on and off, if the fault reappears, the EMB-EEPROM is corrupted.
ID04	Internal fault (gv1)	Reset the fault, cycle power on and off, if the fault reappears, the EMB-EEPROM is corrupted.
ID05	Internal fault (gv2)	Reset the fault, cycle power on and off, if the fault reappears, the EMB-EEPROM is corrupted.
ID06	Internal fault (gv3)	Reset the fault, cycle power on and off, if the fault reappears, the EMB-EEPROM is corrupted.
ID09	Fan speed error	Cycle power off, check the four-wire fan connection; wires and each end at connectors. If all ok, cycle power back on and if fan Speed error reappears, replace fan.
ID11	Flame proof indicated without flame present	Cycle power off, check Igniter, Ignition cable and cable ends, if moisture present, dry thoroughly. Cycle power back on.
ID13	Low voltage to appliance	Check voltage - this fault occurs when the supply voltage is more than 10% less than rated supply.
ID14	High voltage to appliance	Check voltage - this fault occurs when the supply voltage is more than 15% greater than rated supply.
ID16 A	External sensor (T6) fault (not connected or open status)	Check the condition of the connectors and wires from the card edge connector at the board to the terminal strip to the external sensor in the piping or Low Loss Header.
ID16 B	External sensor (T6) fault (short circuit status)	Take an OHM reading on the wires from the external sensor in the piping or low loss header - compare it to the chart in the Part 7, Section I, replace if out of range.
ID19 A	Tank sensor (T3) fault (not connected or open status)	Check the condition of the connectors and wires from the card edge connector at the board to the terminal strip to the storage tank sensor.
ID19 B	Tank sensor (T3) fault (short circuit status)	Take an OHM reading on the wires from the storage tank sensor - compare it to the chart in Part 7, Section I replace if out of range.
ID20 A	Outdoor sensor (T4) fault (not connected or open status)	Check the condition of the connectors and wires from the card edge connector at the board to the terminal strip to the outdoor air sensor.
ID20 B	Outdoor sensor (T4) fault (short circuit status)	Take an OHM reading on the wires from the outdoor air sensor - compare it to the chart in Part 7, Section I, replace if out of range.
ID80	Boiler is configured for cascade, but no cascade manager present	Check settings in individual appliance parameter S25; should be a different value in each appliance between A-H. <b>NOTE:</b> There should not be a SET POINT option available on the home screen of the appliance if S25 is set properly.
ID87	Actual fan speed is lower than specified fan speed, during speed up.	The appliance is waiting to allow the fan time to reach the required rpm, if it does not achieve it in 30 seconds, ID88 will become the new fault code.
ID88	Actual fan speed did not reach required rpm in the time allotted.	If the actual fan speed is more than +/- parameter F20 rpm off the set fan speed after pre-purge time ID88 is shown. This fault will correct itself after the correct fan speed is achieved.
ID89	T1.1-T1.2 $\Delta T$ fault	The $\Delta T$ on the duplex outlet sensor (T1.1 & T1.2) is greater than 18°F. Test both sensors against the actual temperature and OHMs as shown in the chart in Part 7, Section I, replace as required.
ID95	EEPROM key blank	EEPROM key is blank with no data
ID97	EEPROM key missing	EEPROM key is not connected or not communicating
P04*	No water flow from the pump	Check for pump electrical issues i.e. no power to the pump, pump motor is seized, pump is constantly powered and running.
P05*	Reduced water flow through appliance	Check for partially closed valves, pump impeller fouling etc. Appliance is operating at a reduced BTU capacity to avoid heat exchanger damage.
S13	Additional safety fault	Check the status of the additional safety input switch when call for heat is established, and P7 time elapsed, and continuously thereafter during a burn cycle.
W01*	Maximum water pressure exceeded	Water pressure too high (within 10% of pressure relief valve rating), confirm cause and correct. Unit is operating at a reduced BTU capacity to try and avoid the relief valve opening.
W04*	Water pressure is less than minimum setting	Water pressure too low (within 10% of minimum pressure required), confirm cause and correct. Unit is operating at a reduced BTU capacity to try and avoid any damage to the heat exchanger.

## E. APPLIANCE HARD LOCKOUT CODES

(TABLE 7-3) BCB HARD LOCKOUT (HLO) CODES



Code	Cause	Recommended Action
A1/A2	Excessive pressure differential ( $\Delta P$ ) on water side of heat exchanger	Check for scaling or blockage on water side of heat exchanger, also check pump performance.
B03	Neutralizer/trap has little or no Condensate (water)	Fill neutralizer (or trap if not a factory neutralizer) with water to avoid flue gases spilling into the room through a dry trap.
B04	Pressure at flue/condensate sensor is too low	Check flue gas vent connection or sensor connection located at condensate drain line. Also check for a disconnected or open condensate drain line and last, look for a leak in the heat exchanger outer casing (behind the insulation).
DW7	Temperature rise ( $\Delta T$ ) through heat exchanger is too high	Appliance has been through multiple tests and checks including operating at a reduced input to avoid this shut down. The $\Delta P$ across the heat exchanger indicates reduced water flow. Check the pump performance, check for partially closed valves and if all ok, perform a descaling operation on the water side of the heat exchanger.
FL01	Flue gas temperature has exceeded the maximum safe level set in the operating parameters	Flue gas temperature setting has been exceeded by a significant amount even after operation at a reduced firing rate. Check entire burner assembly, if ok, then a complete fire side cleaning must be initiated immediately.
FL05	Flue gas temperature too high	Unit is burning at a reduced BTU input rate. The cause of the high flue gas should be investigated and corrected ASAP—See FL01
FL09	Fire side of heat exchanger is severely fouled	Remove burner and check condition of fire side of tubes in the burner area.
G01	Gas pressure too low	Find cause of low pressure and correct; piping or regulator sizing is the general culprit
G03	Gas pressure too high during a burn cycle	Correct the cause of the high gas pressure - either adjust regulator or replace and repair as required - maximum allowed by code is 14" w.c.
H15/H16	Water temperature limit set point exceeded	Check set point(s), sensors, pumping etc. Correct cause of high water temperature
H24	Water Temperature Manual Reset High Limit set point exceeded	Check set point(s), sensors, pumping etc. Correct cause of high water temperature
ID01	First INI process data missing	Run the Z-INI; starting Initialization numbers must be tested and the saved for all connected sensors in a number of conditions.
ID02	EMB EEPROM fault (2)	Reset the fault, cycle power on and off, if the fault reappears, the EMB-EEPROM is corrupted.
ID03	No valid data on microcontroller Flash memory	Reset the fault, cycle power on and off, if the fault reappears, the EMB-EEPROM is corrupted.
ID04	Internal fault (gv1)	Reset the fault, cycle power on and off, if the fault reappears, the EMB-EEPROM is corrupted.
ID05	Internal fault (gv2)	Reset the fault, cycle power on and off, if the fault reappears, the EMB-EEPROM is corrupted.
ID06	Internal fault (gv3)	Reset the fault, cycle power on and off, if the fault reappears, the EMB-EEPROM is corrupted.
ID09	Fan speed error	Cycle power off, check the four-wire fan connection; wires and each end at connectors. If all ok, cycle power back on and if fan Speed error reappears, replace fan.
ID12	Flue thermostat open.	Check for open flue temperature switch, if parameter S24=1
ID89	Fan is not running	Either fan is not running (check wiring or replace), or factory programming has been altered (consult factory).
ID96	Wrong EEPROM key connected	Install proper EMB EEPROM, if it cannot be found, contact the factory for assistance - be sure to have model and serial number of the appliance in question.
ID99	BDB Reset action finished	There have been too many resets, a concerted effort must be made to find the cause of the fault and correct it. This is a timed action, and the unit cannot be reset until the time has elapsed. Contact the factory with further questions. This fault will require both a power reset and then an on-screen fault reset via the HISTORY tab.
IG2/IG3	Too many restarts or relights after no-flame.	Appliance has been through multiple tests and checks including trying to ignite at different inputs to avoid this shut down. Combustion related items must be checked, including air/gas ratio, ignition cable and igniter. Check flow switch if installed.
IG4/IG5	Too many restarts or relights after no-flame.	Appliance has been through multiple tests and checks including trying to ignite at different inputs to avoid this shut down. Combustion related items must be checked, including air/gas ratio, ignition cable and igniter. Check flow switch if installed.
IG19	Too many attempts for ignition	Appliance has been through multiple tests and checks including trying to ignite at different inputs to avoid this shut down. Combustion related items must be checked, including air/gas ratio, ignition cable and igniter. Check flow switch if installed.
IG27	Too many attempts for ignition	Appliance has been through multiple tests and checks including trying to ignite at different inputs to avoid this shut down. Combustion related items must be checked, including air/gas ratio, ignition cable and igniter. Check flow switch if installed.
P04	Low or no water flow	Check for pump electrical issues i.e. no power to the pump, pump motor is seized, pump is constantly powered and running.
S13	Additional safety circuit (terminals 20, 21) open	Check flow switch, burner door and heat exchanger rear wall high temperature limits

**(TABLE 7-3) BCB HARD LOCKOUT (HLO) CODES**  **(continued)**

Code	Cause	Recommended Action
P05	Water flow too low through appliance	Check for partially closed valves, pump impeller fouling etc.
P06	Water flow blocked during a burn cycle (proof of flow)	Check for partially closed valves, pump impeller fouling etc.
W04	Minimum water pressure	Water pressure too low (within 10% of minimum pressure required), confirm cause and correct.

**NOTE:** In many cases, a “hard lockout” will indicate that there is something wrong with the appliance, that should be serviced or repaired.

**EXAMPLE:**

If there is a loss of flow due to an air bubble passing through the appliance (sensed via the water pressure transducers), the appliance will shut down and display a temporary fault of P04 or P05 A, B, or C. When flow resumes and a waiting time has elapsed, the control board will perform a pre-start diagnostic and then resume a burn cycle.

**F. TO TURN OFF GAS TO THE APPLIANCE**

1. Set the thermostat to lowest setting.
2. Turn off power switch on front of unit.
3. Turn off all electric power to the appliance if service is to be performed.
4. Turn gas shutoff valve clockwise to “off.” Handle will be horizontal. Do not force.

**G. PUMP & WIRING CONTROL**

The appliance control board has an on-board relay for controlling the circulating pump. On a call for heat, the pump will start, allowing the water flow proving circuit to be made and the pre-start diagnostic to continue. After the call for heat has been satisfied, the pump will continue to run for the factory programmed period of time (1 minute) and then shut off. For water heating applications an external temperature sensor must be mounted in the water storage tank. For heating applications, the call for heat must come from an external source (room thermostat etc.).

## H. STATUS READINGS

(FIGURE 7-4) STATUS READING INSTRUCTIONS

OUTLET SENSOR-T1	73.0 °F
INLET SENSOR-T2	72.6 °F
EXHAUST SENSOR-T5	69.2 °F
EXTERNAL SENSOR-T6	--- °F
HX OUTLET SENSOR-TR5	0.16 IWC
INLET GAS SENSOR-TR2	9.62 IWC
FAN OUTLET SENSOR-TR1	0.00 IWC

TEMPERATURE THERMISTORS

WATER SENSOR OUT-TR4	19.72 PSI
WATER SENSOR IN-TR3	19.00 PSI
SET FAN SPEED	0 %
ACTUAL FAN SPEED	0 RPM
PUMP SPEED	0 %
FLAME IONIZATION	0.02 UA

TEMPERATURE THERMISTORS

Sensor list and other details on screens will vary from system to system

## I. APPLIANCE SENSOR RESISTANCE TABLE

(TABLE 7-5)

TEMPERATURE (°F)	RESISTANCE (OHM)	TEMPERATURE (°C)	RESISTANCE (OHM)
32	32550	0	32550
41	25340	5	25340
50	19870	10	19870
59	15700	15	15700
68	12490	20	12490
77	10000	25	10000
86	8059	30	8059
95	6535	35	6535
104	5330	40	5330
113	4372	45	4372
122	3605	50	3605
131	2989	55	2989
140	2490	60	2490
149	2084	65	2084
158	1753	70	1753
167	1481	75	1481
176	1256	80	1256
185	1070	85	1070
194	915	90	915
203	786	95	786

## PART 8. MAINTENANCE

### A. PERIODIC MAINTENANCE AND INSPECTIONS

All high efficiency condensing appliances will require more regular maintenance (cleaning) than their non-condensing counterparts. Failure to do so may result in damage to the appliance that is not covered under warranty. Failure to follow all of the instructions contained in this manual may also cause premature product failure that may not be covered under warranty.

Periodic maintenance should be performed at least once a year by a qualified service technician to ensure

that all the equipment is in safe, efficient operation. ***Failure to do so may eliminate warranty coverage.*** In the first year of operation, it is highly recommended that inspections of all connection points and the combustion chamber be done at three month intervals, any signs of fouling or leaks must be thoroughly investigated immediately as failure to do so may void warranty. Assuming no cause for excessive fouling is found, then the period of months from initial start up that it was found that cleaning was

required, shall become the required future minimum cleaning interval, but at no time should it exceed 12 months. The owner **MUST** make necessary arrangements with a qualified heating contractor for proper maintenance of the appliance. Installer must also inform the owner that the lack of proper care and maintenance of the appliance may result in a hazardous condition and lack of warranty coverage. The installer should discuss the contents of the User's Information Manual with the owner.

**B. ANNUAL INSPECTION** (See LIT91179 Maintenance Checklist for required tools and materials)

An inspection should cover, at a minimum, the following areas:

- Inspect all fittings, controls and connections for leaks, damage, or fouling
- Fire side:
  - Heat exchanger
  - Burner and ignitor
  - Burner door and rear wall insulation
- Drain system components:
  - Hoses & clamps
  - Trap assembly
  - Condensate neutralizer
- Test all safeties and operating controls
- Water side temperature rise ( $\Delta T$ ) test

**INSPECTION AND CLEANING**

**CAUTION:** Before removing the door of the appliance, switch off the electrical power supply to it.

- Remove the front cover and check the sensors, transducers, all pipes, lines and connections, and the heat exchanger (top, bottom) for traces of water and water leakage.
- Inspect the top of the casing and/or the top of the appliance for water leakage or traces of water from the air supply pipe or the air vent (if applicable).

### C. HEAT EXCHANGER ANTI-SCALING PREVENTION FEATURE

The appliance controller contains sophisticated software that enables it to monitor the rate of temperature rise through the heat exchanger. By doing this, it greatly reduces the possibility of heat exchanger failure due to scaling or fouling. A set of parameters are programmed in at the factory, to provide a design temperature rise ( $\Delta T$ ) setting on each size unit that is fixed. The Anti-Scale is based on an increase over the design  $\Delta T$  through the heat exchanger. This Anti-Scale is determined using the inlet and outlet sensors, even if a tank thermistor is being

used. If the Anti-Scale setting is reached, the unit will display H11, shut down and not re-fire until it has cooled. The first 3 times this happens, there will be a reduction of the maximum firing rate. The fault will be accompanied by either an A, B, or C suffix, indicating a maximum firing rate of 80%, 50%, or 30% respectively. The control will go into hard Lockout after the C suffix is achieved, and have to be manually reset. Once the heat exchanger has been acid cleaned, contact the factory for instructions on resetting the unit for full rated BTU input.

Typical causes for repeated H11 indications at start up are air trapped in the heat exchanger or contaminates lodging in the piping or heat exchanger during installation, both of these causes can generally be cleared by isolating the hot water system and flushing water at full city pressure through the drain valve or relief valve on the appliance outlet.

## PART 9. SPECIAL INSTALLATION REQUIREMENTS

### A. INSTALLATION REQUIREMENTS—MASSACHUSETTS

#### Requirements for installation—Commonwealth of Massachusetts

For all side wall horizontally vented gas fueled equipment installed in every dwelling, building or structure used in whole or in part for residential purposes, including those owned or operated by the Commonwealth and where the side wall exhaust vent termination is less than seven (7) feet above finished grade in the area of the venting, including but not limited to decks and porches, the following requirements shall be satisfied:

1. **INSTALLATION OF CARBON MONOXIDE DETECTORS.** At the time of installation of the side wall horizontal vented gas fueled equipment, the installing plumber or gasfitter shall observe that a hard wired carbon monoxide detector with an alarm and battery back-up is installed on the floor level where the gas equipment is to be installed. In addition, the installing plumber or gasfitter shall observe that a battery operated or hard wired carbon monoxide detector with an alarm is installed on each additional level of the dwelling, building or structure served by the side wall horizontal vented gas fueled equipment. It shall be the responsibility of the property owner to secure the services of qualified licensed professionals for the installation of hard wired carbon monoxide detectors.
  - a. In the event that the side wall horizontally vented gas fueled equipment is installed in a crawl space or an attic, the hard wired carbon monoxide detector with alarm and battery back-up may be installed on the next adjacent floor level.
  - b. In the event that the requirements of this subdivision can not be met at the time of completion of installation, the owner shall have a period of thirty (30) days to comply with the above requirements; provided, however, that during said thirty (30) day period, a battery operated carbon monoxide detector with an alarm shall be installed.
2. **APPROVED CARBON MONOXIDE DETECTORS.** Each carbon monoxide detector as required in accordance with the above provisions shall comply with NFPA 720 and be ANSI/UL 2034 listed and IAS certified.
3. **SIGNAGE.** A metal or plastic identification plate shall be permanently mounted to the exterior of the building at a minimum height of eight (8) feet above grade directly in line with the exhaust vent terminal for the horizontally vented gas fueled heating appliance or equipment. The sign shall read, in print size no less than one-half (1/2) inch in size, "GAS VENT DIRECTLY BELOW. KEEP CLEAR OF ALL OBSTRUCTIONS".
4. **INSPECTION.** The state or local gas inspector of the side wall horizontally vented gas fueled equipment shall not approve the installation unless, upon inspection, the inspector observes carbon monoxide detectors and signage installed in accordance with the provisions of 248 CMR 5.08(2)(a)1 through 4.
  - a. **EXEMPTIONS:** The following equipment is exempt from 248 CMR 5.08(2)(a)1 through 4:
    1. The equipment listed in Chapter 10 entitled "Equipment Not Required To Be Vented" in the most current edition of NFPA 54 as adopted by the Board; and
    2. Product Approved side wall horizontally vented gas fueled equipment installed in a room or structure separate from the dwelling, building or structure used in whole or in part for residential purposes.

## B. INSTALLATION AT HIGH ALTITUDES

This appliance is equipped with an automatic combustion characteristic adjustment system, provided the installed elevation above sea level is entered into the operating control when the elevation is greater than 2,000 feet and less than or equal to 9,000 feet.

For elevations above 9,000 feet, set the maximum altitude allowable and set combustion as normal.

These appliance's have been operating at elevations up to 16,500 feet above sea level on LP gas; for more than 15 years utilizing these settings and a special burner and burner door that must be factory installed and tested during production.

To enter the operating elevation:

- From the setup menu, enter the password for the installer level or higher. Enter the parameters menu, then the altitude parameter set. Enter the appropriate elevation for the installation.
- The adjusted altitude entered is internally converted to an offset on top of the maximum fan speed.

- ***By adjusting the combustion characteristics as described above, there is no de-rate required at altitudes up to 9,000 feet. For elevations in excess of 9,000 feet or gas BTU content levels below 950 BTU/cubic foot, consult the factory at 800.968.5530 for adjustments and de-rating information.***

**(TABLE 8-1) MAX  $\Delta P$**

Model	Air Pressure ( $\Delta P$ )
HW 800	0.68" wc
HW 1000	0.88" wc
HW 1500	1.64" wc

# PART 10. PARTS BREAKDOWN

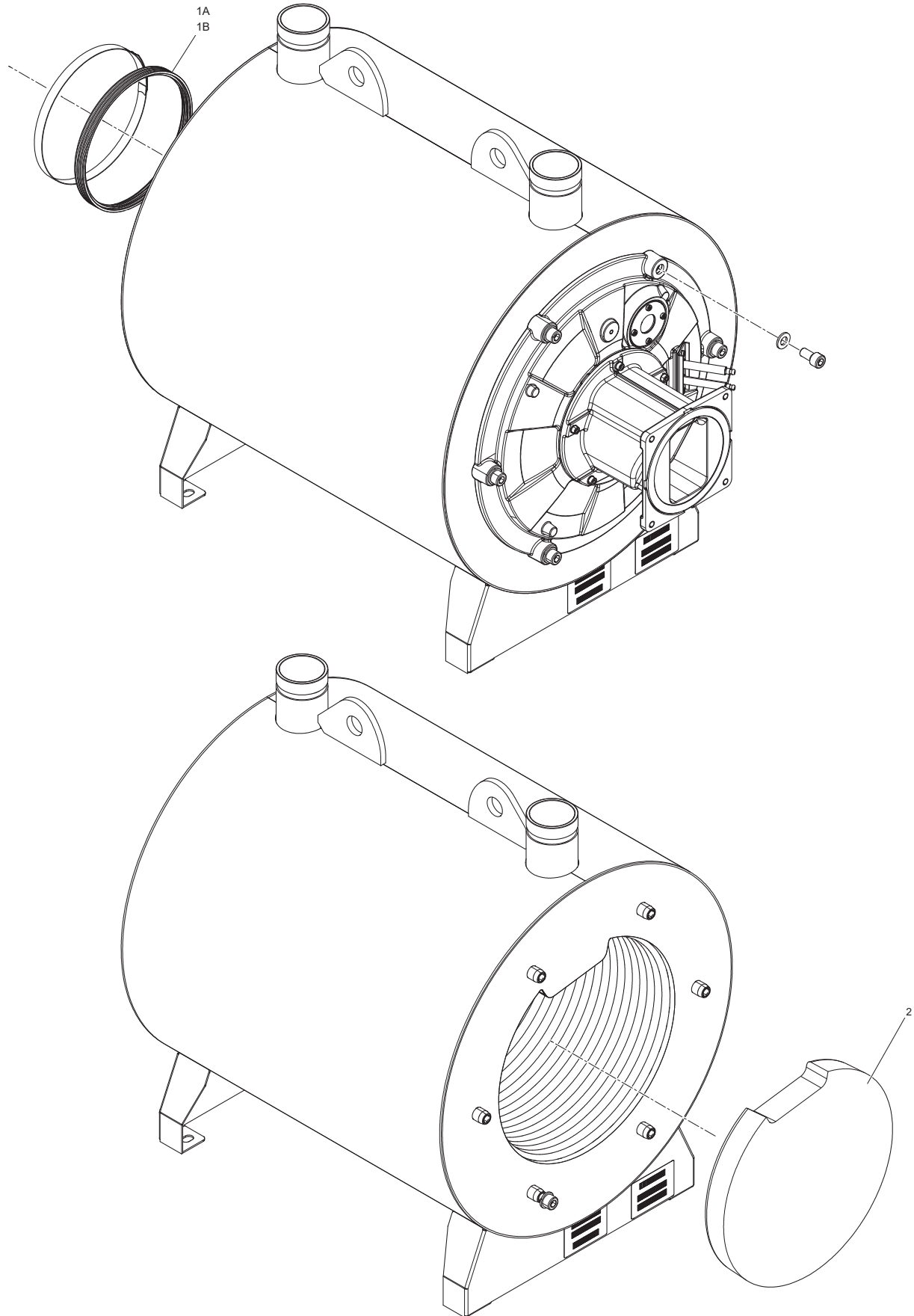

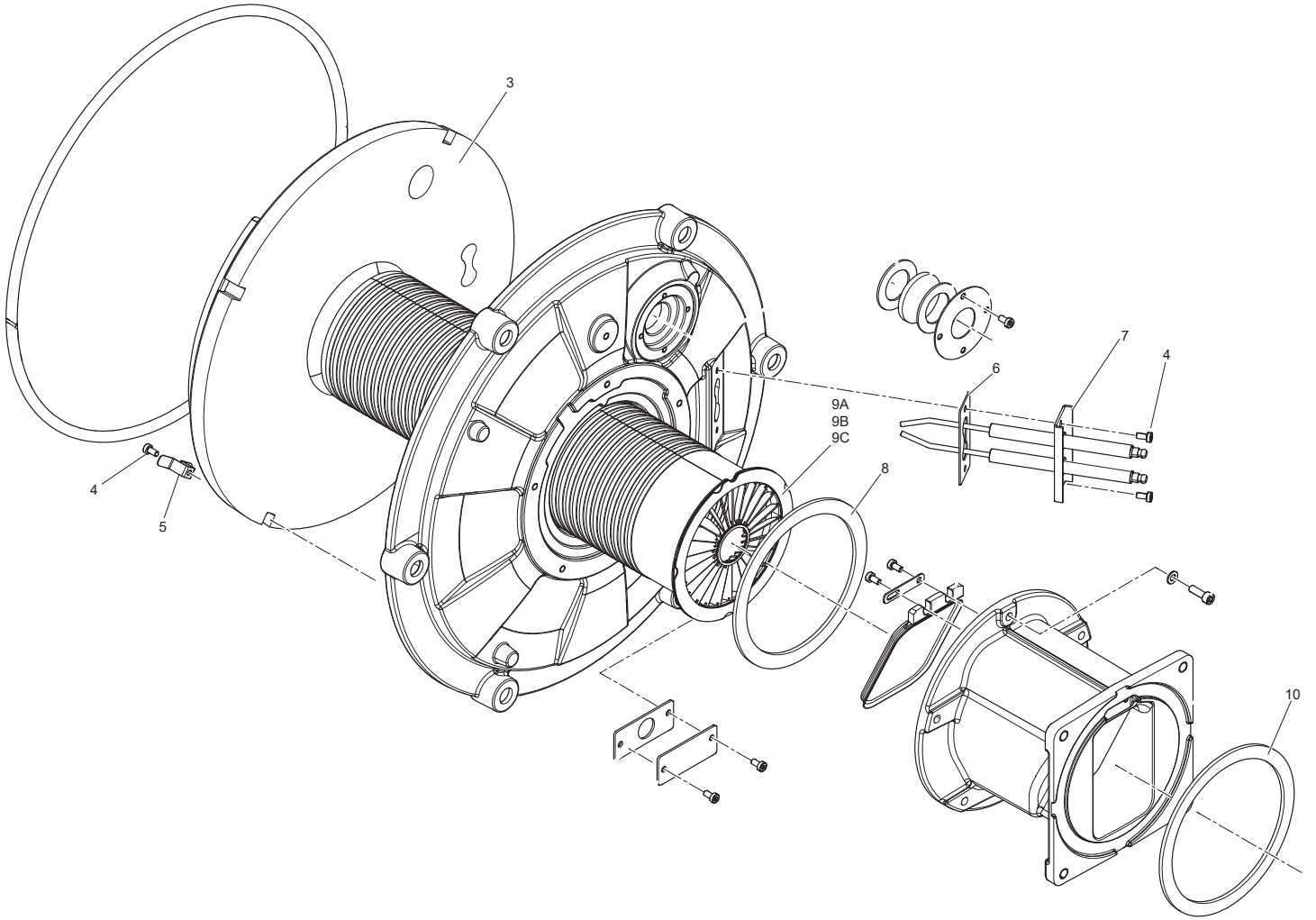

## HX SPARE PARTS

ITEM	PART NUMBER	DESCRIPTION	QUANTITY PER HX
1A	D146956	8" Flue Exit Gasket (1.5M)	1
1B	D146957	6" Flue Exit Gasket (800K & 1M)	1
2	D146958	Heat Exchanger Insulation (800K, 1M, 1.5M)	1
3	D146959	Burner Door Insulation (800K, 1M, 1.5M)	1
4	D146960	Screw (M4x8)	14
5	D146961	Buner Door Insulation Clip	4
6	D146962	Ignition Electrode Gasket	1
7	D146963	LNHEXT Ignition Electrode	1
8	D146964	Burner Gasket (800K, 1M, 1.5M)	1
9A	D146965	Bluejet Burner (800K)	1
9B	D146966	Bluejet Burner (1M)	1
9C	D146967	Mesh Burner (1.5M)	1
10	D146968	Intake Manifold Gasket (800K, 1M, 1.5M)	1
	D133303	800K Complete HX 'H'	
	D153055	800K Complete HX 'H'	
	D133304	1000M Complete HX 'H'	
	D153056	1000M Complete HX 'HLW'	
	D133305	1500M Complete Hx 'H'	
	D153057	1500M Complete HX 'HLW'	

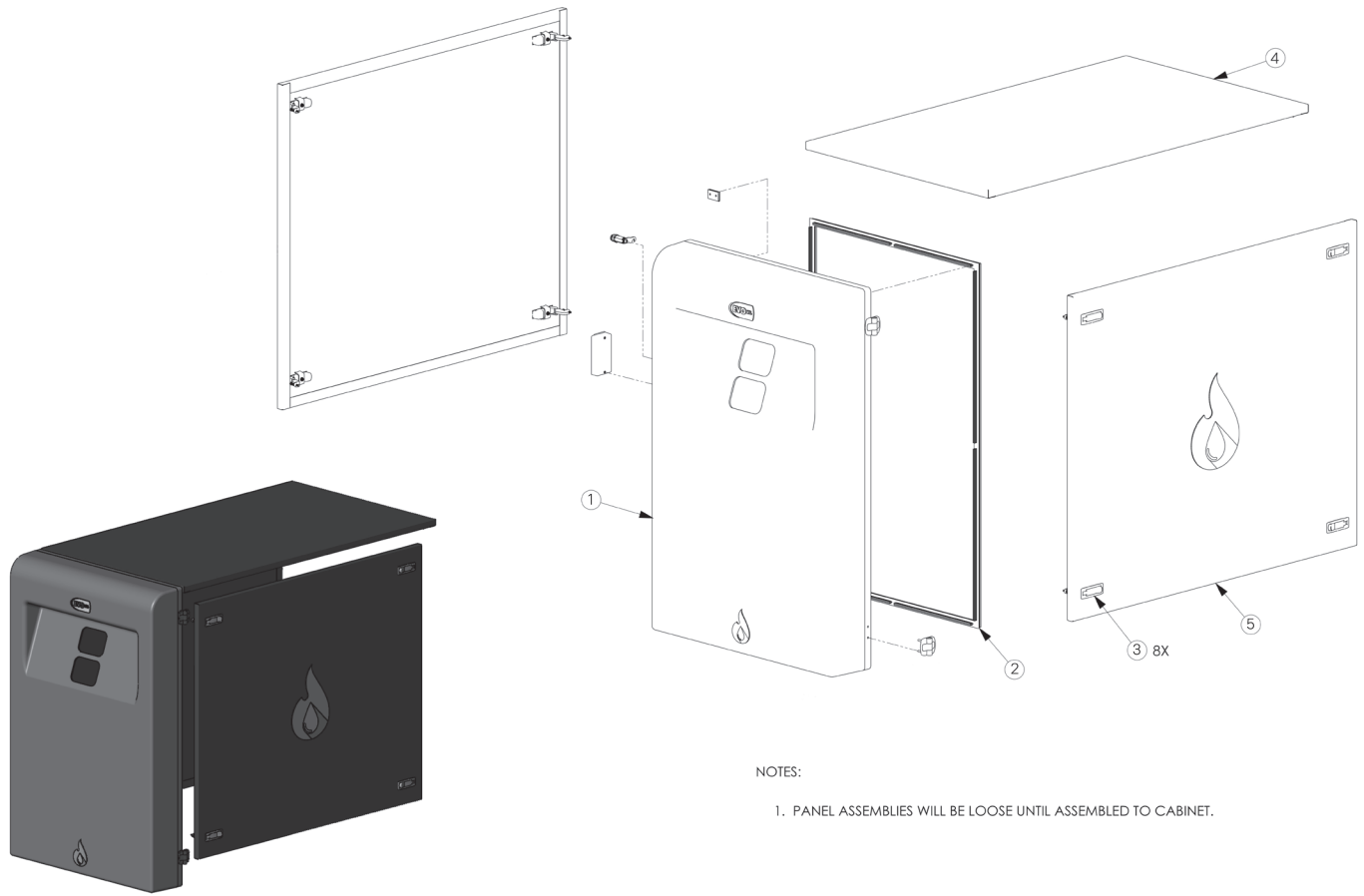

NOTES:

1. PANEL ASSEMBLIES WILL BE LOOSE UNTIL ASSEMBLED TO CABINET.

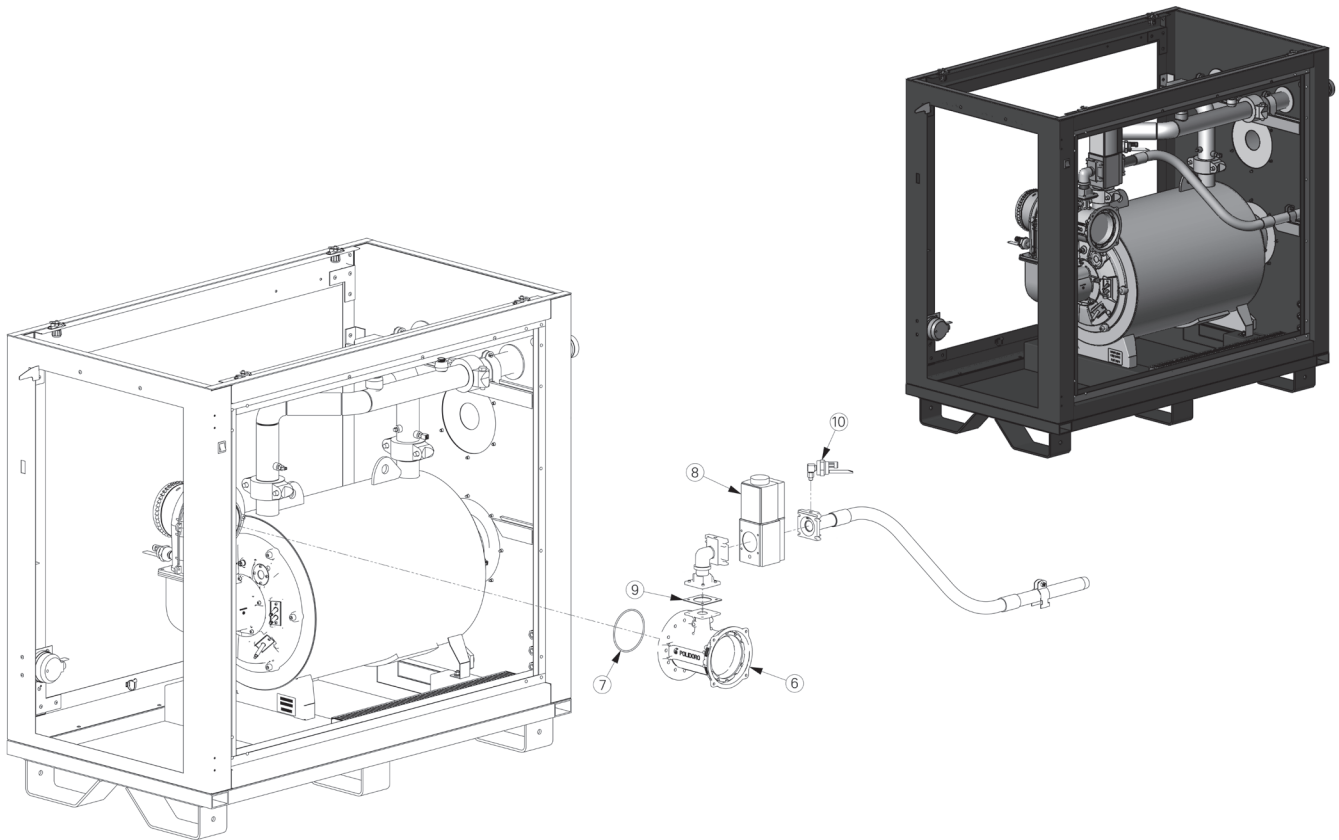

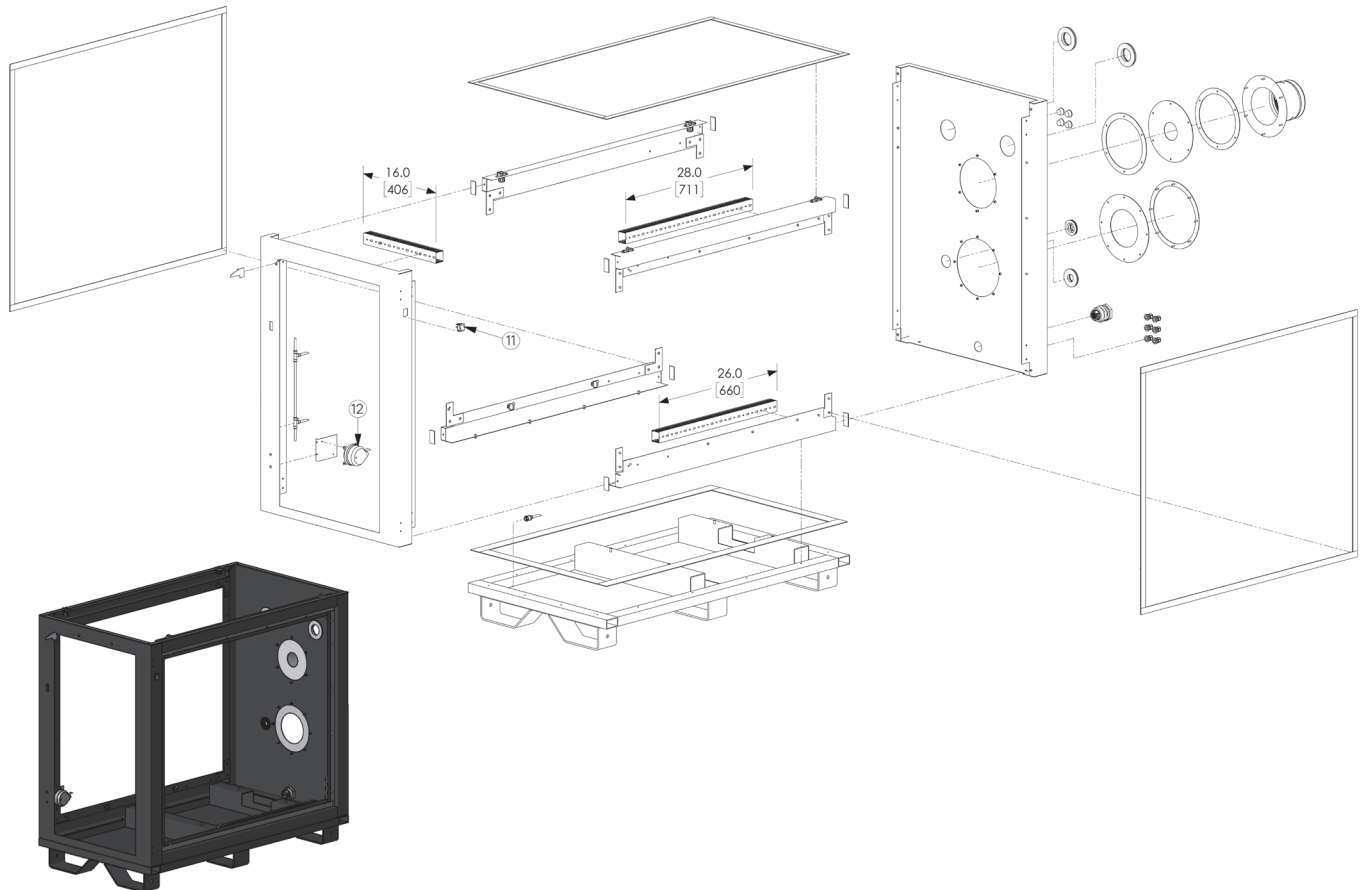
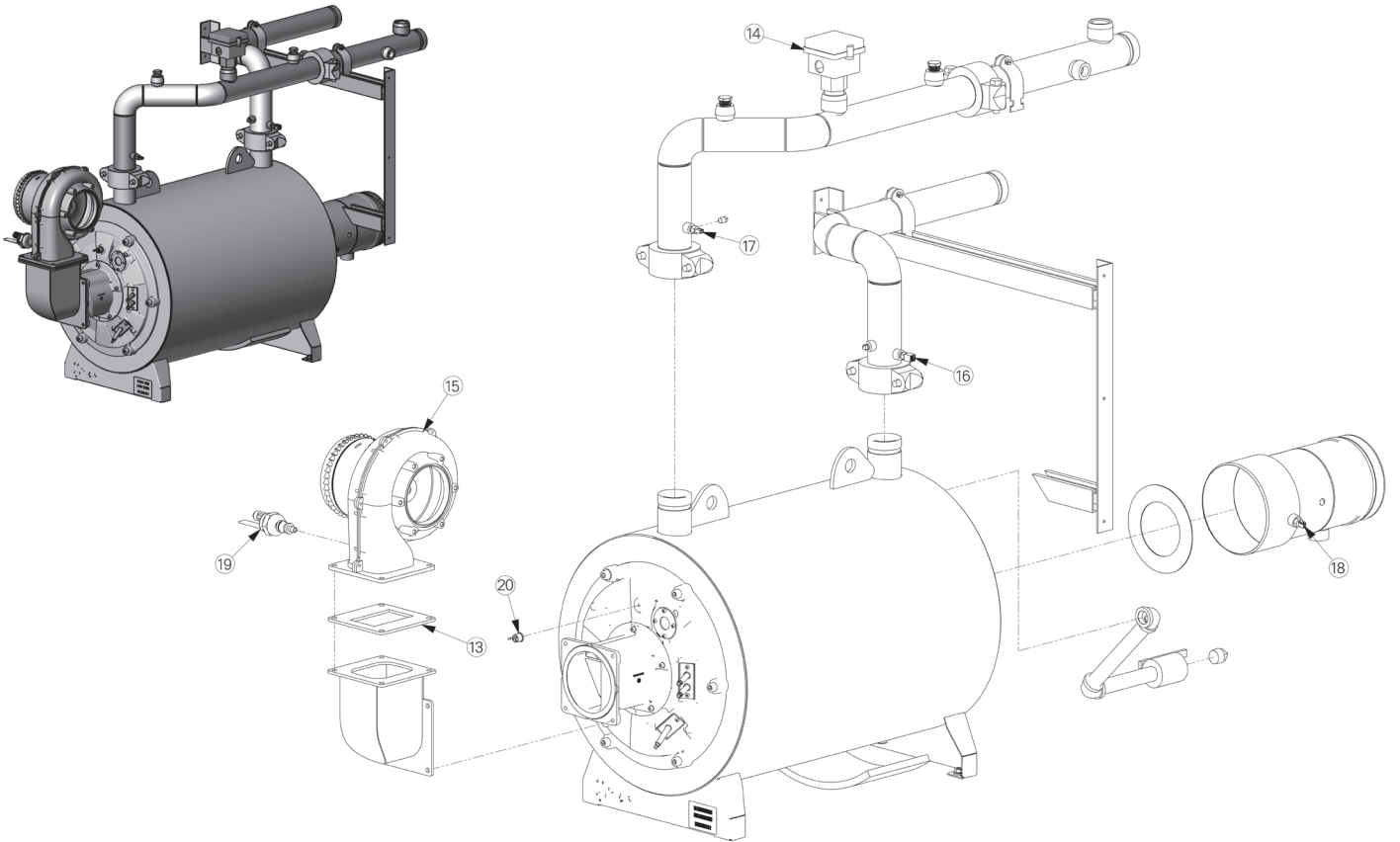

## PART 10. PARTS BREAKDOWN: SIDE PANEL

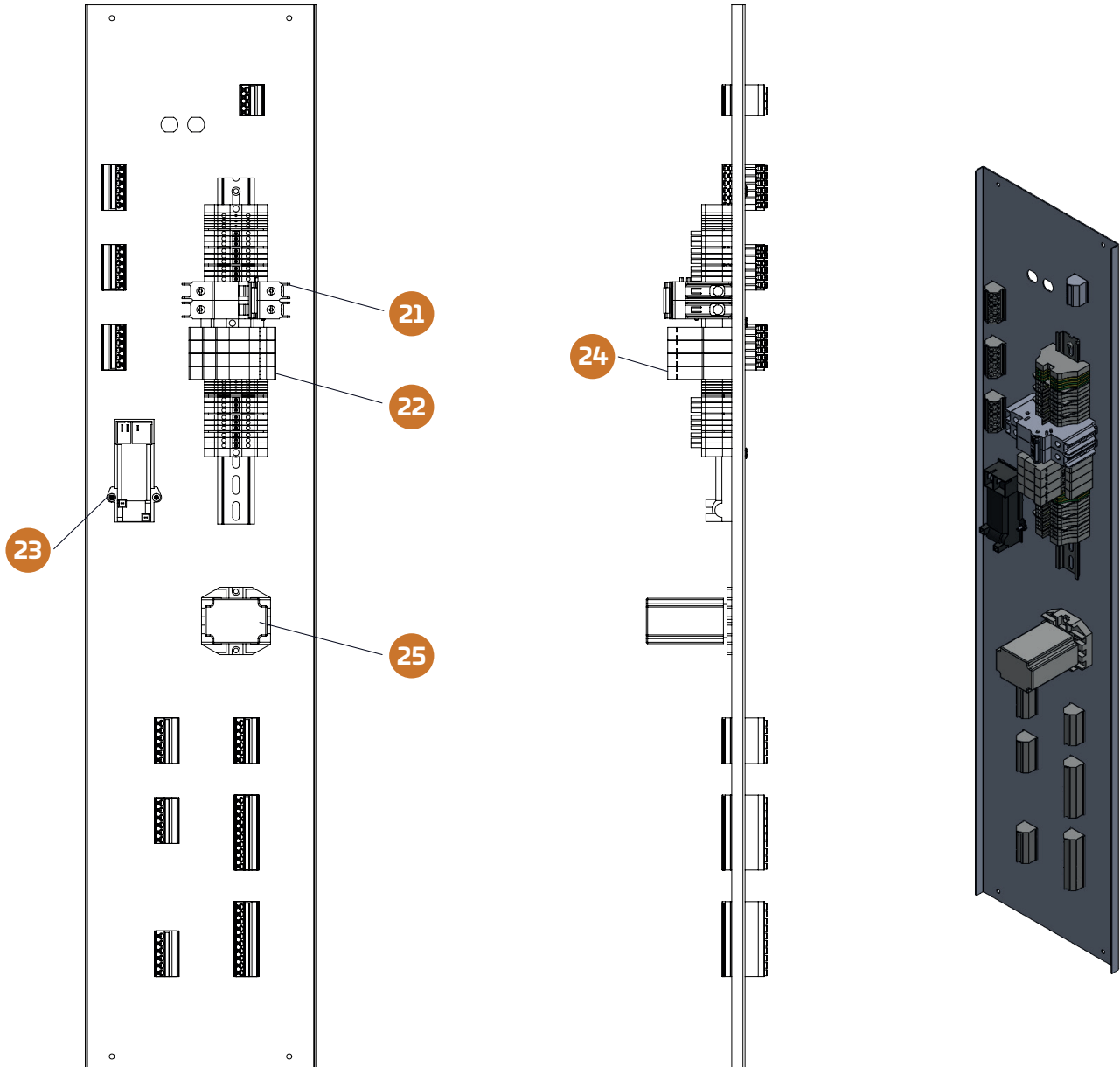

# PART 10. PARTS BREAKDOWN: FRONT PANEL

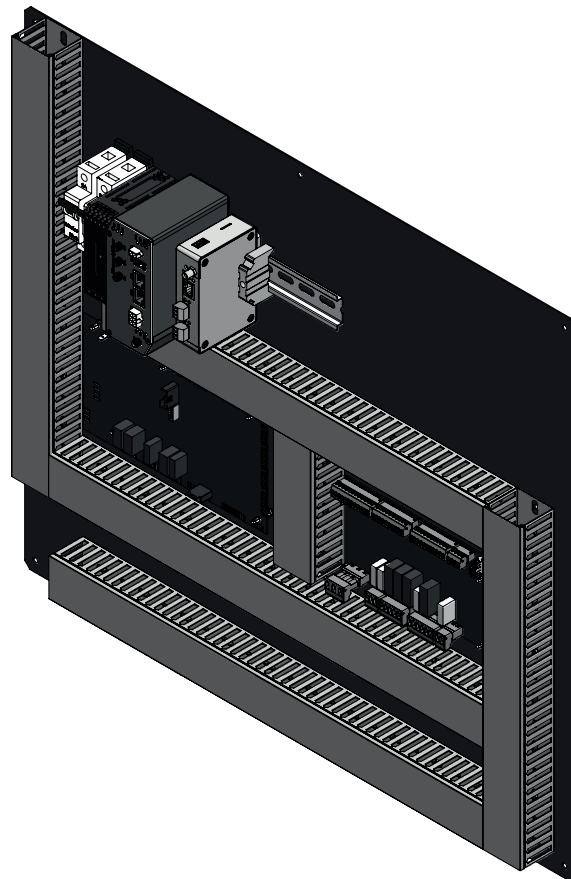
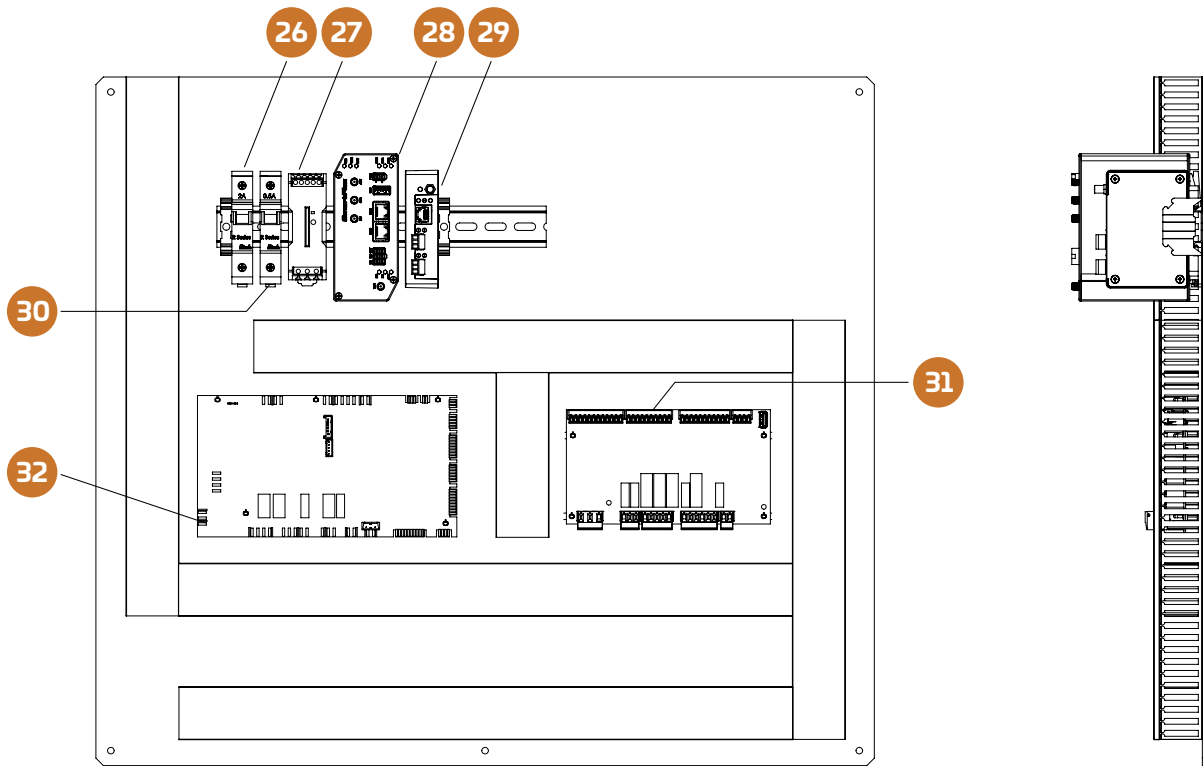

BALLOON ID	PART NUMBER	PART DESCRIPTION	QTY PER ASSEMBLY
1	D133858	ABH XL FRONT DOOR	1
2	D133882	MAG DOOR GASKET	1
3	D133693	SIDE PANEL LATCH	8
4	D133331	PANEL TOP 1000/1500	1
	D133330	PANEL TOP 800	1
5	D133336	PANEL SIDE 1000/1500	2
	D133335	PANEL SIDE 800	2
6	D152597	MIXER AIR/GAS 800NG/LP	1
	D152598	MIXER AIR/GAS 1000NG	1
	D152599	MIXER AIR/GAS 1000LP	1
	D152600	MIXER AIR/GAS 1500NG	1
	D152601	MIXER AIR/GAS 1500LP	1
7	D161676	O-RING RD 110MM X 3.5MM EPDM 70A DURO	1
8	D195574	GAS VALVE	1
9	D133642	GASKET SQ 75MM EPDM 60 W/ 48MM HOLE	1
10	D104962	TRANSDUCER PRESS 1/4 MNPT +/-1 PSI	1
11	D108302	SWITCH RKR ON/OFF 20A 250V DPST	1
12	D113636	SWITCH DIF PRESS M20 CONN CNDS HW79-599	1
13	D195578	GASKET FAN OUT	1
14	D195579	FLOW SWITCH	1
15	D134974	FAN BLOWER	1
16	D104920	THERMISTOR 1/8 NPT X 25 MM 10 KOHM NEGATIVE TEMP COEFFICIENT DUPLEX	1
17	D104919	THERMISTOR 1/8 NPT X 25 MM 10 KOHM NEGATIVE TEMP COEFFICIENT	1
18	D104921	THERMISTOR 1/4 MBSPP X 55 MM 10 KOHM NEGATIVE TEMP COEFFICIENT	1
19	D104963	TRANSDUCER PRESS 1/4 MNPT 0-1/2 PSI	1
20	D106936	SWITCH TEMP LIMIT BURNER DOOR	1
21	D195579	FLOW SWITCH	1
22	D149110	RELAY 120/240V 50/60HZ	4 to 6
23	D149109	IGNITION TRANSFORMER	1
24	D111813	RELAY 120VAC 8A	4 to 6
25	D111813	LOW WATER CUTOFF	1 - optional
26	D106485	BREAKER 2A 1POLE	1
27	D124768	POWER SUPPLY 12VDC 30W 2.5A	1
28	D111152	ROUTER CELLULAR 4G	1
29	D115059	PROTONODE	1
30	D108624	BREAKER .5A 1POLE	1
31	D169173	CASCADE CONTROL BOARD	1
32	D169176	BOILER CONTROL BOARD	1

## PART 11. WARRANTY INFORMATION

### A. WARRANTY CONTACT INFORMATION

Armstrong International warrants each appliance to be free from defects in material and workmanship according to terms, conditions and time periods. *Unless otherwise noted, these warranties commence on the date of installation. If required periodic maintenance is not performed, warranty coverage may be voided.*

Warranty information can be found on our website [www.armstronginternational.com](http://www.armstronginternational.com).

If you have any questions or comments, please contact us at **800.968.5530**. If you need emergency technical support after hours, we are available 24 hours a day, 7 days a week by calling this number.



Please keep the following information on hand when calling about warranty information:

Model: \_\_\_\_\_ Serial #: \_\_\_\_\_

Installer Name: \_\_\_\_\_ Phone #: \_\_\_\_\_ Install Date: \_\_\_\_\_