

APPROVAL

BY: _____ DATE: _____

- APPROVED, PROCEED WITH FABRICATION
- APPROVED AS NOTED, PROCEED WITH FABRICATION IN ACCORDANCE WITH COMMENTS
- DISAPPROVED, DO NOT FABRICATE

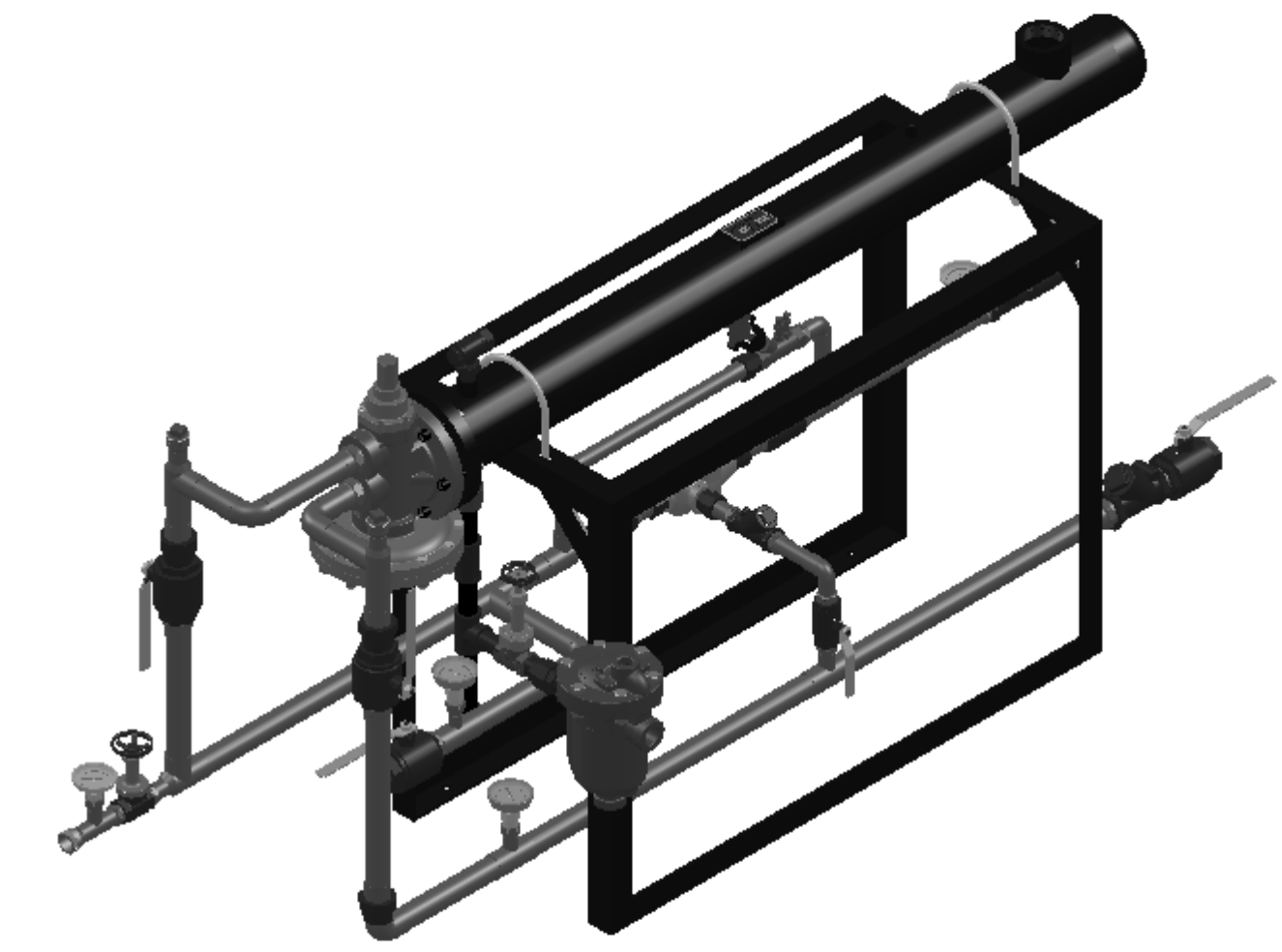

FLO-RITE-TEMP STEAM/WATER HEAT EXCHANGER SINGLE WALL

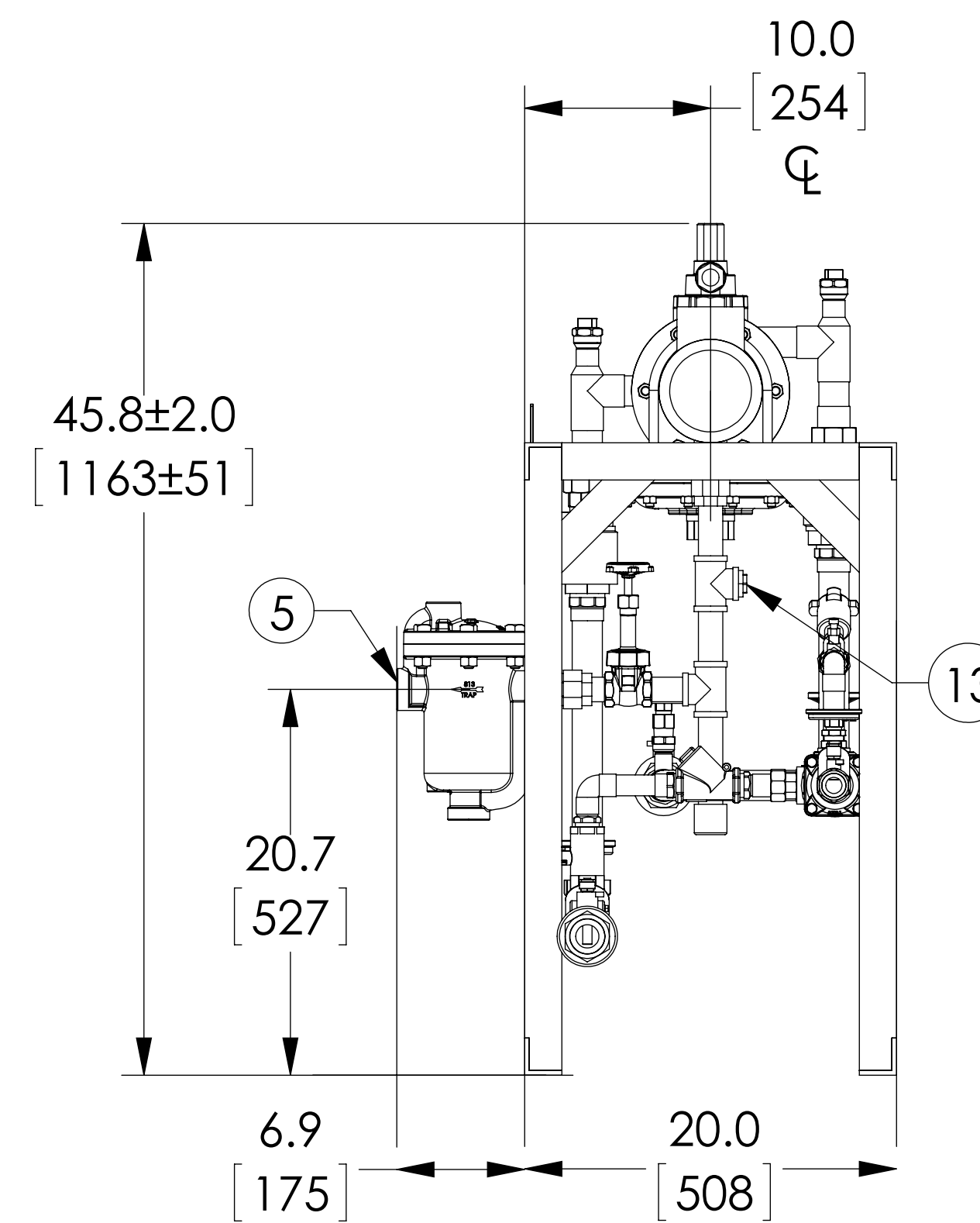
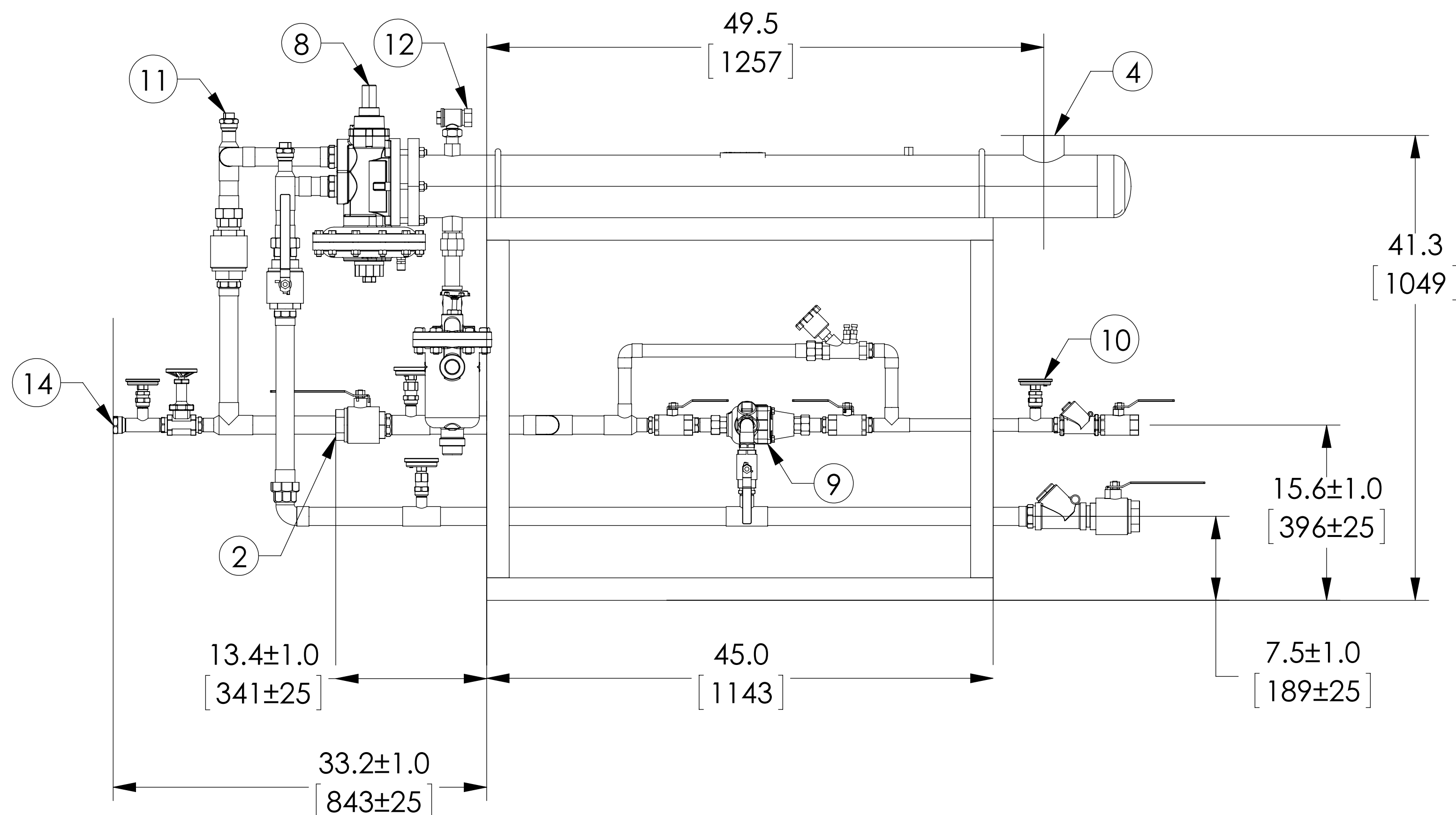
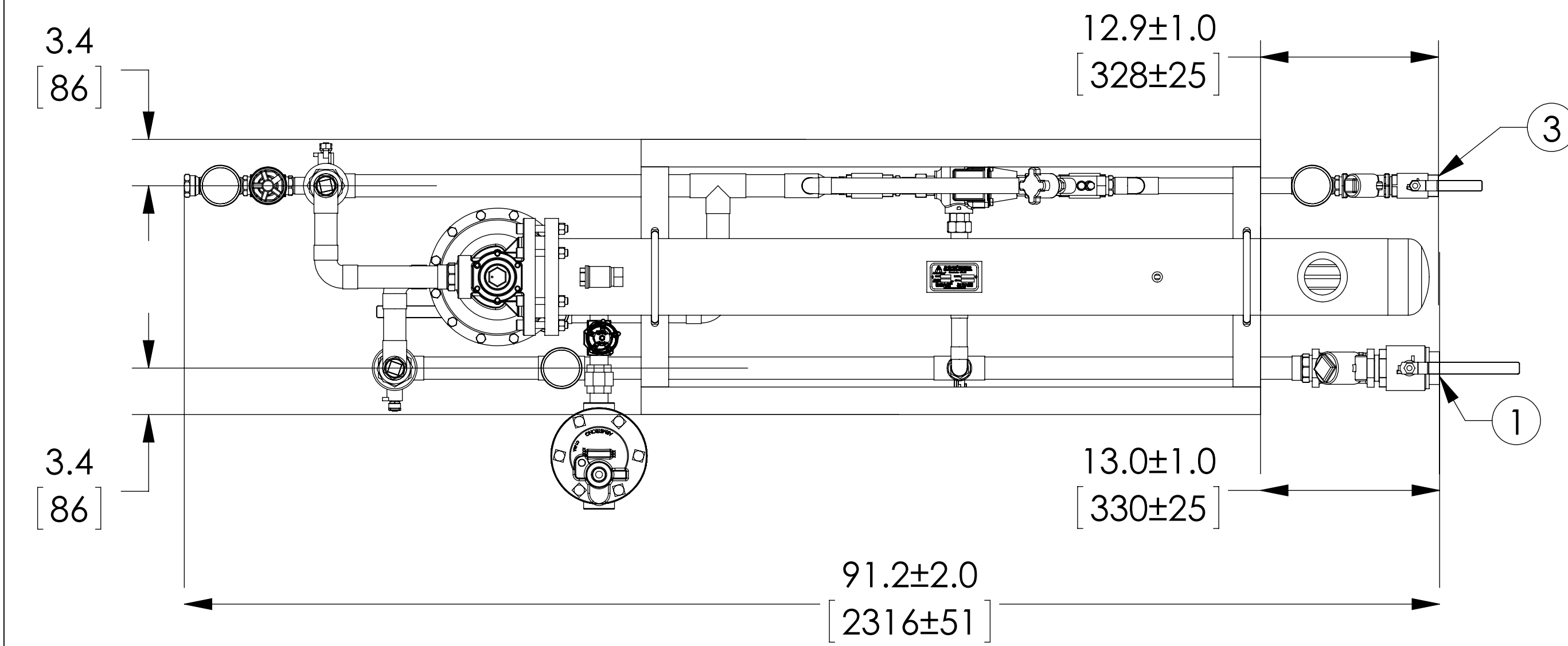

PROJECT NAME :

TAG :

ITEM	DESCRIPTION	CONNECTION
1	COLD WATER INLET	1-1/2" NPT
2	HOT WATER OUTLET	1-1/2" NPT
3	RECIRC WATER INLET	1" NPT
4	STEAM INLET	2-1/2" NPT
5	CONDENSATE OUTLET	1" NPT 813 IB
6	N/A	N/A
7	N/A	N/A
8	CONTROL VALVE LT	1-1/2" NPT
9	FLUID POWER VALVE	1" NPT
10	THERMOMETER (4)	
11	CIP CONNECTION (2)	1" NPT
12	AIR VENT	3/4" NPT
13	VACUUM BREAKER	1/2" NPT
14	BYPASS TO DRAIN	1" NPT
ITEM	MATERIAL	
PIPING	COPPER TYPE "L"	
EXCHANGER SHELL MATL.	CARBON STEEL	
EXCHANGER TUBE MATL.	LEAD FREE BRASS	
	SET POINT	100°F

NOTE(S):

1. ARMSTRONG PART NUMBER : D611244
2. ALL DIMENSIONS +/- 0.5[13] UNLESS OTHERWISE SHOWN.
3. COMPLETE ASSEMBLY LEAD FREE COMPLIANT - THE WETTED SURFACE OF THIS PRODUCT CONTACTED BY CONSUMABLE WATER CONTAINS LESS THAN ONE QUARTER OF ONE PERCENT (0.25%) OF LEAD BY WEIGHT.
4. N/A.

DO NOT SCALE DRAWING TOLERANCES UNLESS OTHERWISE SPECIFIED	
DIMENSIONING ENGLISH [mm]	
FRACTIONAL ± 1/64	
ANGULAR: ± 2	
DECIMAL	IN. MM
.XXXX ± .0005	----
.XXX ± .005	.010
.XX ± .015	.10
.X	.3

NAME	DATE
DRAWN CFG	7/17/2014
RELEASED SALES	

ARMSTRONG INTERNATIONAL Copyright © 2010 ARMSTRONG INTERNATIONAL, INC.	
FRT535R100F 1-1/2 NPT 1-1/2 NPT 1 NPT CPR	
CONFIG# (C-147837)	
MATERIAL	SHEET 1 OF 1
REV A	DWG. SALES