

**NOTES:**

- TANK MATERIAL: STAINLESS STEEL
- ALL DIMENSIONS ARE ±0.25"
- DRAWING NOT FOR CONSTRUCTION
- CONSULT FACTORY AT TIME OF ORDER FOR CURRENT PRINT

**CONTROL PANEL OPTIONS ALSO AVAILABLE (NOT SHOWN):**

- NEMA 4 OR NEMA 4X OR NEMA 3R CONSTRUCTION
- ELECTRIC ALTERNATOR
- POWER ON LIGHT
- PUMP TEST BUTTON
- PUMP RUN TIME METER
- EXTRA DRY CONTACTS
- UL/CUL LABELED PANEL
- HIGH LEVEL ALARM HORN & LIGHT W/SILENCE SWITCH
- LEAD-AUTO-LAG SELECTOR SWITCH

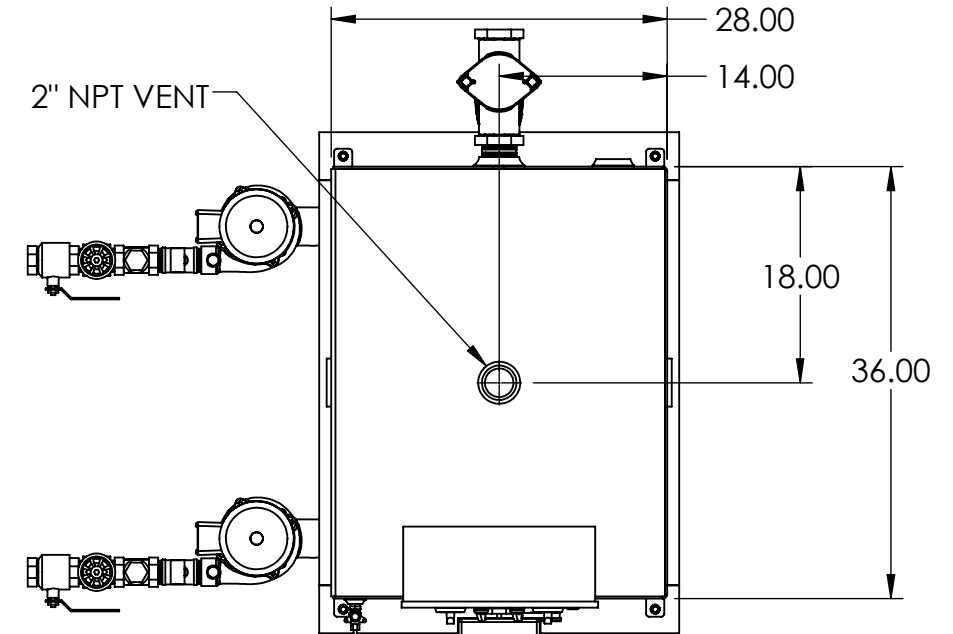
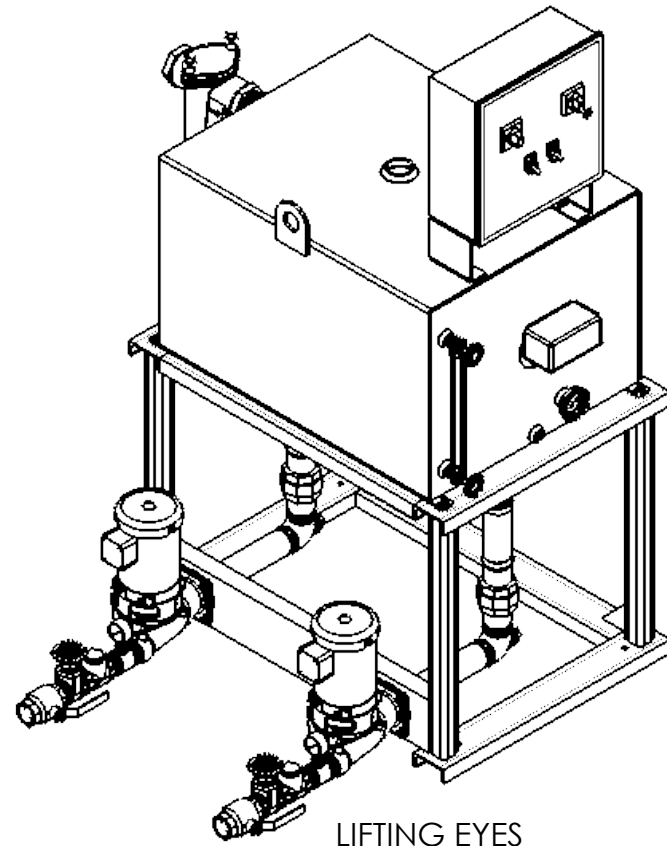

2" NPT VENT  
NEMA 12 CONTROL PANEL (OPTIONAL)

FLOAT SWITCH OR ALTERNATOR

THERMOMETER (OPTIONAL)

GAUGE GLASS (OPTIONAL)

ISOLATION VALVE

1-1/2" NPT PUMP DISCHARGE

1/2" MOUNTING HOLES (QTY = 4)

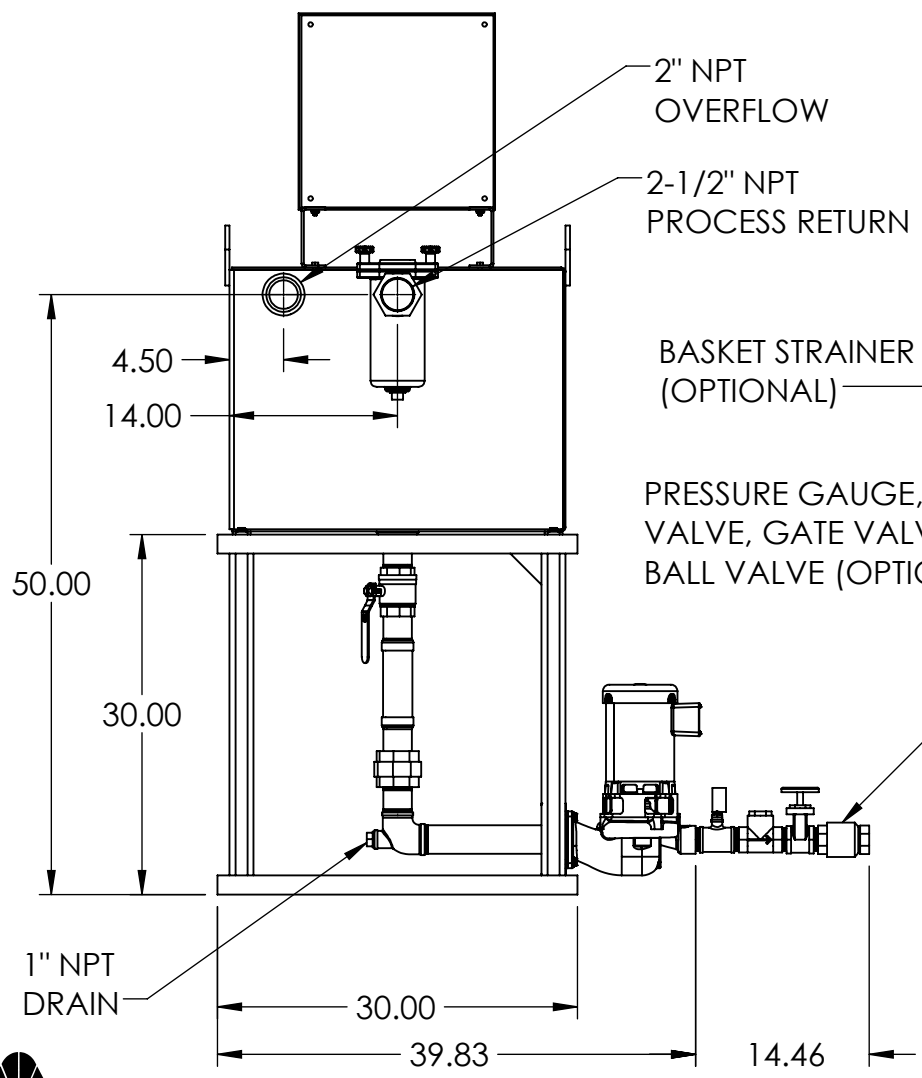
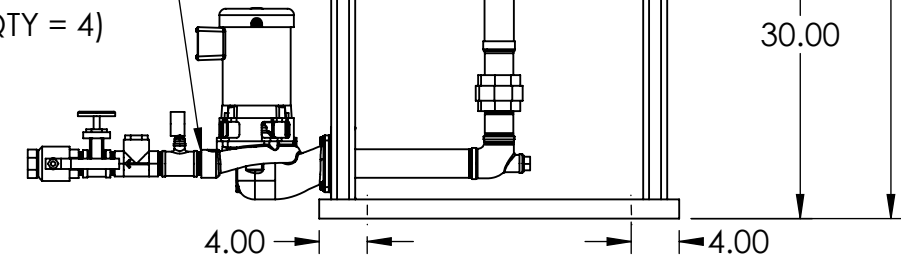

2" NPT OVERFLOW

2-1/2" NPT PROCESS RETURN

BASKET STRAINER (OPTIONAL)

PRESSURE GAUGE, CHECK VALVE, GATE VALVE AND BALL VALVE (OPTIONAL)

LIFTING EYES (OPTIONAL)

1" NPT DRAIN

REV	DESCRIPTION	ECN	NAME	DATE
A	INITIAL DESIGN		GJM	11/1/2017

PART NO:	684.48095.10	NAME	GJM	DATE	11/1/2017
FABRICATION TOLERANCES UNLESS OTHERWISE SPECIFIED: DIMENSIONS ARE IN INCHES	DRAWN	CHECKED	ENG APPR.	THIRD ANGLE PROJECTION	
TOLERANCES: ANGULAR DIMENSIONS ±1° FRACTIONS ±1/32	PRODUCT FAMILY		TITLE		
TWO PLACE DECIMAL ±0.06 THREE PLACE DECIMAL ±0.030	HTSP Boiler and Condensate		95 GALLON DUPLEX 4800 SERIES, ELEVATED "K" CONDENSATE PUMP		
SHEET: 1 OF 1	WEIGHT	DRAWING MAY NOT BE PRINTED TO SCALE.	DWG NO.	REV	
	876.60	SCALE: 1:16	684.48095.10	A	



armstronginternational.com