

NOTES:

- TANK MATERIAL: STAINLESS STEEL
- ALL DIMENSIONS ARE $\pm 0.25"$
- DRAWING NOT FOR CONSTRUCTION
- CONSULT FACTORY AT TIME OF ORDER FOR CURRENT PRINT

CONTROL PANEL OPTIONS ALSO AVAILABLE (NOT SHOWN):

- NEMA 4 OR NEMA 4X OR NEMA 3R CONSTRUCTION
- ELECTRIC ALTERNATOR
- POWER ON LIGHT
- PUMP TEST BUTTON
- PUMP RUN TIME METER
- EXTRA DRY CONTACTS
- UL/CUL LABELED PANEL
- HIGH LEVEL ALARM HORN & LIGHT W/SILENCE SWITCH
- LEAD-AUTO-LAG SELECTOR SWITCH

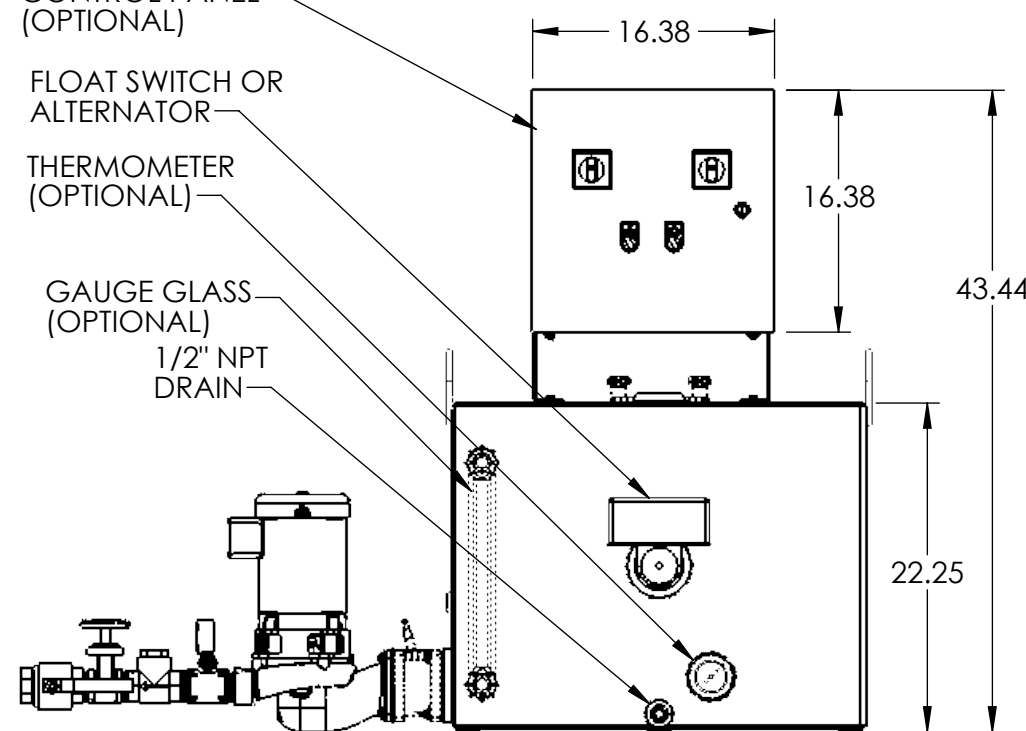
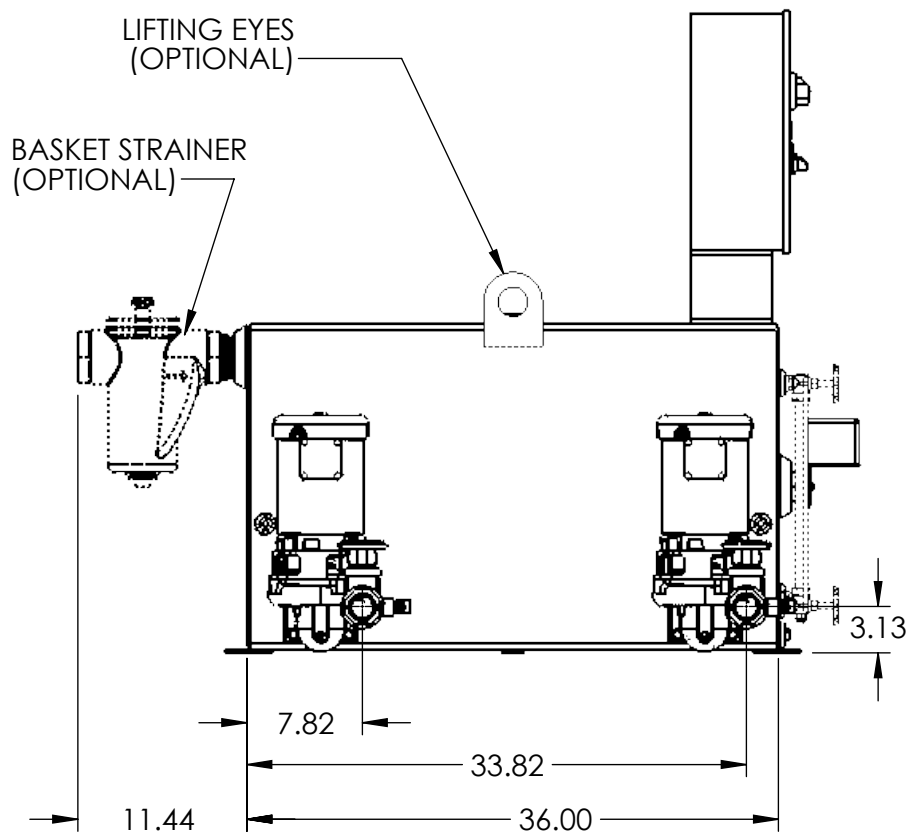
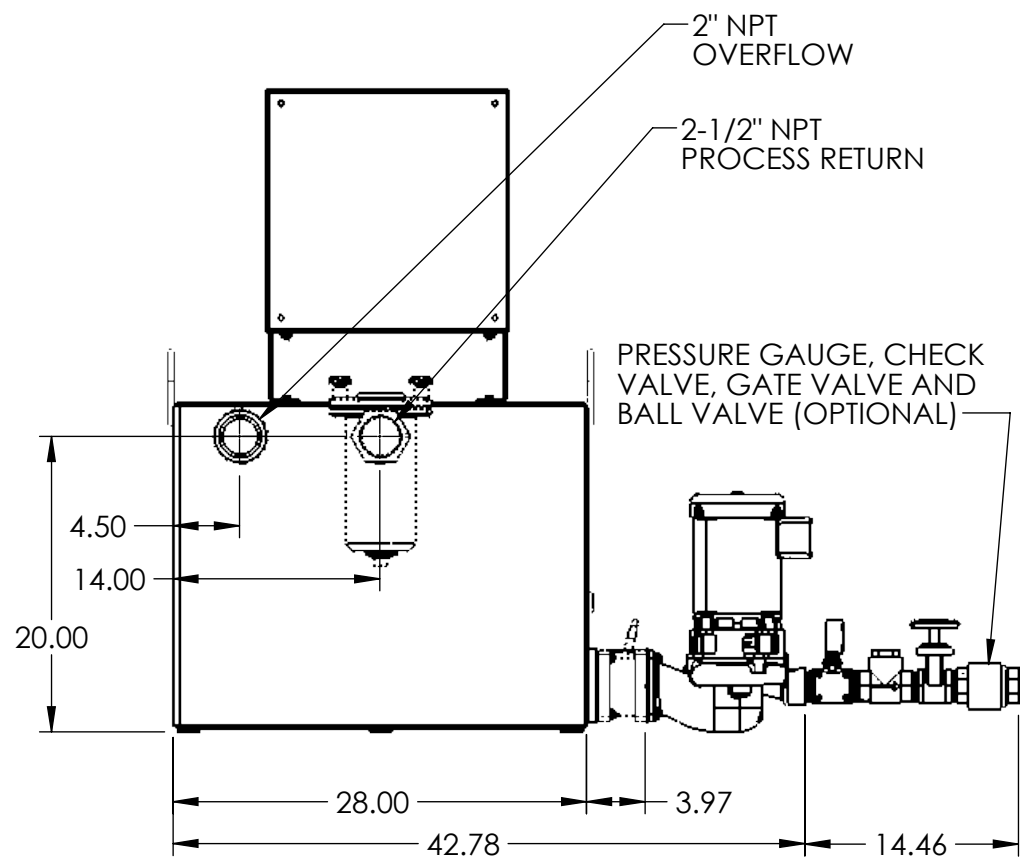
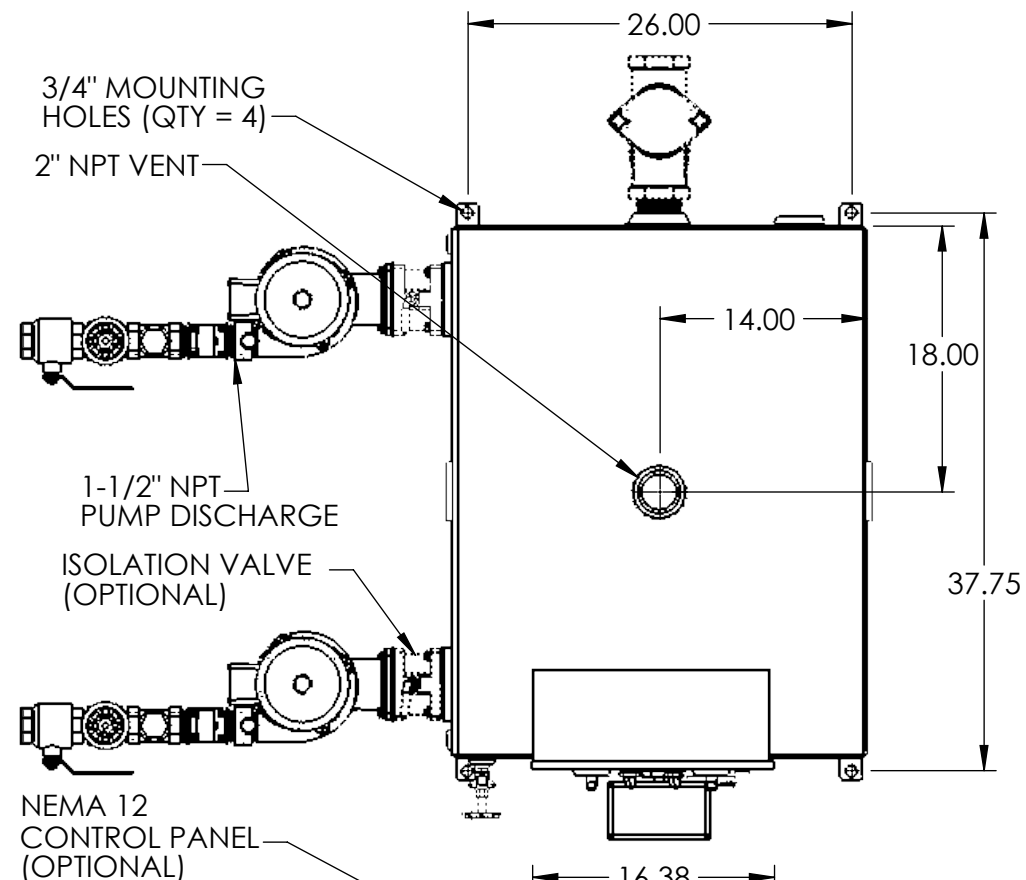
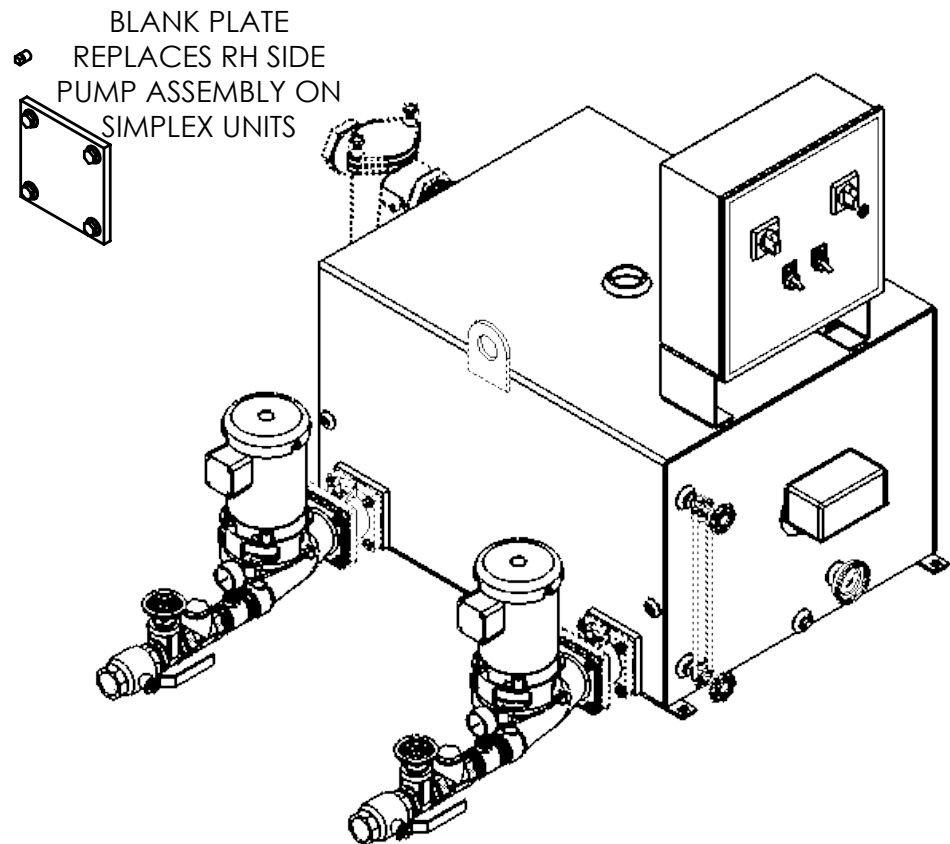

REV	DESCRIPTION	ECN	NAME	DATE
A	Initial Design		GJM	10/31/2017
PART NO: 684.48095.00		NAME	DATE	
DRAWN		GJM	10/31/2017	
CHECKED				
ENG APPR.				
PRODUCT FAMILY		HTSP Boiler and Condensate		
PRODUCT CATEGORY				
FABRICATION TOLERANCES UNLESS OTHERWISE SPECIFIED: DIMENSIONS ARE IN INCHES		THIRD ANGLE PROJECTION		
TOLERANCES: ANGULAR DIMENSIONS $\pm 1^\circ$ FRACTIONS $\pm 1/32$		TITLE		
TWO PLACE DECIMAL ± 0.06 THREE PLACE DECIMAL ± 0.030		95 GALLON SIMPLEX/DUPLEX 4800 SERIES "K" CONDENSATE PUMP		
SHEET: 1 OF 1		WEIGHT	DRAWING MAY NOT BE PRINTED TO SCALE.	DWG NO.
		459.94	SCALE: 1:13	684.48095.00
				REV A