

NOTES:

- TANK MATERIAL: STAINLESS STEEL
- ALL DIMENSIONS ARE $\pm 0.25"$
- DRAWING NOT FOR CONSTRUCTION
- CONSULT FACTORY AT TIME OF ORDER FOR CURRENT PRINT

CONTROL PANEL OPTIONS ALSO AVAILABLE (NOT SHOWN):

- NEMA 4 OR NEMA 4X OR NEMA 3R CONSTRUCTION
- ELECTRIC ALTERNATOR
- POWER ON LIGHT
- PUMP TEST BUTTON
- PUMP RUN TIME METER
- EXTRA DRY CONTACTS
- UL/CUL LABELED PANEL
- HIGH LEVEL ALARM HORN & LIGHT W/SILENCE SWITCH
- LEAD-AUTO-LAG SELECTOR SWITCH

D

C

B

A

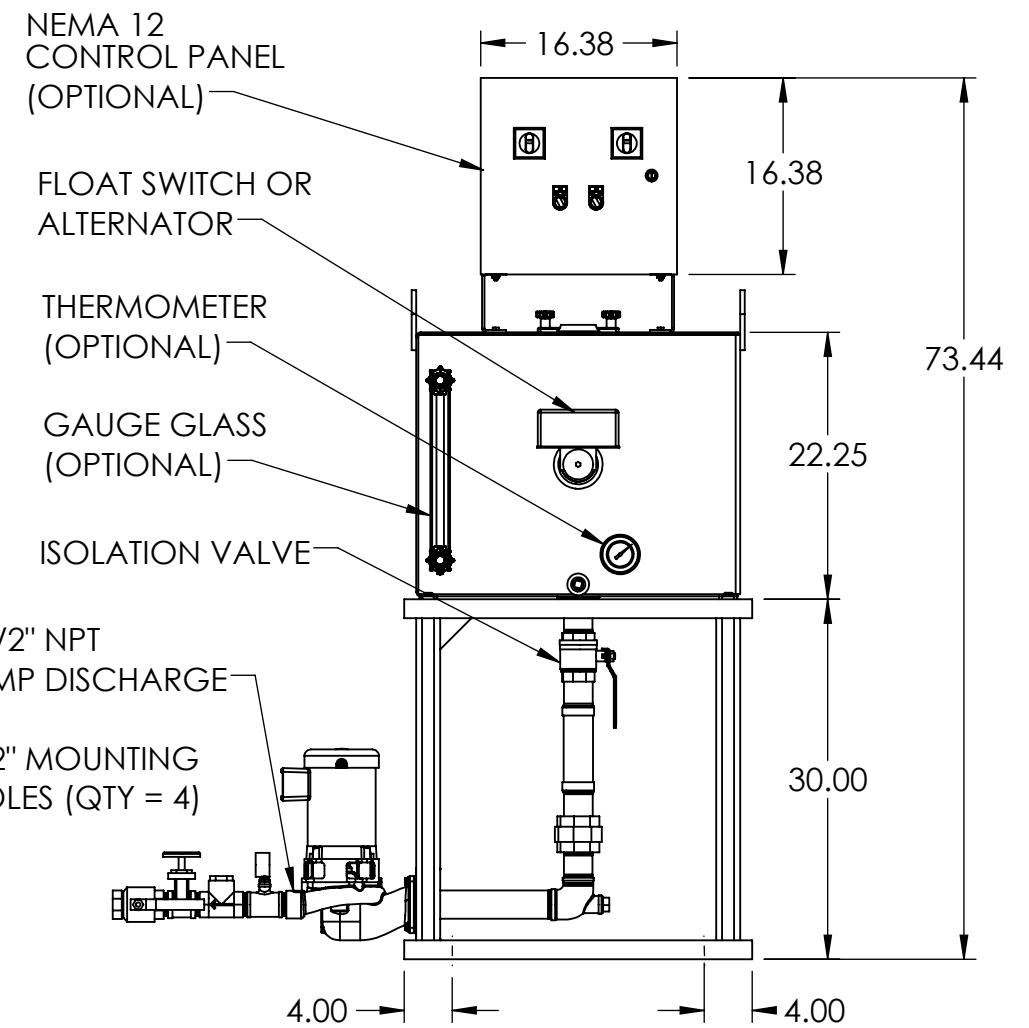
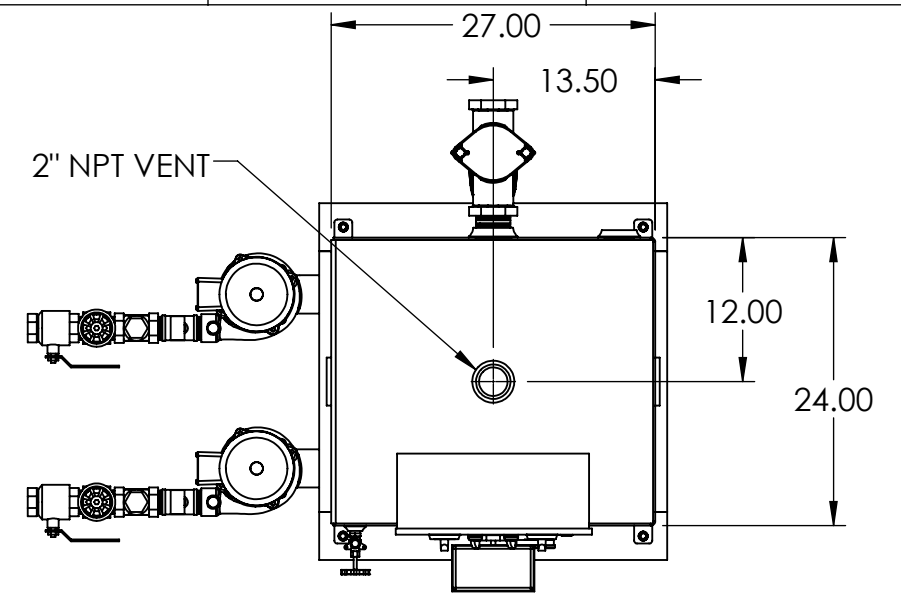
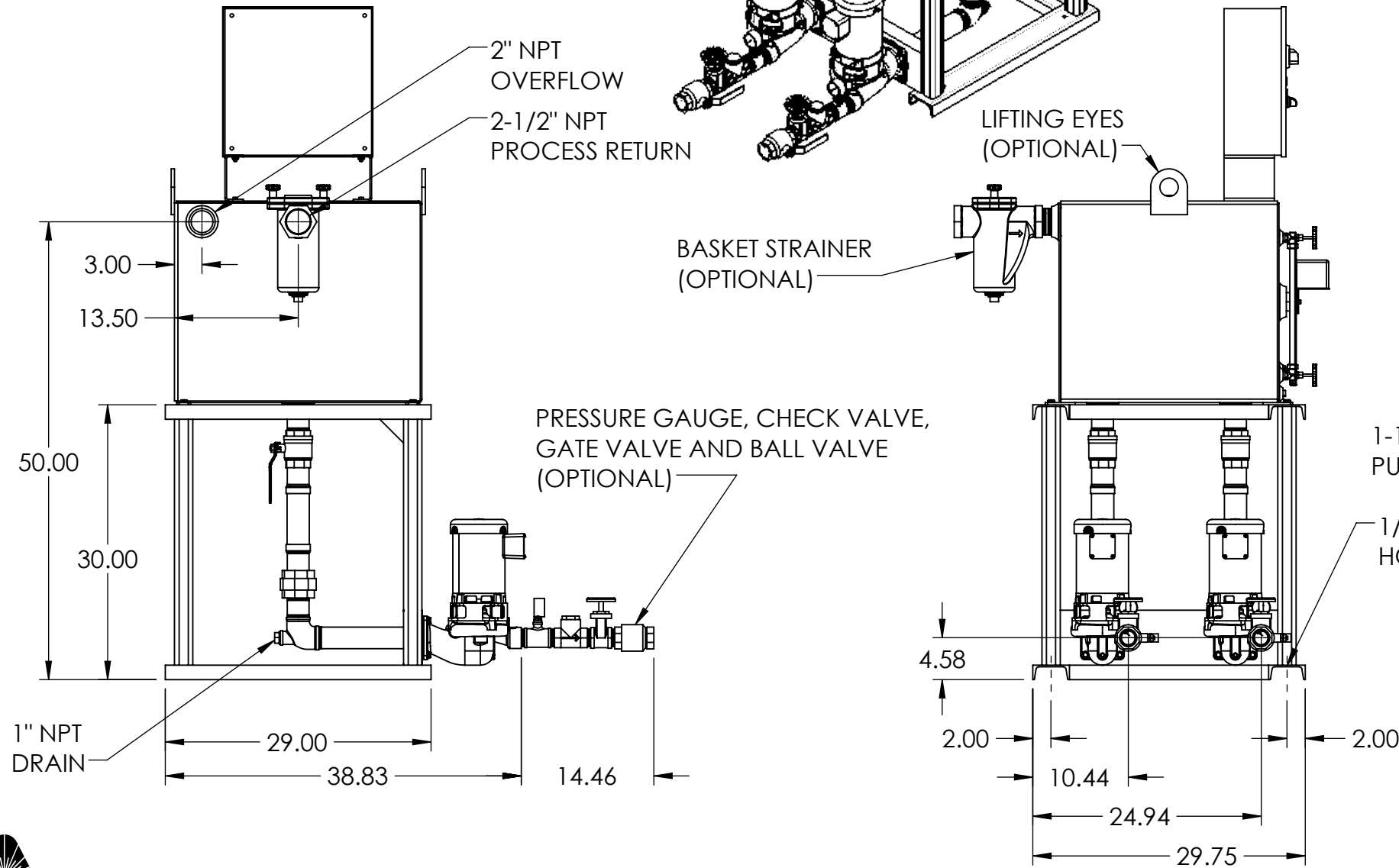
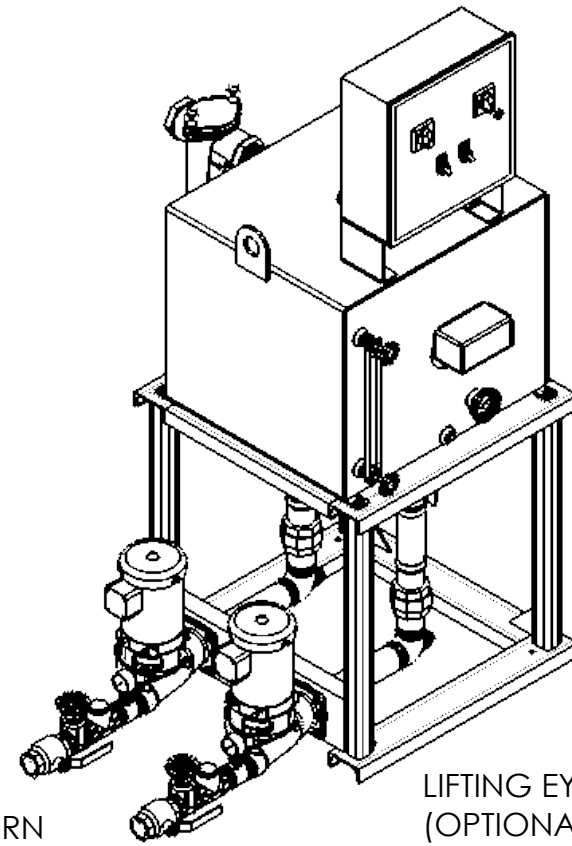

REV	DESCRIPTION	ECN	NAME	DATE
A	INITIAL DESIGN		GJM	11/1/2017

PART NO: 684.48060.10	NAME: GJM	DATE: 11/1/2017	 THIRD ANGLE PROJECTION TITLE 60 GALLON DUPLEX 4800 SERIES, ELEVATED "K" CONDENSATE PUMP	
FABRICATION TOLERANCES UNLESS OTHERWISE SPECIFIED: DIMENSIONS ARE IN INCHES	DRAWN			
TOLERANCES: ANGULAR DIMENSIONS $\pm 1^\circ$ FRACTIONS $\pm 1/32$	CHECKED			
TWO PLACE DECIMAL ± 0.06 THREE PLACE DECIMAL ± 0.030	ENG APPR.			
	PRODUCT FAMILY HTSP Boiler and Condensate PRODUCT CATEGORY 4600			
SHEET: 1 OF 1	WEIGHT: 782.66	DRAWING MAY NOT BE PRINTED TO SCALE. SCALE: 1:16	DWG NO. 684.48060.10	REV A

