

NOTES:

- TANK MATERIAL: STAINLESS STEEL
- ALL DIMENSIONS ARE ±0.25"
- DRAWING NOT FOR CONSTRUCTION
- CONSULT FACTORY AT TIME OF ORDER FOR CURRENT PRINT

CONTROL PANEL OPTIONS ALSO AVAILABLE (NOT SHOWN):

- NEMA 4 OR NEMA 4X OR NEMA 3R CONSTRUCTION
- ELECTRIC ALTERNATOR
- POWER ON LIGHT
- PUMP TEST BUTTON
- PUMP RUN TIME METER
- EXTRA DRY CONTACTS
- UL/CUL LABELED PANEL
- HIGH LEVEL ALARM HORN & LIGHT W/SILENCE SWITCH
- LEAD-AUTO-LAG SELECTOR SWITCH

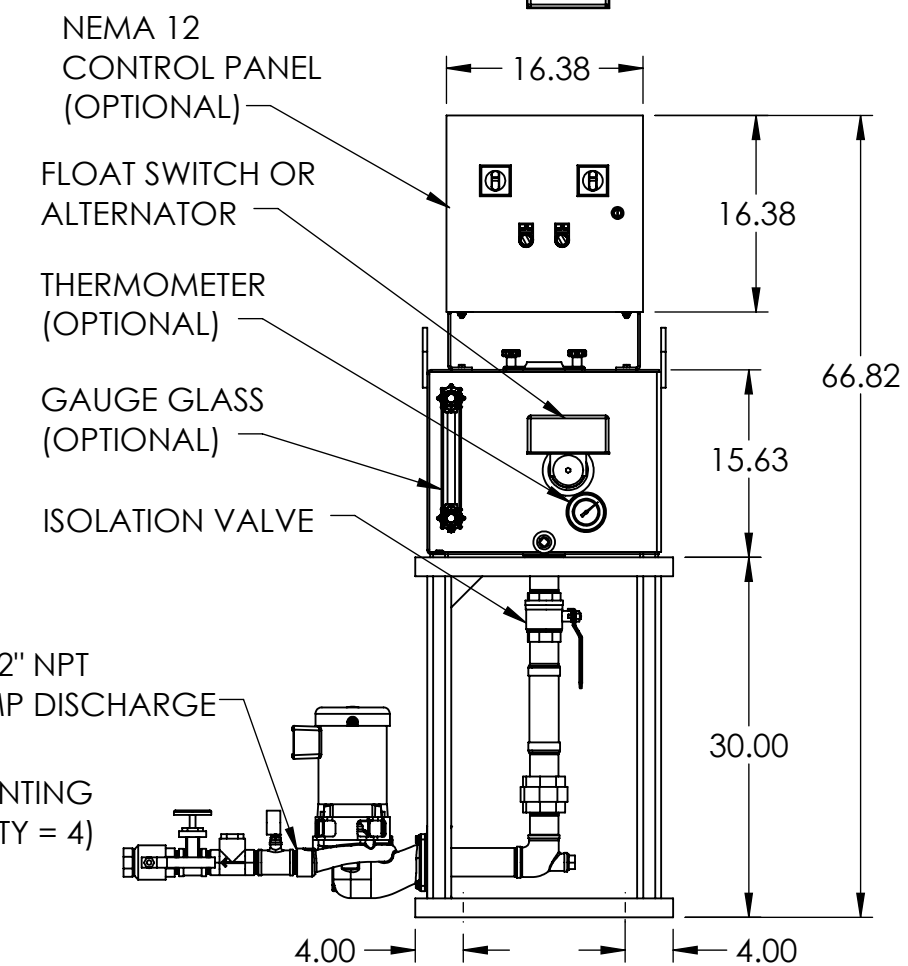
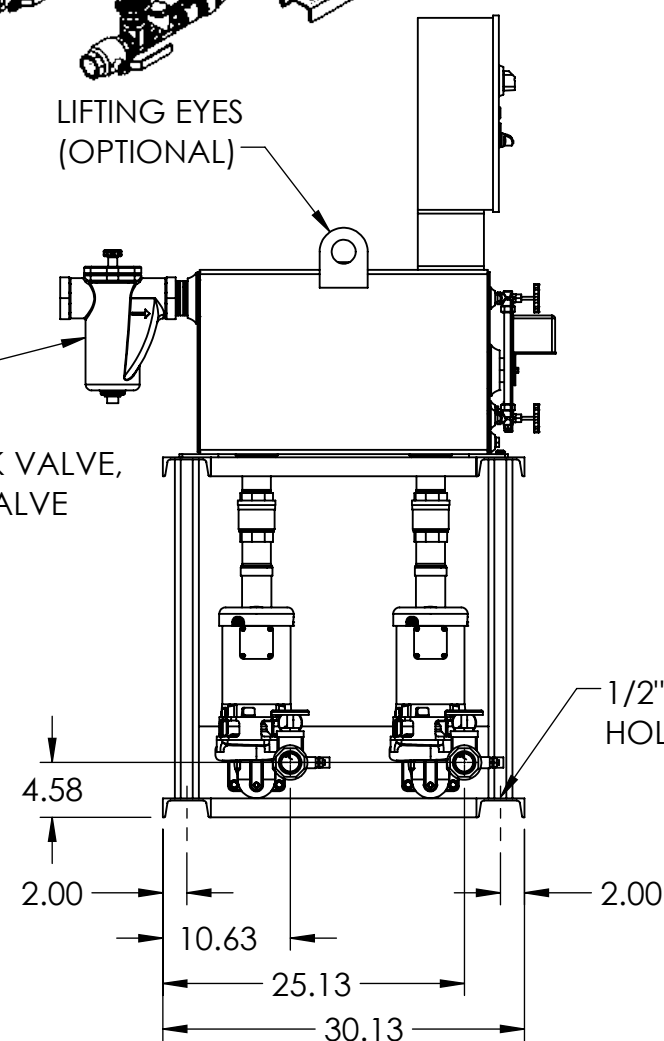
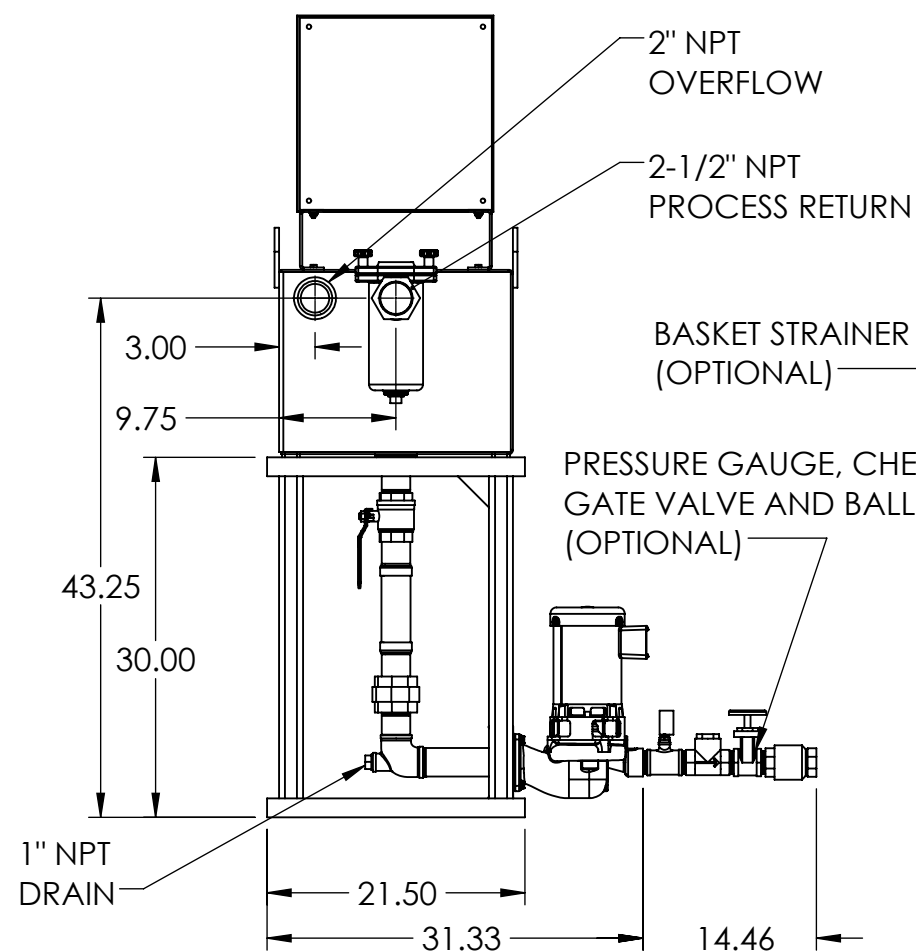
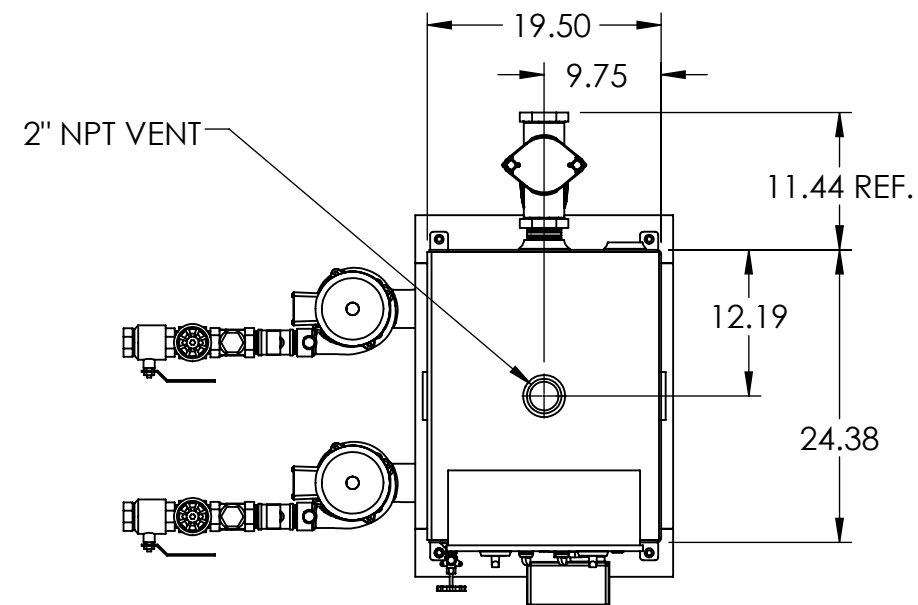
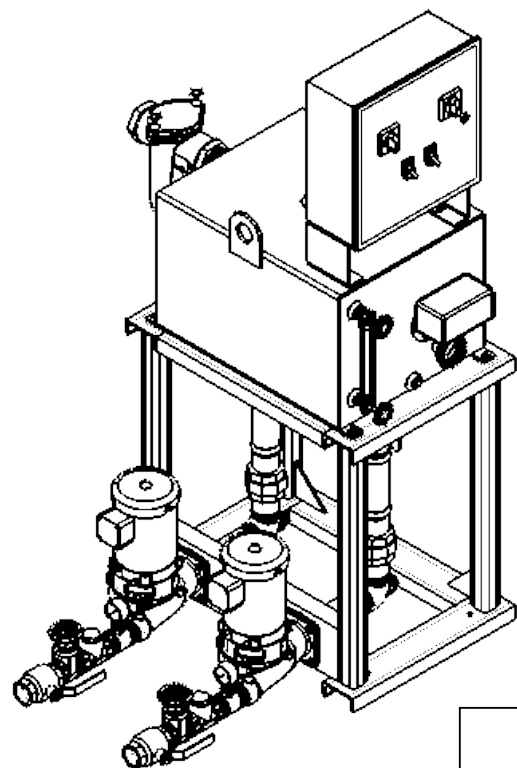

armstronginternational.com

REV	DESCRIPTION	ECN	NAME	DATE
A	INITIAL DESIGN		GJM	11/1/2017
PART NO: 684.48030.10		NAME	DATE	
DRAWN		GJM	11/1/2017	
CHECKED				
ENG APPR.				
PRODUCT FAMILY		HTSP Boiler and Condensate		
PRODUCT CATEGORY		4600		
SHEET: 1 OF 1		WEIGHT	DRAWING MAY NOT BE PRINTED TO SCALE.	DWG NO.
2676.06		SCALE: 1:16	684.48030.10	REV A

THIRD ANGLE PROJECTION
**30 GALLON DUPLEX
 4800 SERIES, ELEVATED
 "K" CONDENSATE PUMP**