

**NOTES:**

- TANK MATERIAL: STAINLESS STEEL
- ALL DIMENSIONS ARE ±0.25"
- DRAWING NOT FOR CONSTRUCTION
- CONSULT FACTORY AT TIME OF ORDER FOR CURRENT PRINT

**CONTROL PANEL OPTIONS ALSO AVAILABLE (NOT SHOWN):**

- NEMA 4 OR NEMA 4X OR NEMA 3R CONSTRUCTION
- POWER ON LIGHT
- PUMP TEST BUTTON
- PUMP RUN TIME METER
- EXTRA DRY CONTACTS
- UL/CUL LABELED PANEL
- HIGH LEVEL ALARM HORN & LIGHT W/SILENCE SWITCH

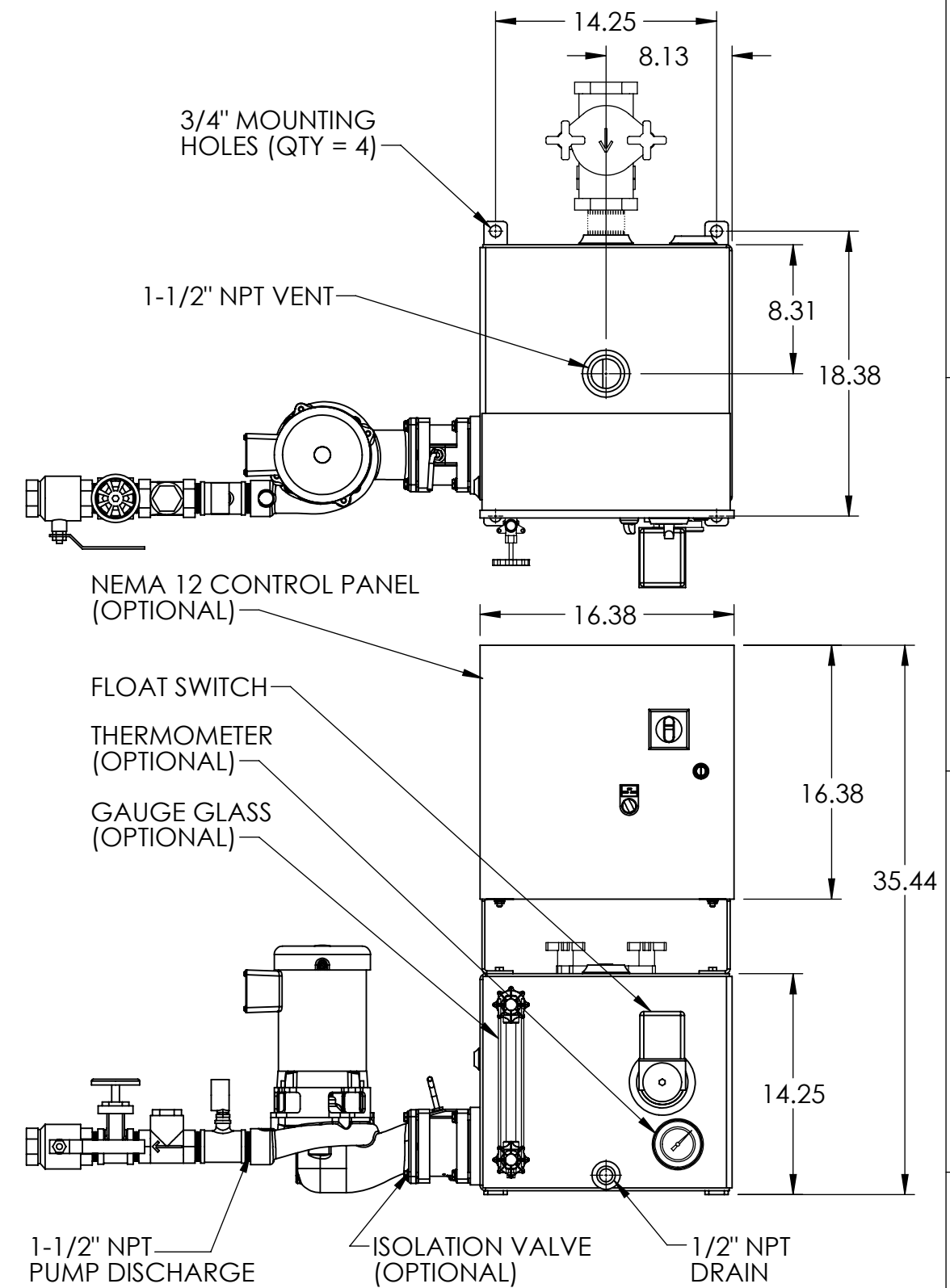
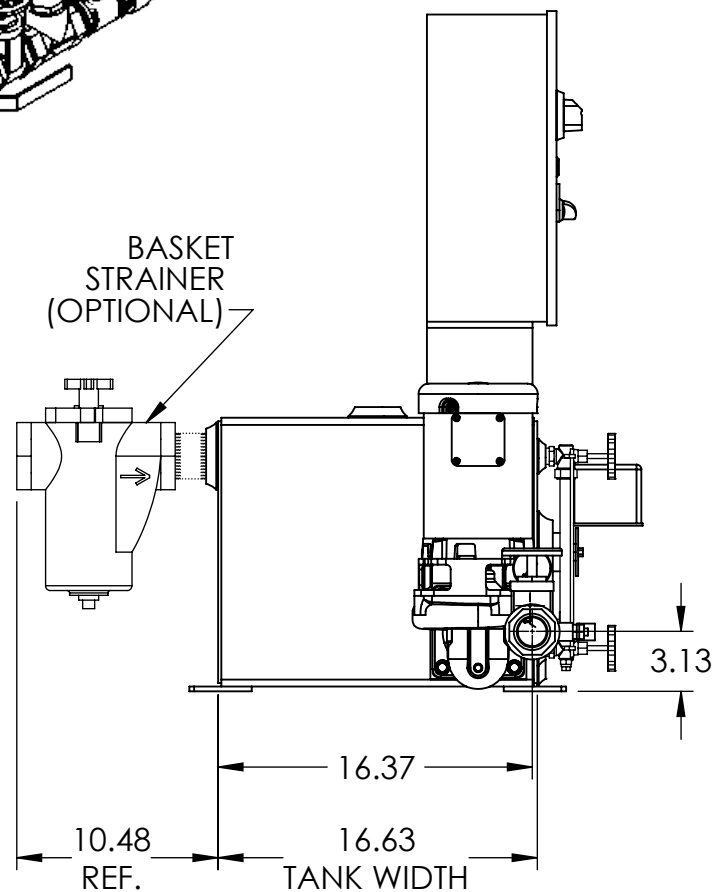
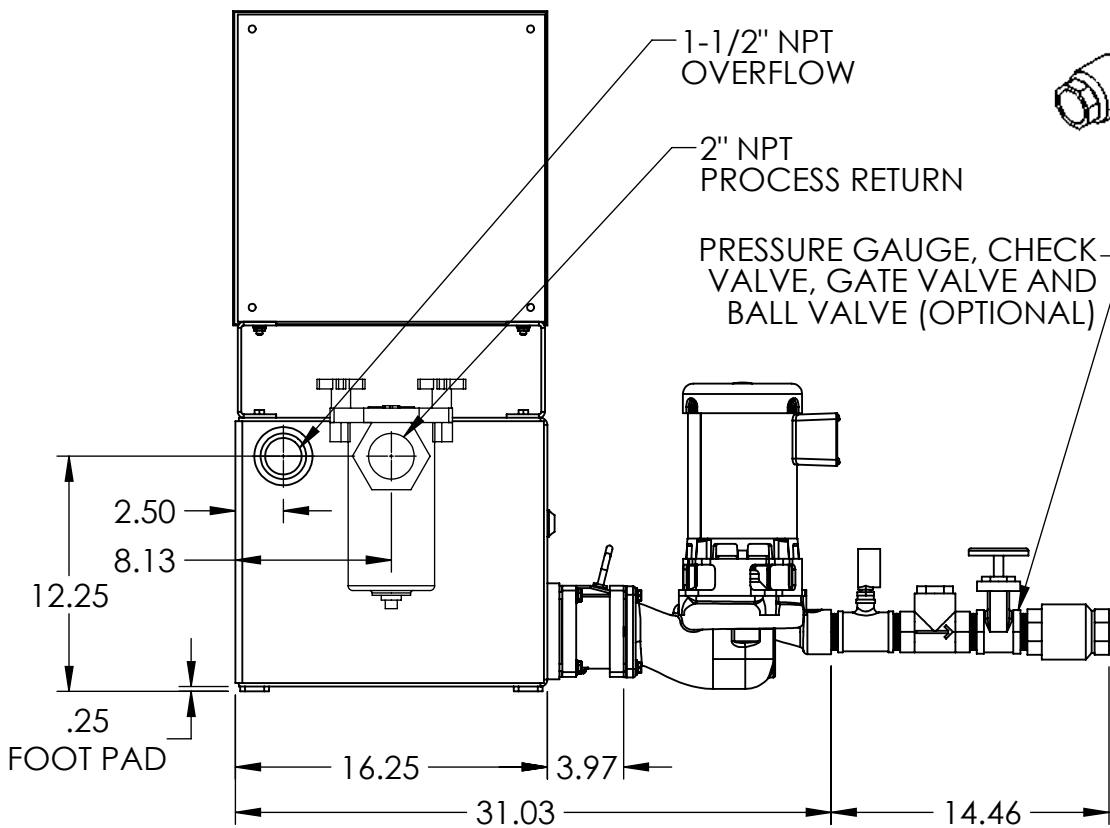
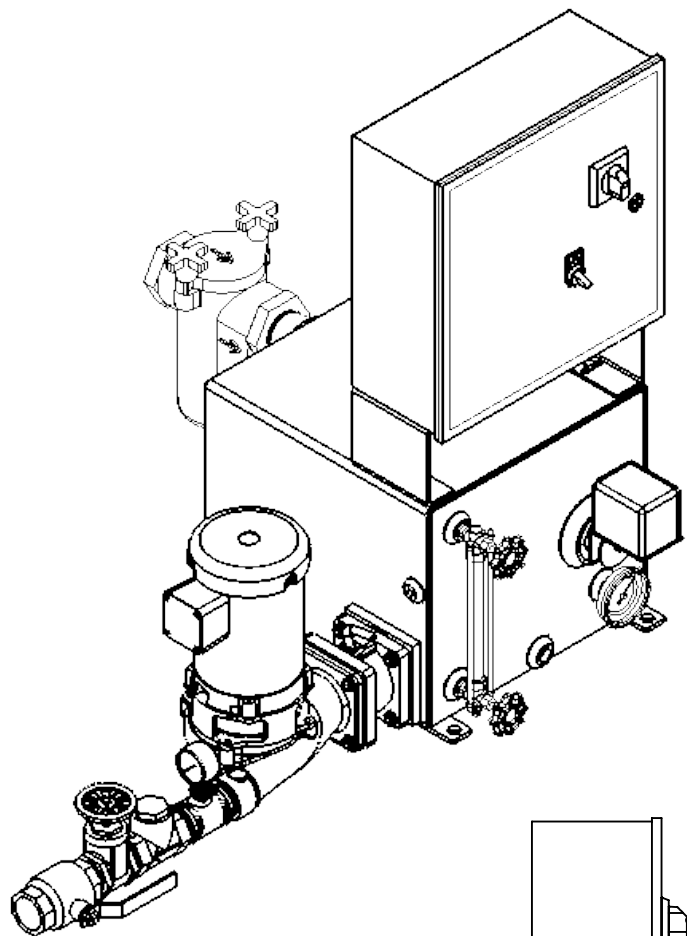

REV	DESCRIPTION	ECN	NAME	DATE
A	INITIAL DESIGN		GJM	10/17/2017

PART NO:	Ref PartNo	NAME	DATE	 THIRD ANGLE PROJECTION TITLE <b>15 GALLON SIMPLEX 4800 SERIES "K" CONDENSATE PUMP</b>
FABRICATION TOLERANCES UNLESS OTHERWISE SPECIFIED: DIMENSIONS ARE IN INCHES	DRAWN	GJM	10/17/2017	
TOLERANCES: ANGULAR DIMENSIONS ±1° FRACTIONS ±1/32	CHECKED			
TWO PLACE DECIMAL ±0.06 THREE PLACE DECIMAL ±0.030	ENG APPR.			
	PRODUCT FAMILY HTSP Boiler and Condensate			
	PRODUCT CATEGORY 4100			
SHEET: 1 OF 1	WEIGHT 1196.51	DRAWING MAY NOT BE PRINTED TO SCALE. SCALE: 1:10		DWG NO. 684.48015.01

