

NOTES:

- TANK MATERIAL: STAINLESS STEEL
- ALL DIMENSIONS ARE ±0.25"
- DRAWING NOT FOR CONSTRUCTION
- CONSULT FACTORY AT TIME OF ORDER FOR CURRENT PRINT

CONTROL PANEL OPTIONS ALSO AVAILABLE (NOT SHOWN):

- NEMA 4 OR NEMA 4X OR NEMA 3R CONSTRUCTION
- ELECTRIC ALTERNATOR
- POWER ON LIGHT
- PUMP TEST BUTTON
- PUMP RUN TIME METER
- EXTRA DRY CONTACTS
- UL/CUL LABELED PANEL
- HIGH LEVEL ALARM HORN & LIGHT W/SILENCE SWITCH
- LEAD-AUTO-LAG SELECTOR SWITCH

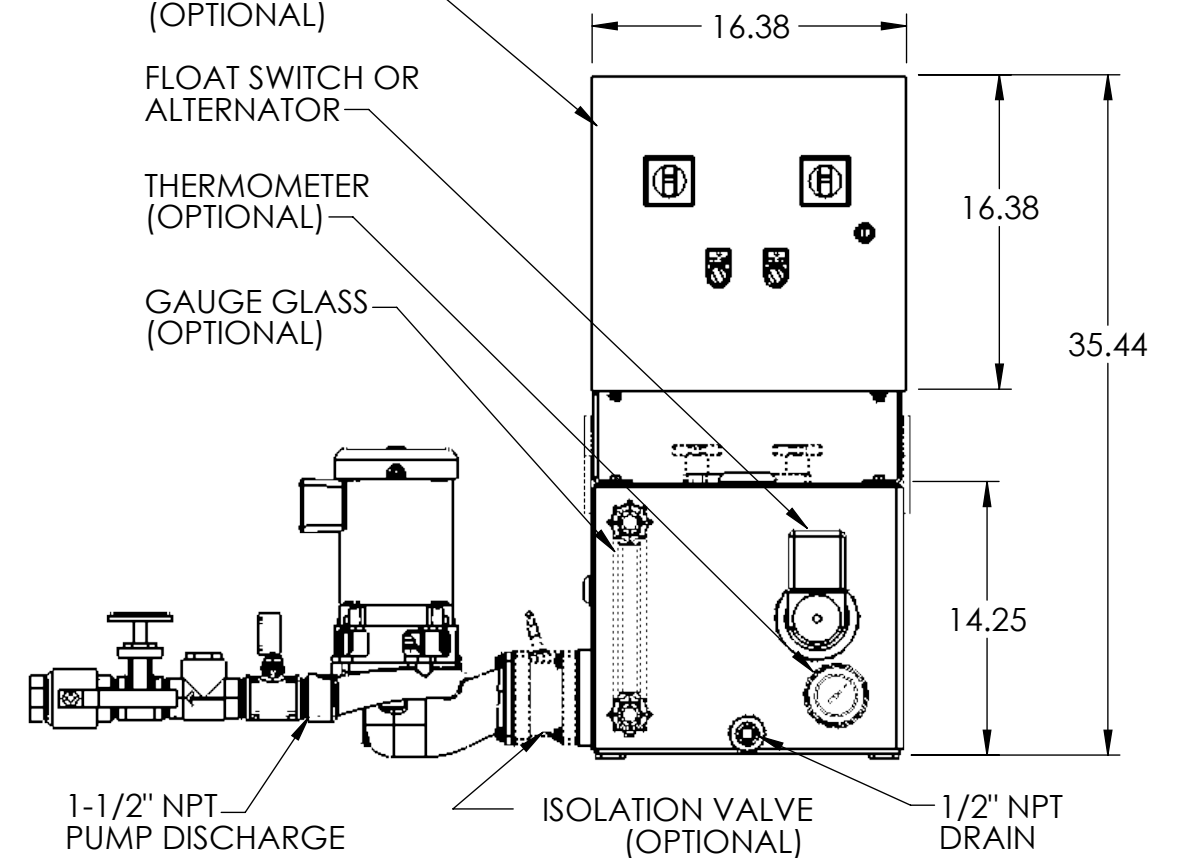
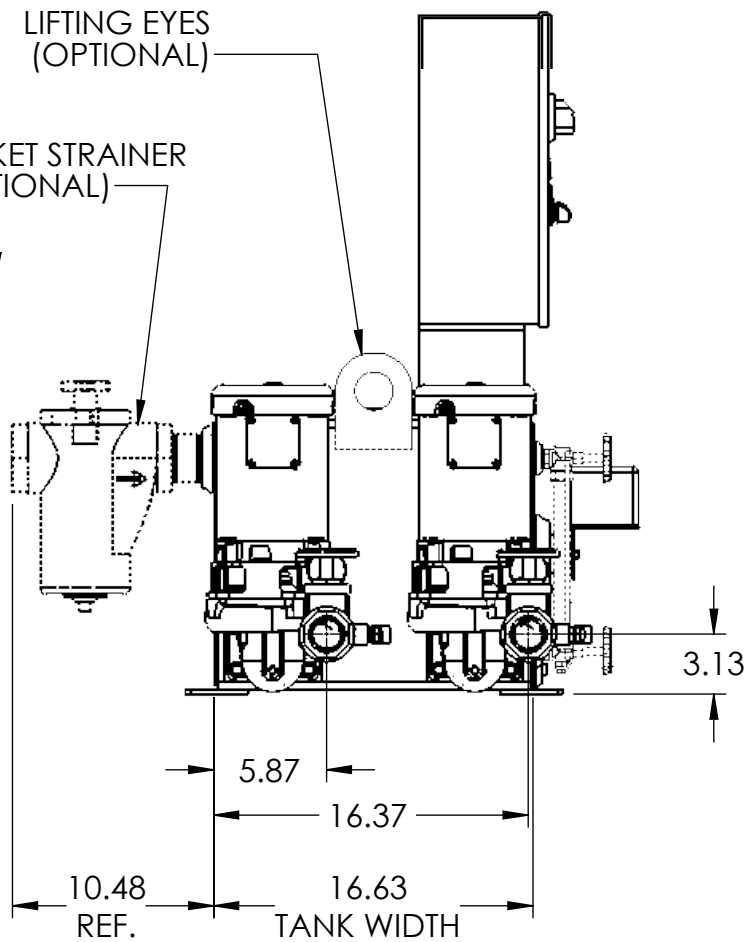
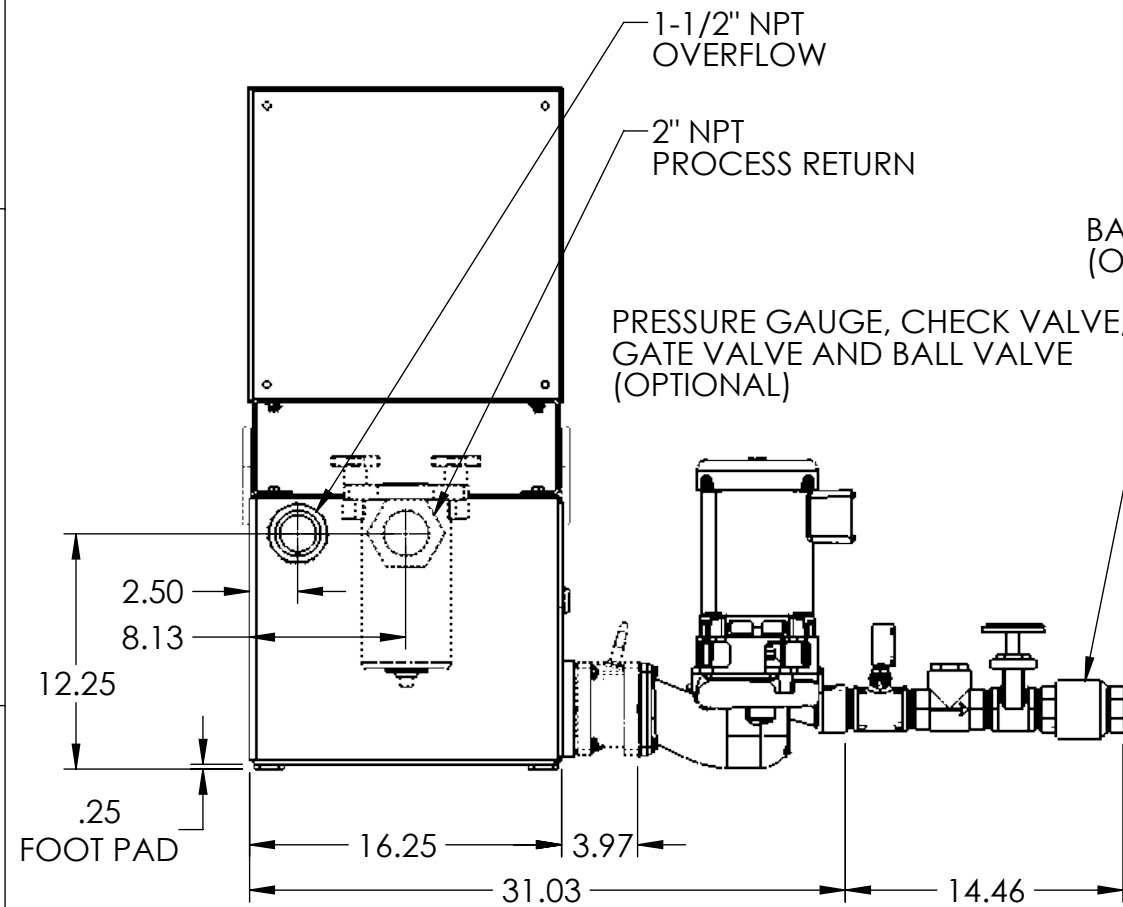
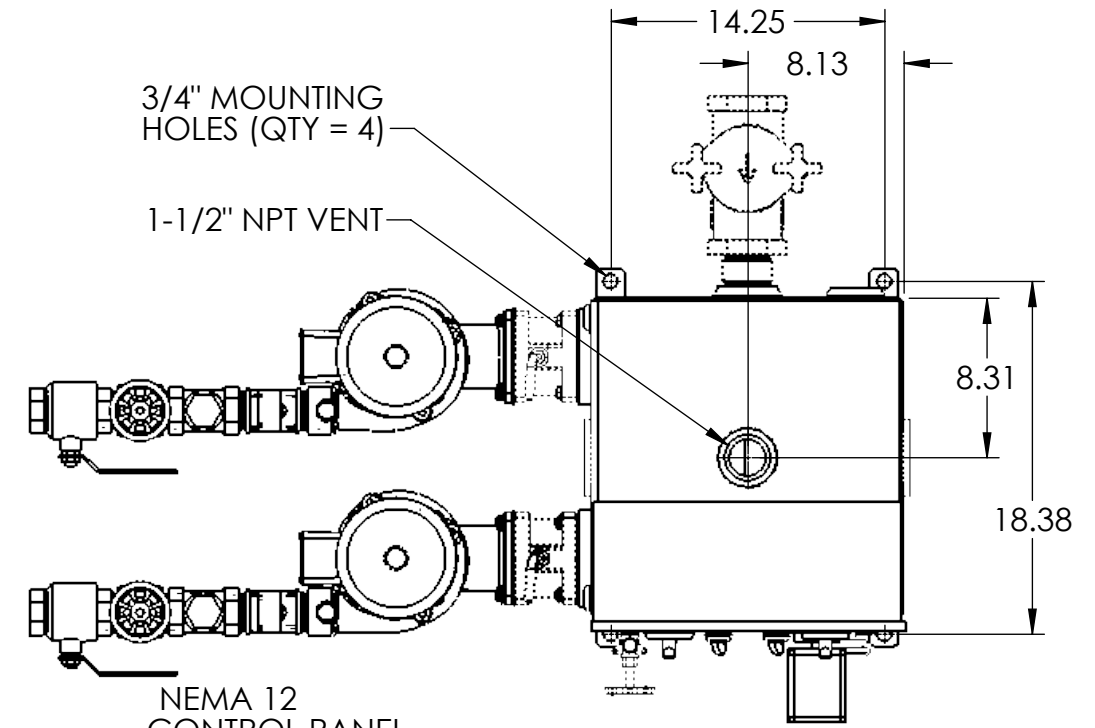
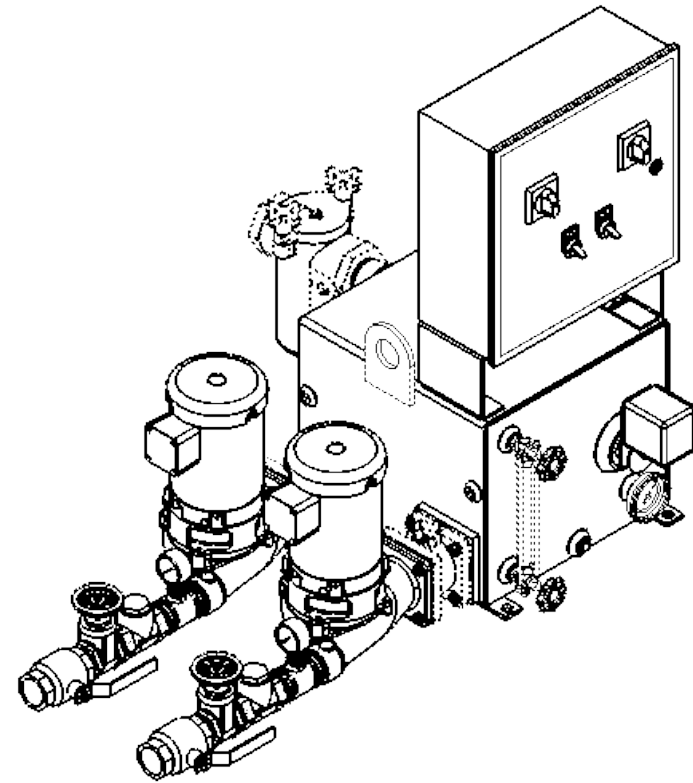

REV	DESCRIPTION	ECN	NAME	DATE
A	Initial Design		GJM	10/31/2017

PART NO:	684.48015.00	NAME	GJM	DATE	10/31/2017
FABRICATION TOLERANCES UNLESS OTHERWISE SPECIFIED: DIMENSIONS ARE IN INCHES	DRAWN	GJM	10/31/2017	THIRD ANGLE PROJECTION	
TOLERANCES: ANGULAR DIMENSIONS ±1° FRACTIONS ±1/32	CHECKED			TITLE	
TWO PLACE DECIMAL ±0.06 THREE PLACE DECIMAL ±0.030	ENG APPR.			15 GALLON DUPLEX 4800 SERIES "K" CONDENSATE PUMP	
	PRODUCT FAMILY	HTSP Boiler and Condensate			
	PRODUCT CATEGORY				
SHEET: 1 OF 1	WEIGHT	1257.76	DRAWING MAY NOT BE PRINTED TO SCALE.	DWG NO.	684.48015.00
	SCALE:	1:10		REV	A