

**NOTES:**

- TANK MATERIAL: STAINLESS STEEL
- ALL DIMENSIONS ARE ±0.25"
- DRAWING NOT FOR CONSTRUCTION
- CONSULT FACTORY AT TIME OF ORDER FOR CURRENT PRINT

**CONTROL PANEL OPTIONS ALSO AVAILABLE (NOT SHOWN):**

- NEMA 4 OR NEMA 4X OR NEMA 3R CONSTRUCTION
- ELECTRIC ALTERNATOR
- POWER ON LIGHT
- PUMP TEST BUTTON
- PUMP RUN TIME METER
- EXTRA DRY CONTACTS
- UL/CUL LABELED PANEL
- HIGH LEVEL ALARM HORN & LIGHT W/SILENCE SWITCH
- LEAD-AUTO-LAG SELECTOR SWITCH

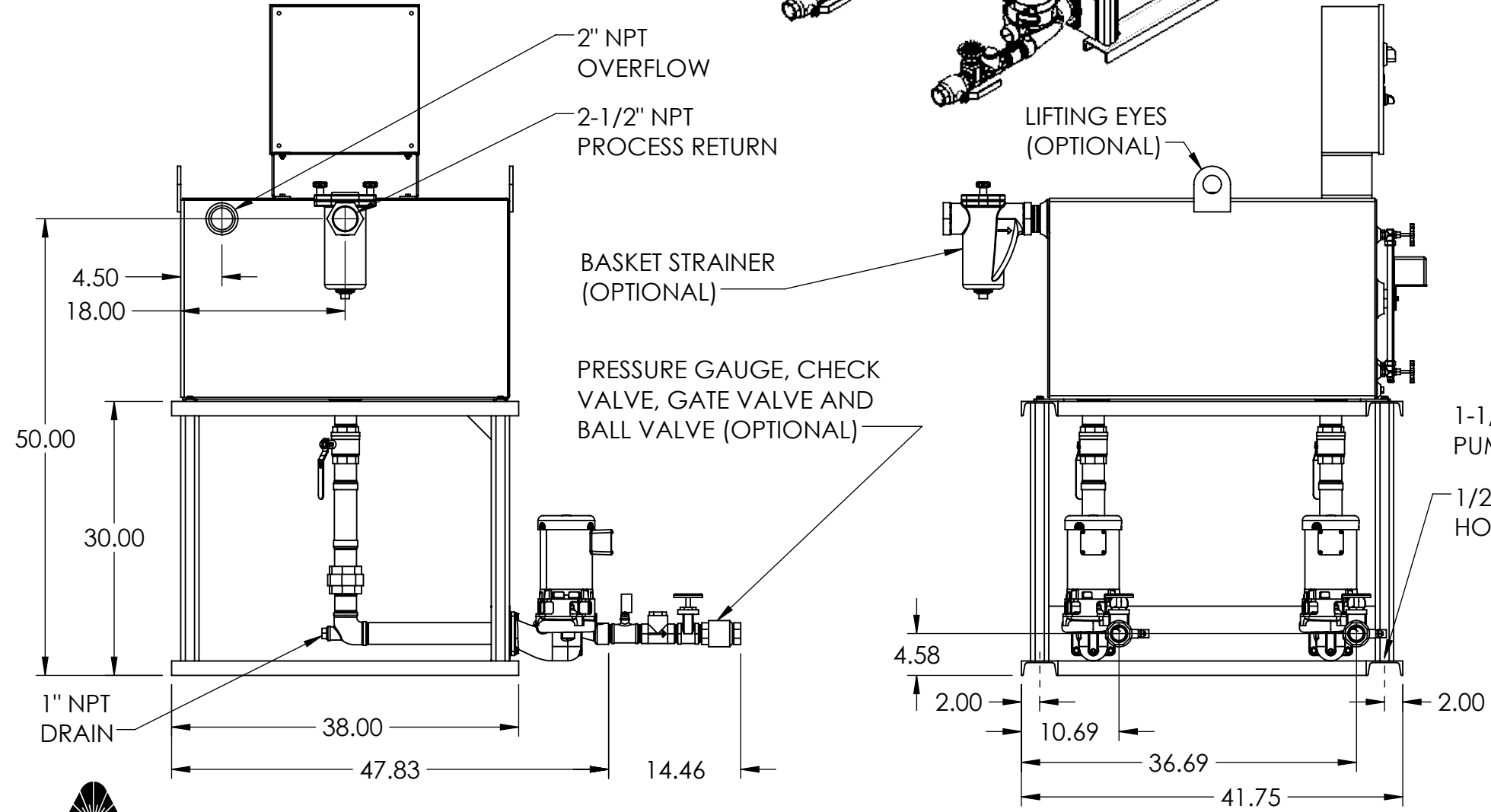
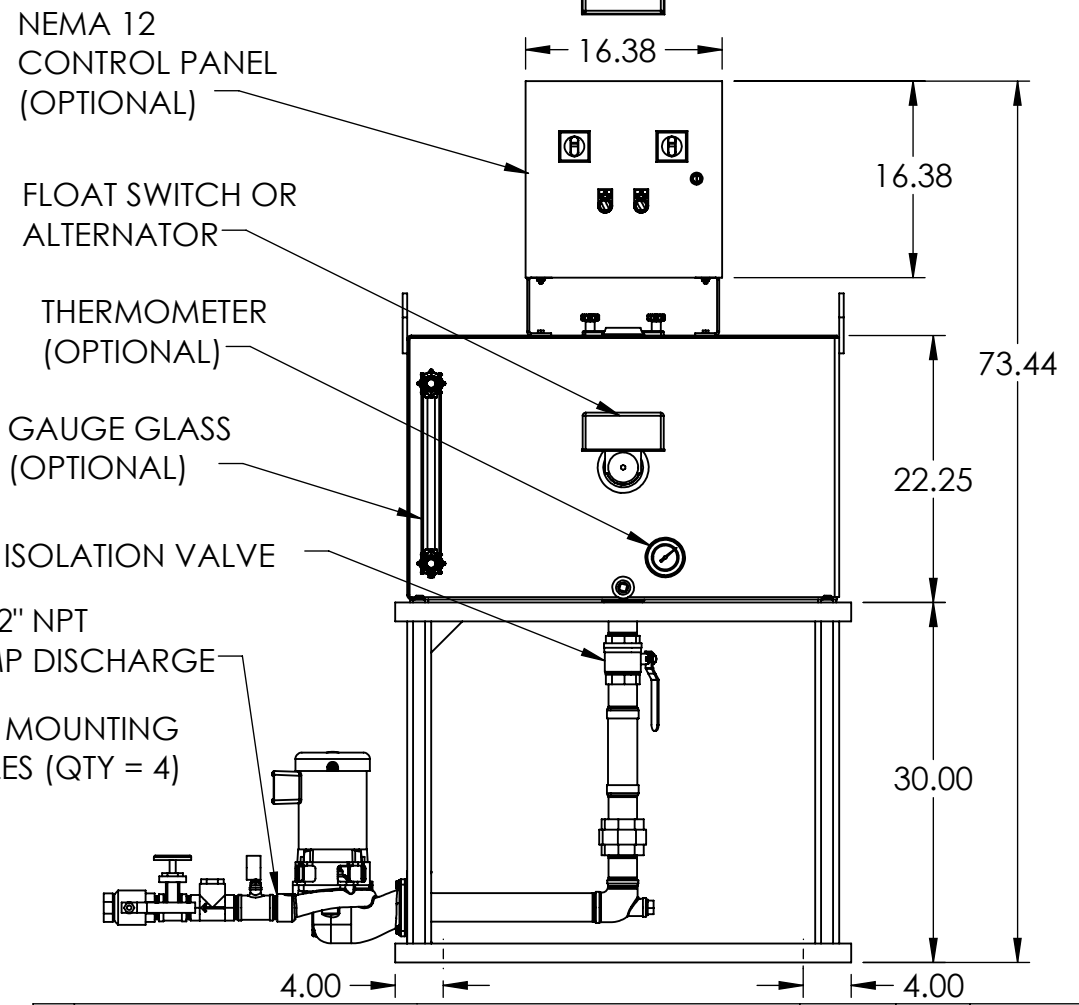
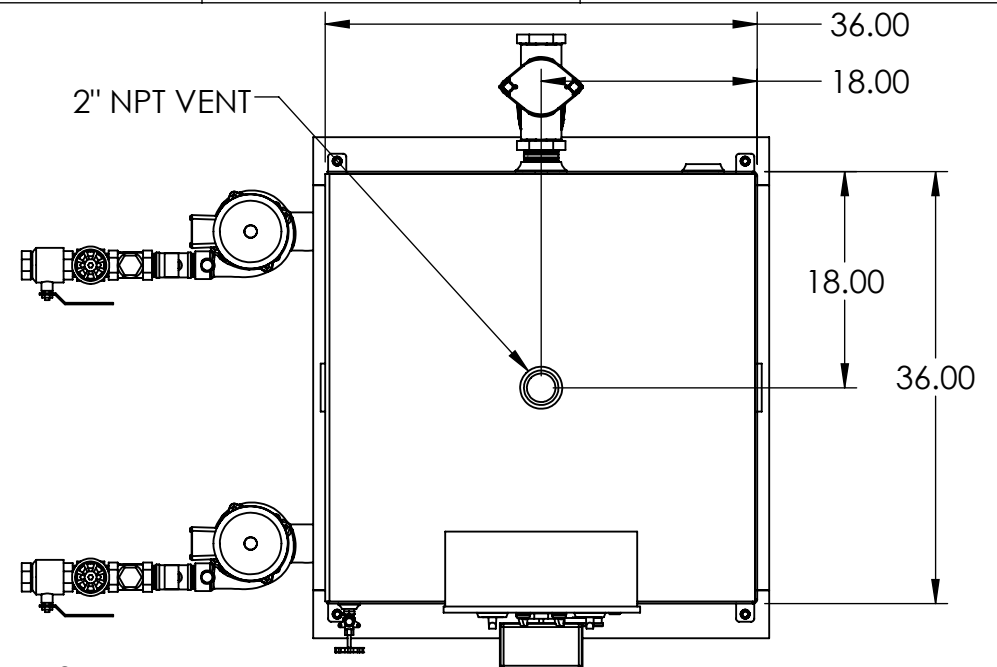
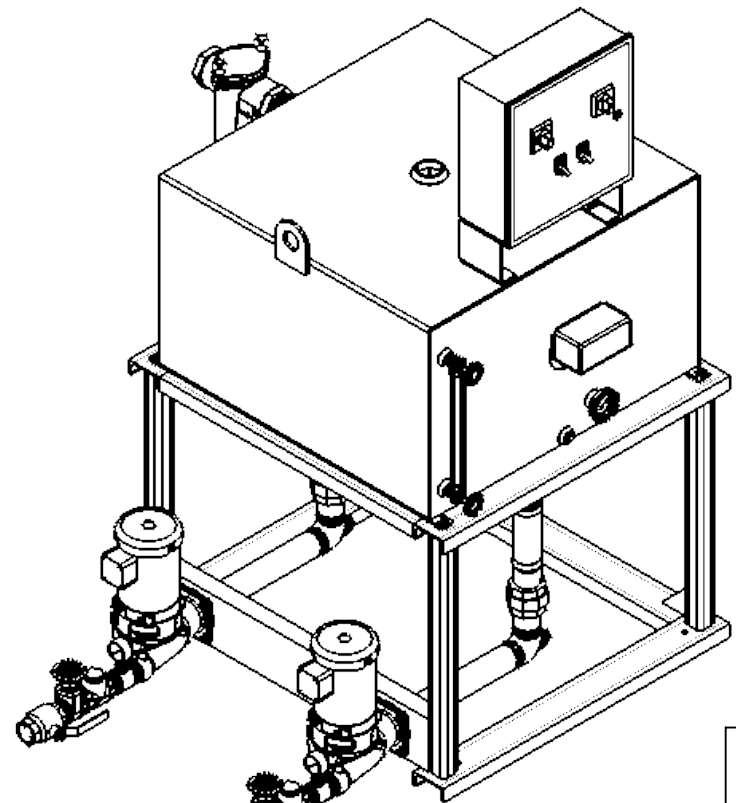

REV	DESCRIPTION	ECN	NAME	DATE
A	INITIAL DESIGN		GJM	11/1/2017

PART NO: 684.48120.10	NAME: GJM	DATE: 11/1/2017	 <b>TITLE</b> 120 GALLON DUPLEX 4800 SERIES, ELEVATED "K" CONDENSATE PUMP
FABRICATION TOLERANCES UNLESS OTHERWISE SPECIFIED: DIMENSIONS ARE IN INCHES	DRAWN		
TOLERANCES: ANGULAR DIMENSIONS ±1° FRACTIONS ±1/32	CHECKED		
TWO PLACE DECIMAL ±0.06 THREE PLACE DECIMAL ±0.030	ENG APPR.		
	PRODUCT FAMILY: HTSP Boiler and Condensate PRODUCT CATEGORY: 4600		DWG NO.: 684.48120.10 REV: A

SHEET: 1 OF 1	WEIGHT: 939.77	DRAWING MAY NOT BE PRINTED TO SCALE. SCALE: 1:16
---------------	----------------	--