

NOTES:

- TANK MATERIAL: CAST IRON PER ASTM A48 CLASS 30
- ALL DIMENSIONS ARE ±0.25"
- DRAWING NOT FOR CONSTRUCTION
- CONSULT FACTORY AT TIME OF ORDER FOR CURRENT PRINT

CONTROL PANEL OPTIONS ALSO AVAILABLE (NOT SHOWN):

- NEMA 4 OR NEMA 4X OR NEMA 3R CONSTRUCTION
- ELECTRIC ALTERNATOR
- POWER ON LIGHT
- PUMP TEST BUTTON
- PUMP RUN TIME METER
- EXTRA DRY CONTACTS
- UL/CUL LABELED PANEL
- HIGH LEVEL ALARM HORN & LIGHT W/SILENCE SWITCH
- LEAD-AUTO-LAG SELECTOR SWITCH

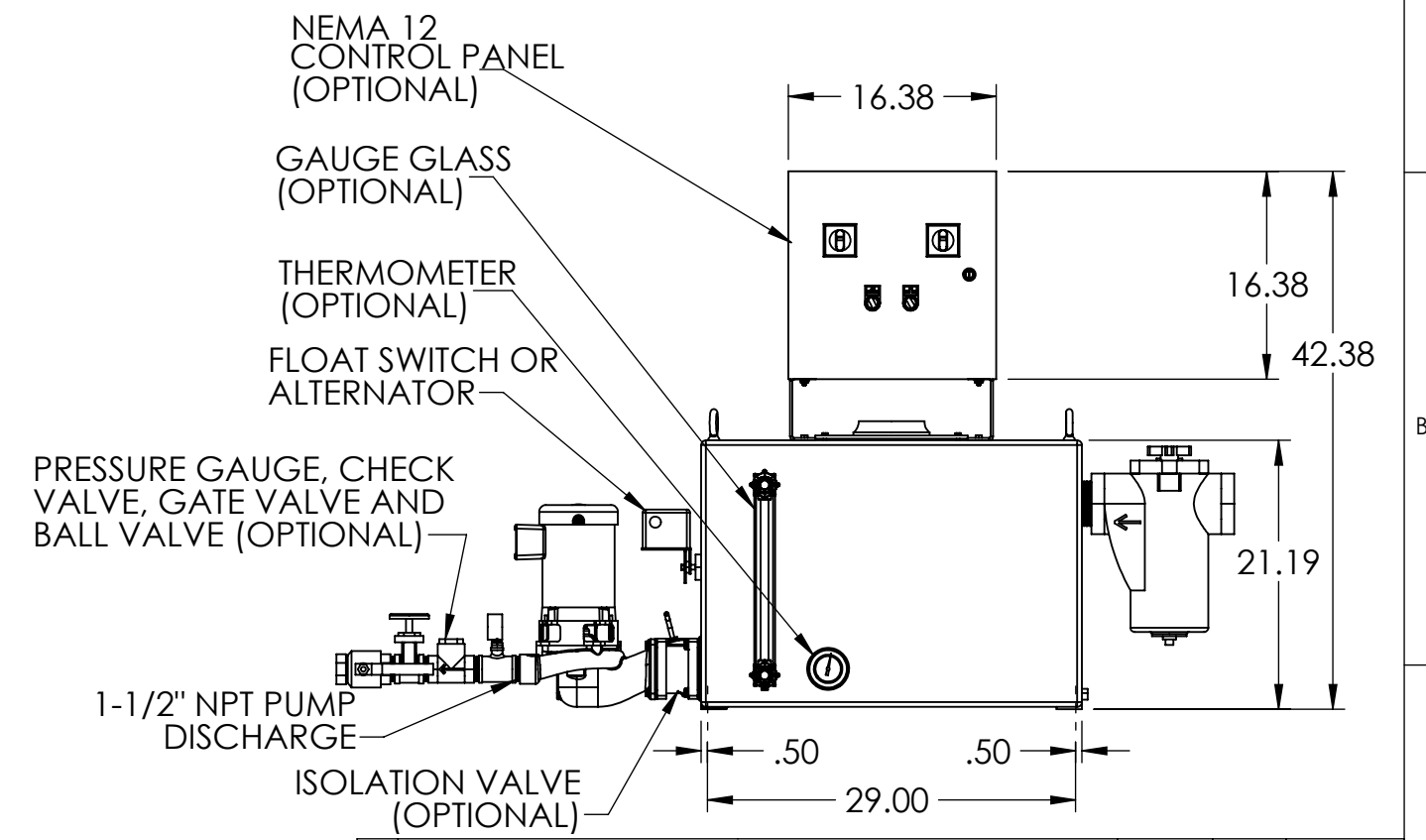
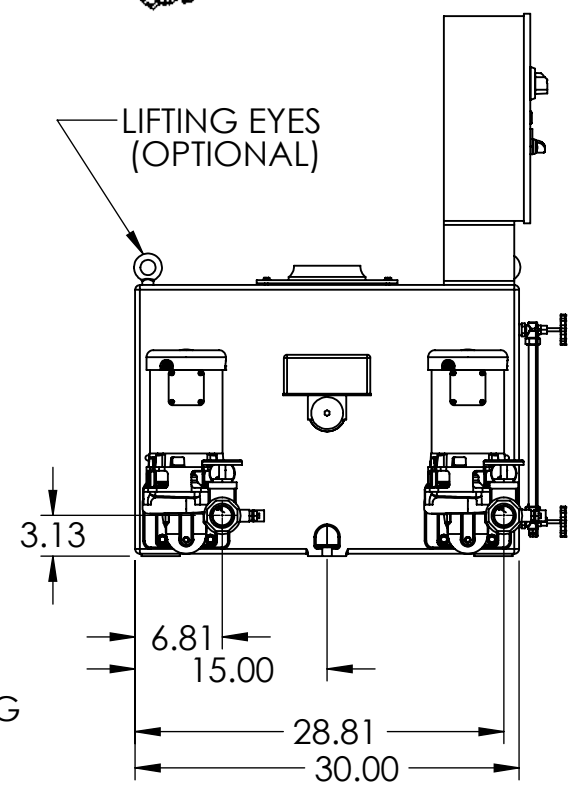
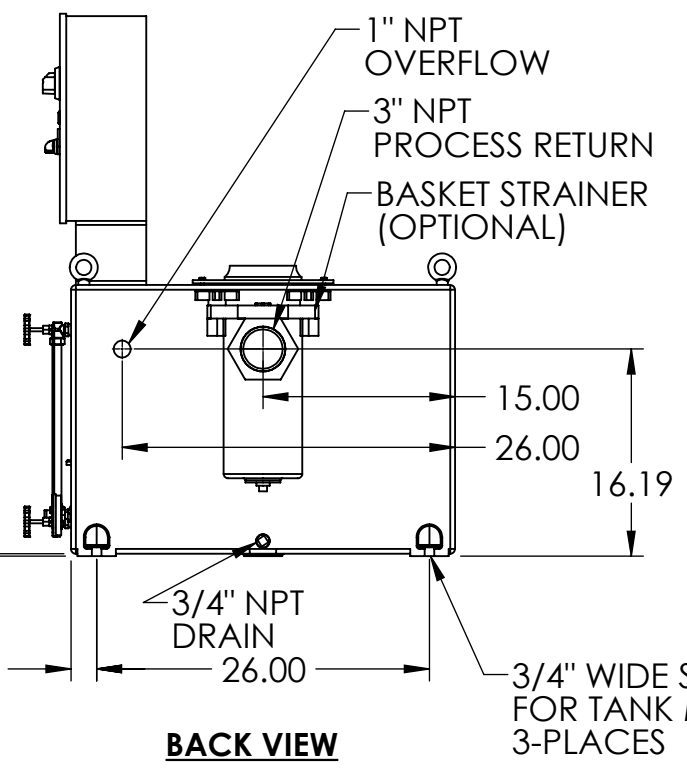
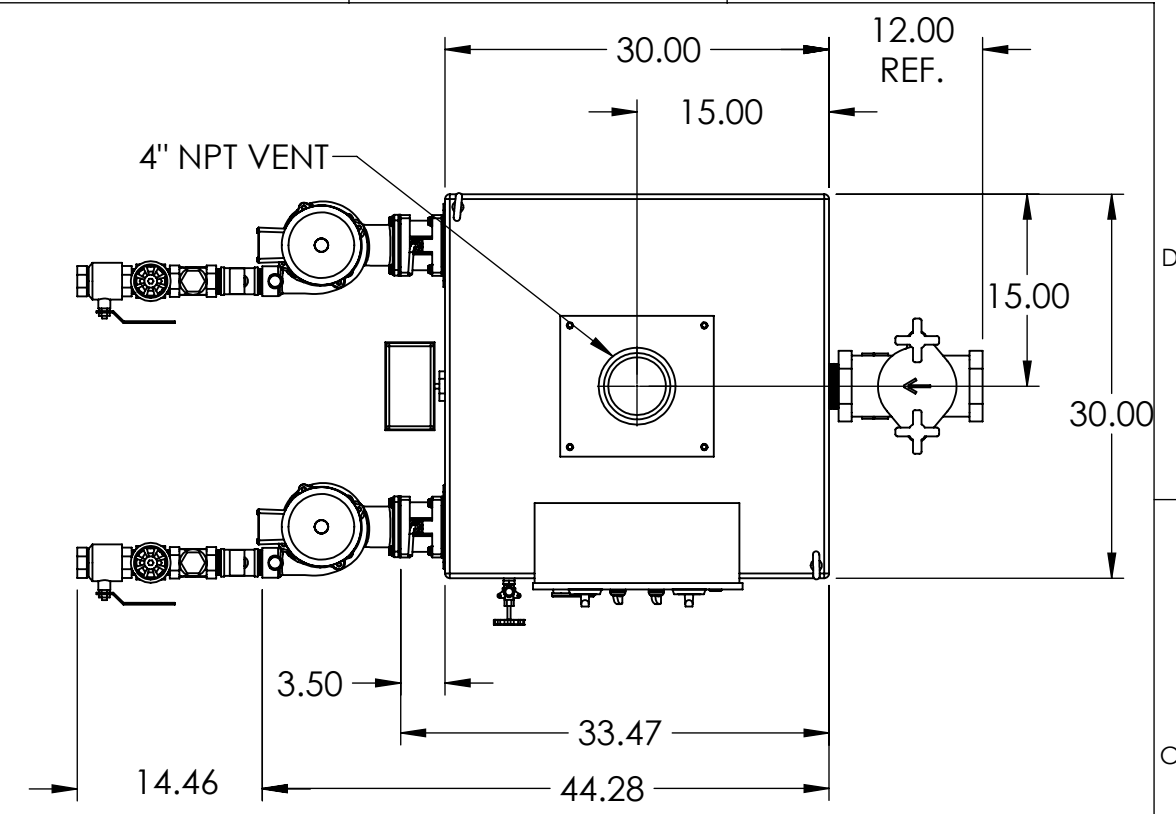
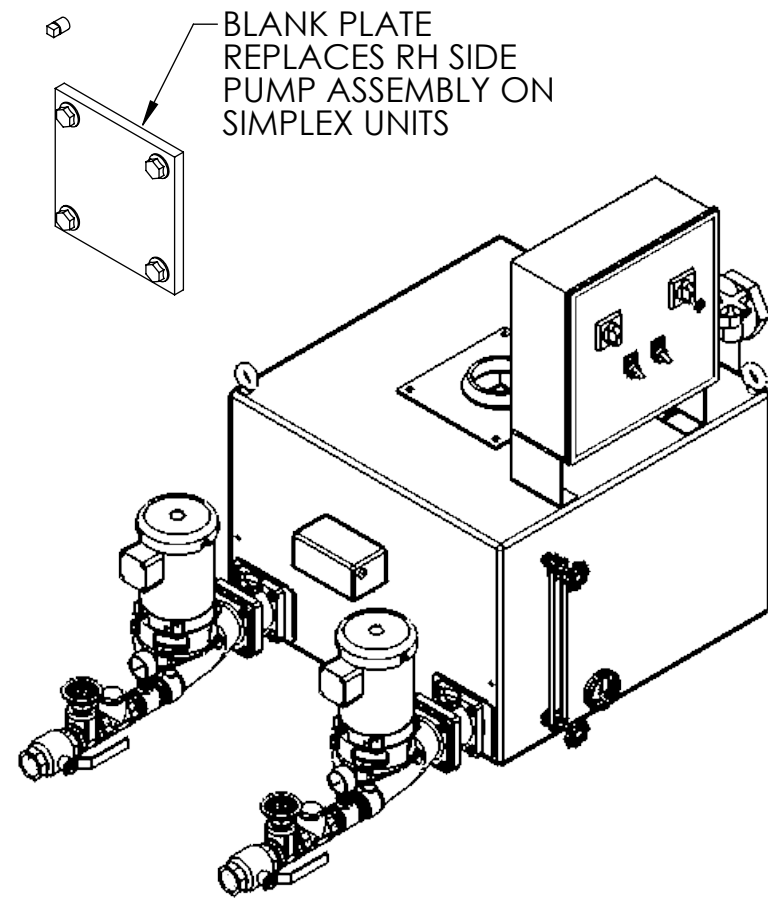

BACK VIEW

REV	DESCRIPTION	ECN	NAME	DATE
A	INITIAL DESIGN		GJM	2/19/2016

PART NO:	Ref PartNo	NAME	DATE
		GJM	2/19/2016

FABRICATION TOLERANCES UNLESS OTHERWISE SPECIFIED: DIMENSIONS ARE IN INCHES	DRAWN	ENG APPR.	THIRD ANGLE PROJECTION
	GJM		

TOLERANCES:	PRODUCT FAMILY	TITLE
ANGULAR DIMENSIONS ±1°	HTSP Boiler and Condensate	75 GALLON SIMPLEX/DUPLEX
FRACTIONS ±1/32		4700 SERIES
TWO PLACE DECIMAL ±0.06		"K" CONDENSATE PUMP
THREE PLACE DECIMAL ±0.030	PRODUCT CATEGORY	
	4200	

SHEET: 1 OF 1	WEIGHT	DRAWING MAY NOT BE PRINTED TO SCALE.	DWG NO.	REV
	750.42	SCALE: 1:15	684.47075.00	A

