

**NOTES:**

- TANK MATERIAL: CAST IRON PER ASTM A48 CLASS 30
- ALL DIMENSIONS ARE ±0.25"
- DRAWING NOT FOR CONSTRUCTION
- CONSULT FACTORY AT TIME OF ORDER FOR CURRENT PRINT

**CONTROL PANEL OPTIONS ALSO AVAILABLE (NOT SHOWN):**

- NEMA 4 OR NEMA 4X OR NEMA 3R CONSTRUCTION
- ELECTRIC ALTERNATOR
- POWER ON LIGHT
- PUMP TEST BUTTON
- PUMP RUN TIME METER
- EXTRA DRY CONTACTS
- UL/CUL LABELED PANEL
- HIGH LEVEL ALARM HORN & LIGHT W/SILENCE SWITCH
- LEAD-AUTO-LAG SELECTOR

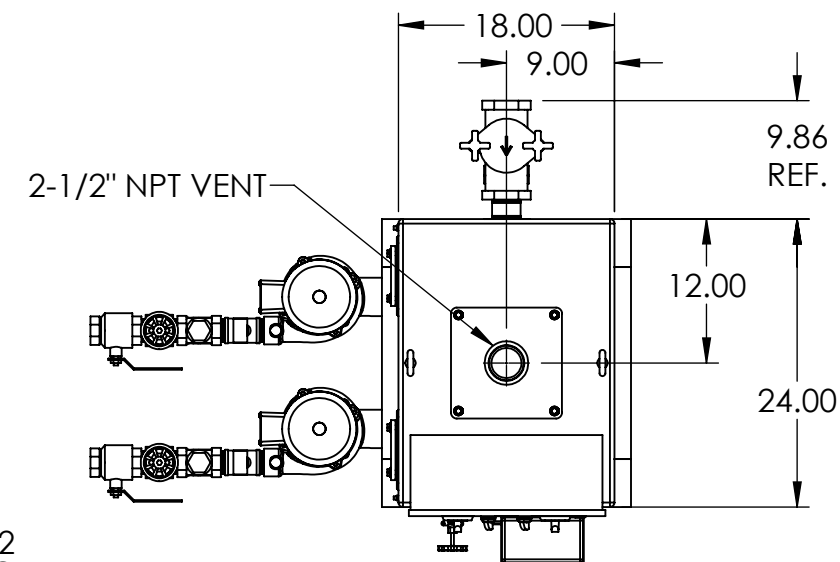
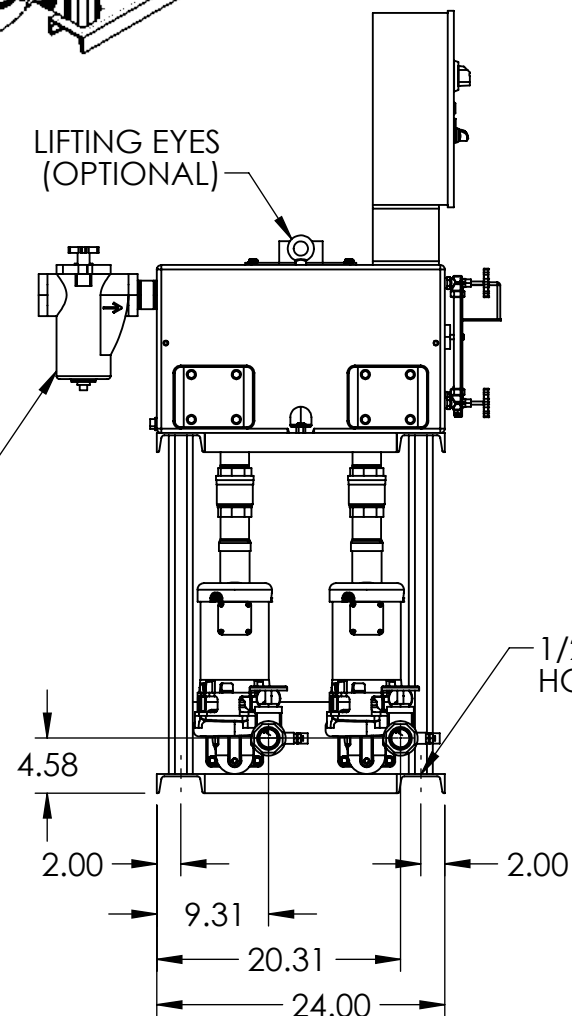
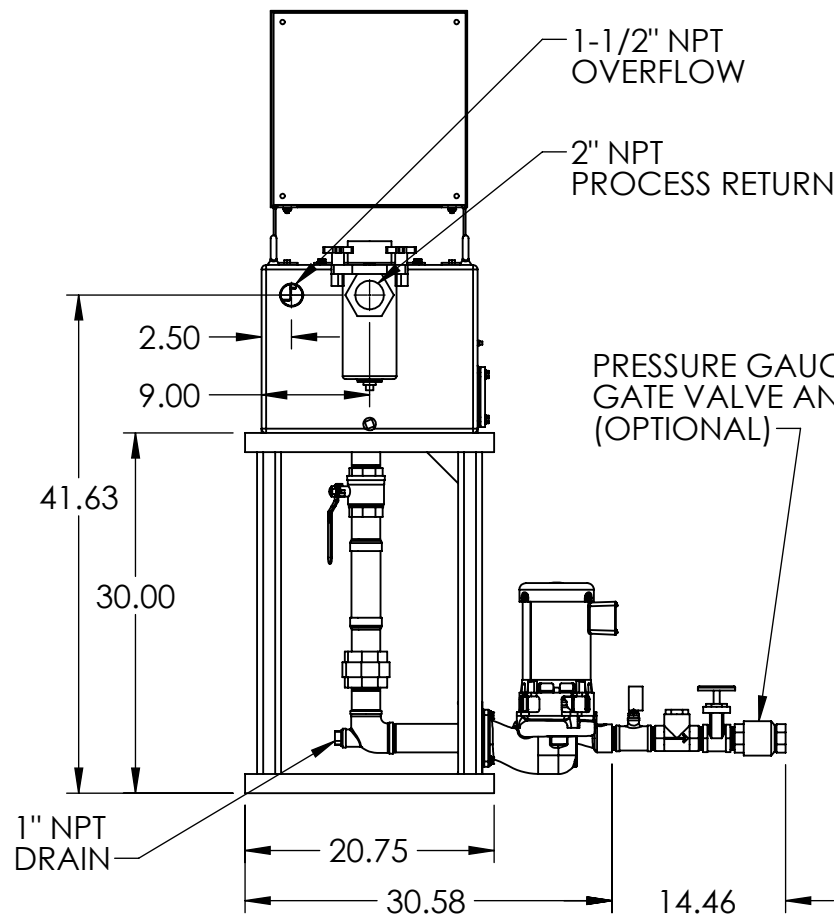
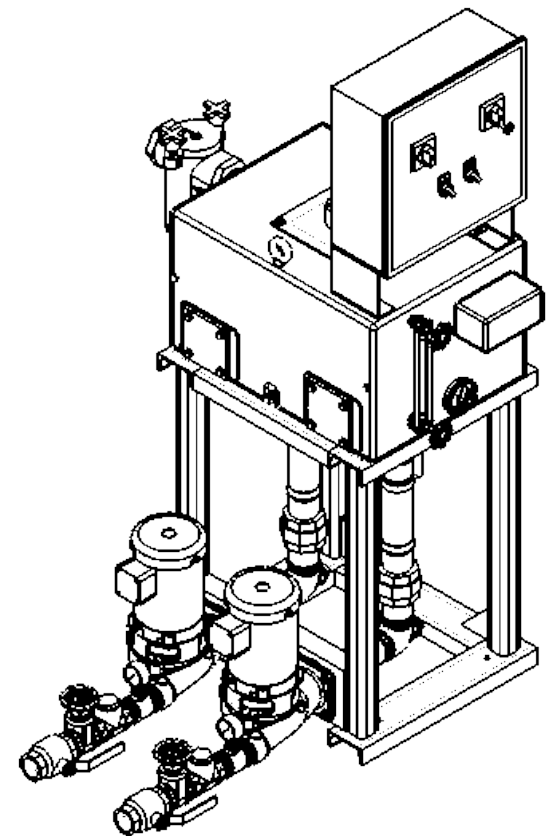

NEMA 12 CONTROL PANEL (OPTIONAL)

FLOAT SWITCH OR ALTERNATOR

GAUGE GLASS (OPTIONAL)

THERMOMETER (OPTIONAL)

ISOLATION VALVE

1-1/2" NPT PUMP DISCHARGE

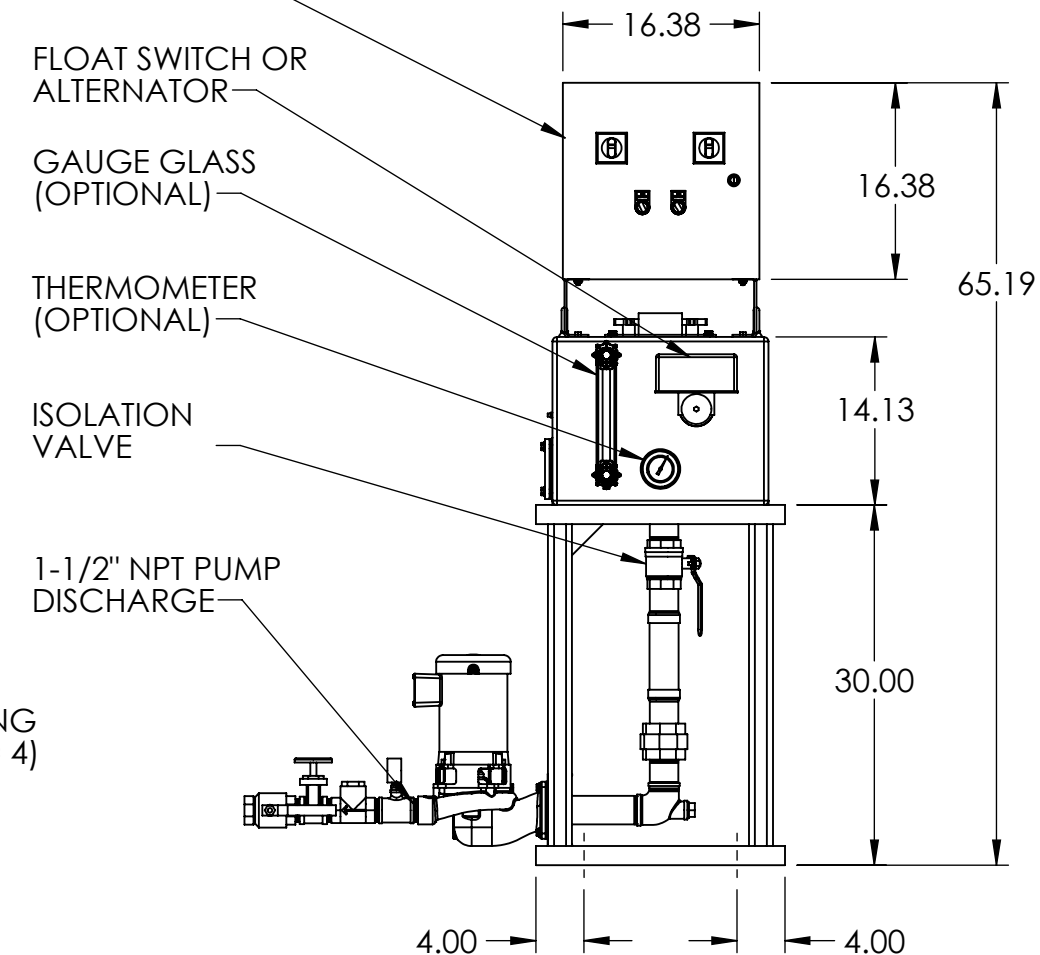

REV	DESCRIPTION	ECN	NAME	DATE
A	Initial Design		GJM	2/19/2016

PART NO:	Ref PartNo	NAME	DATE
		GJM	2/19/2016

FABRICATION TOLERANCES UNLESS OTHERWISE SPECIFIED: DIMENSIONS ARE IN INCHES  TOLERANCES: ANGULAR DIMENSIONS ±1° FRACTIONS ±1/32  TWO PLACE DECIMAL ±0.06 THREE PLACE DECIMAL ±0.030	DRAWN	GJM	2/19/2016	THIRD ANGLE PROJECTION  TITLE <b>24 GALLON DUPLEX 4700 SERIES, ELEVATED "K" CONDENSATE PUMP</b>  PRODUCT FAMILY HTSP Boiler and Condensate  PRODUCT CATEGORY 4200
	CHECKED			
	ENG APPR.			
	PRODUCT CATEGORY	4200		

SHEET: 1 OF 1	WEIGHT	DRAWING MAY NOT BE PRINTED TO SCALE.	DWG NO.	REV
		SCALE: 1:16	684.47024.10	A

