

NOTES:

- TANK MATERIAL: STEEL
- ALL DIMENSIONS ARE ±0.25"
- DRAWING NOT FOR CONSTRUCTION
- CONSULT FACTORY AT TIME OF ORDER FOR CURRENT PRINT

CONTROL PANEL OPTIONS ALSO AVAILABLE (NOT SHOWN):

- NEMA 4 OR NEMA 4X OR NEMA 3R CONSTRUCTION
- ELECTRIC ALTERNATOR
- POWER ON LIGHT
- PUMP TEST BUTTON
- PUMP RUN TIME METER
- EXTRA DRY CONTACTS
- UL/CUL LABELED PANEL
- HIGH LEVEL ALARM HORN & LIGHT W/SILENCE SWITCH
- LEAD-AUTO-LAG SELECTOR SWITCH

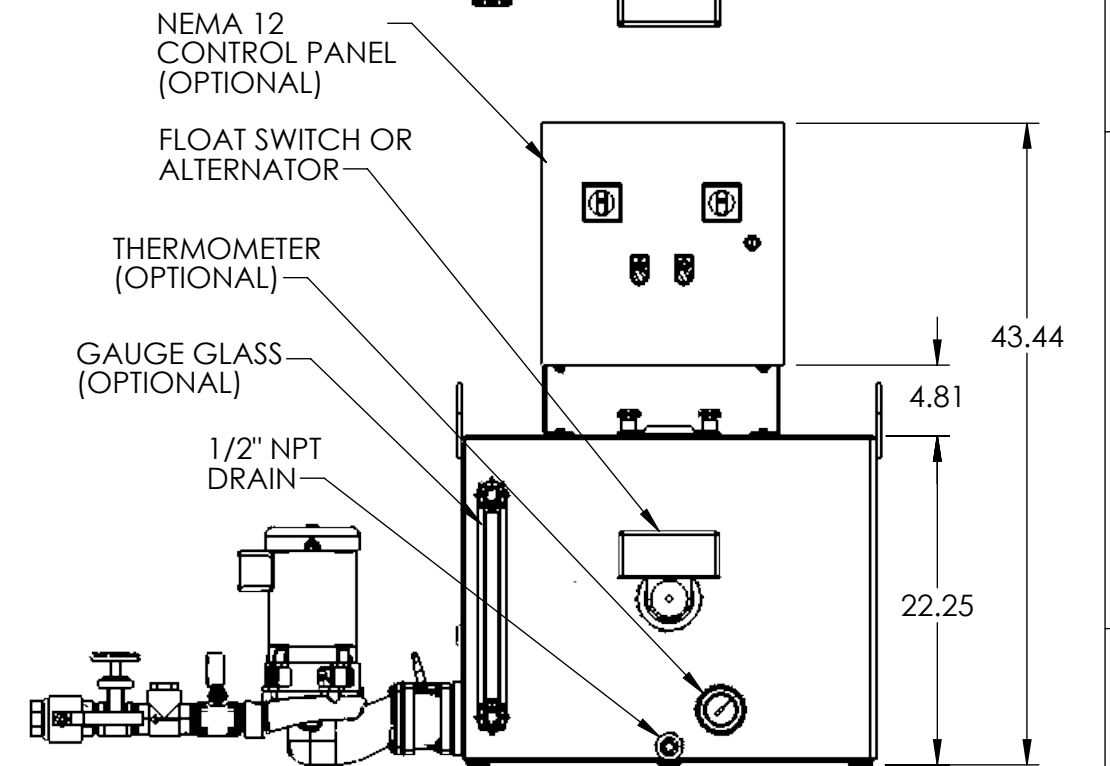
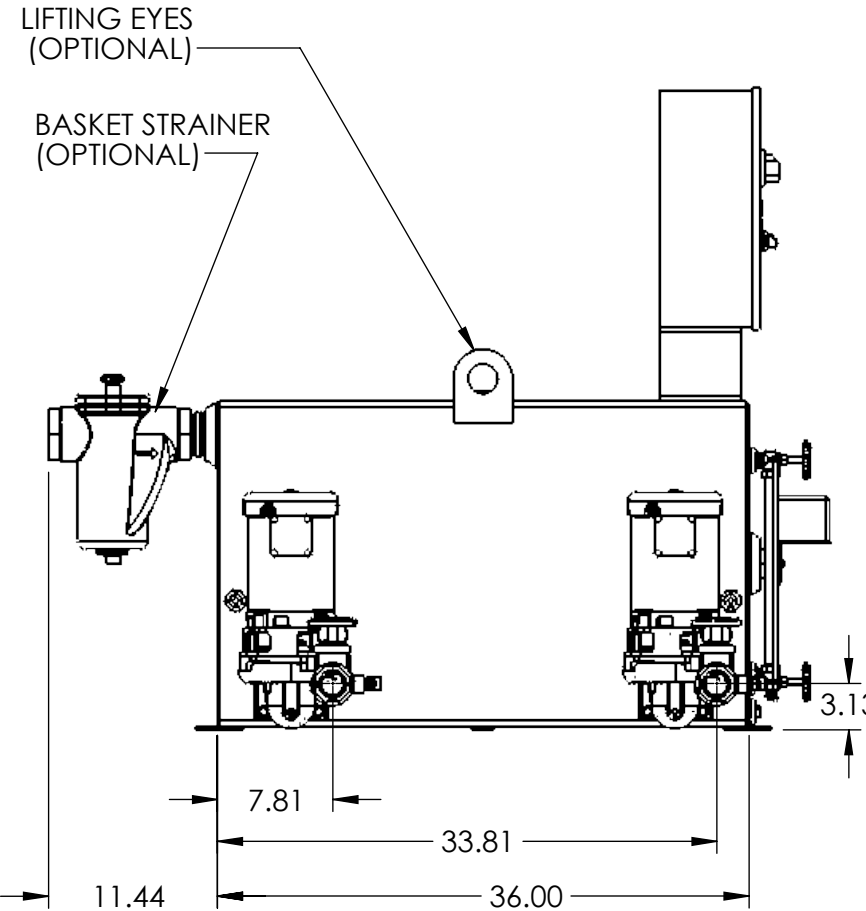
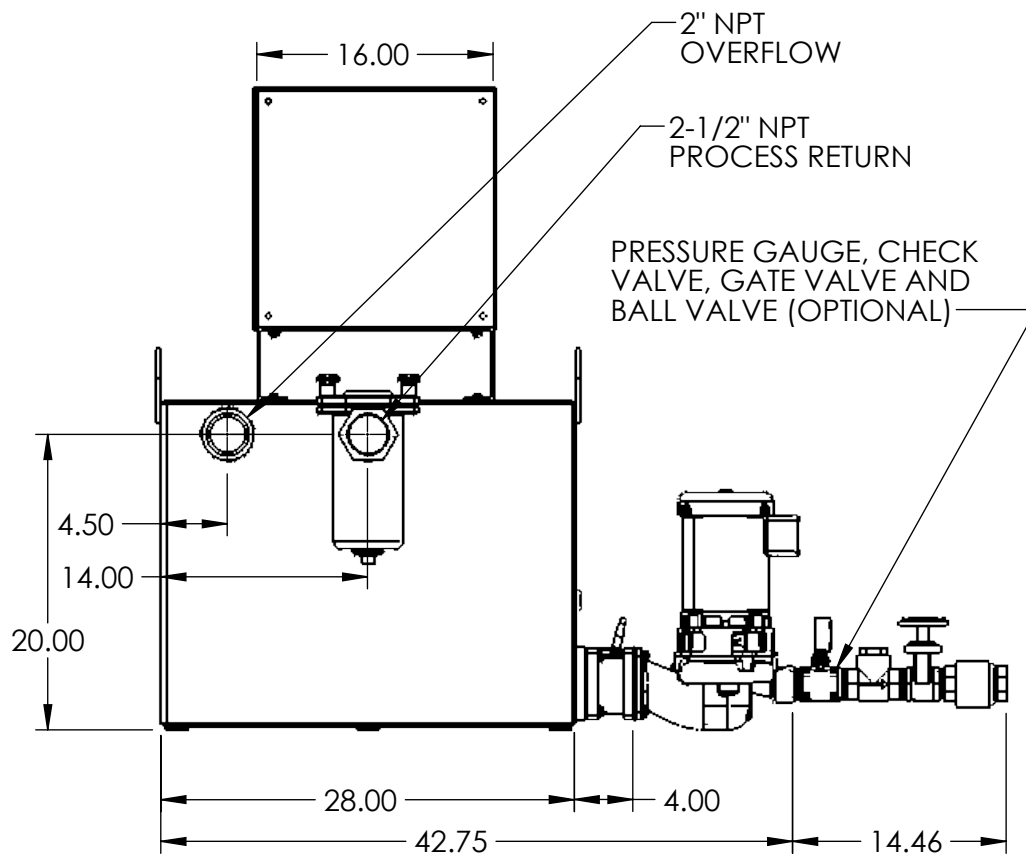
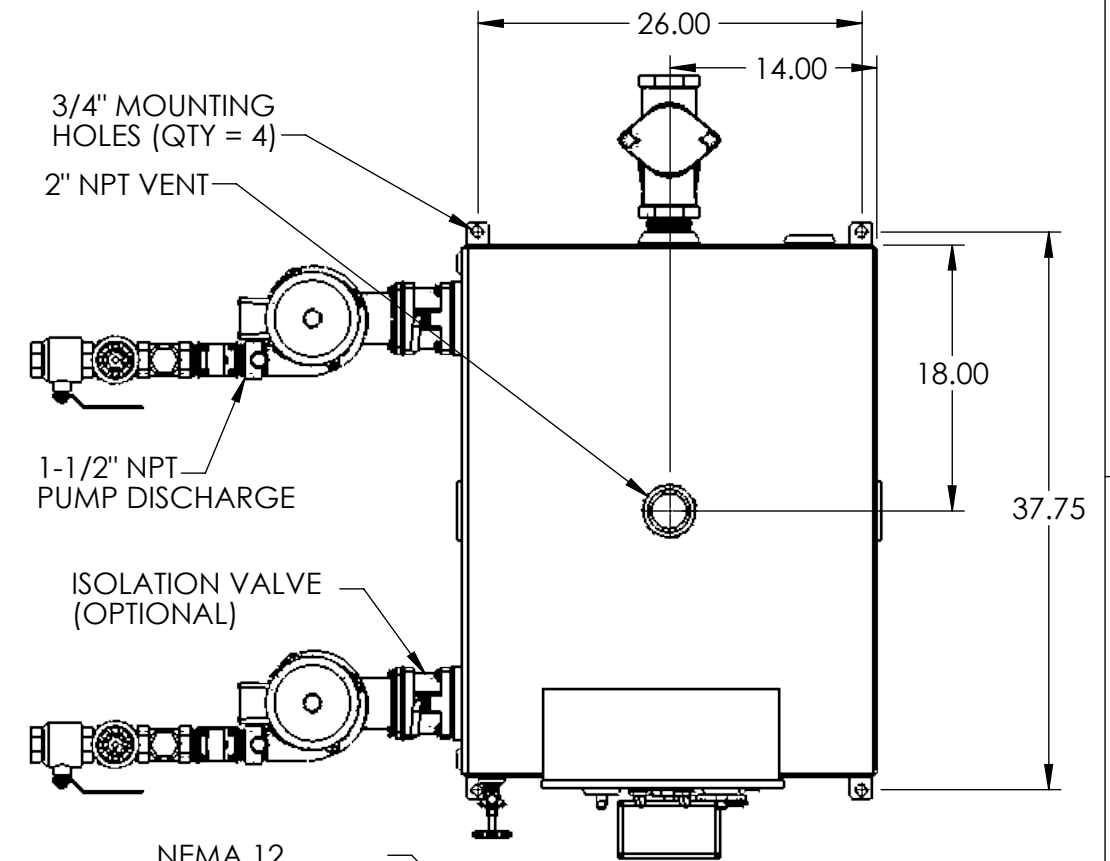
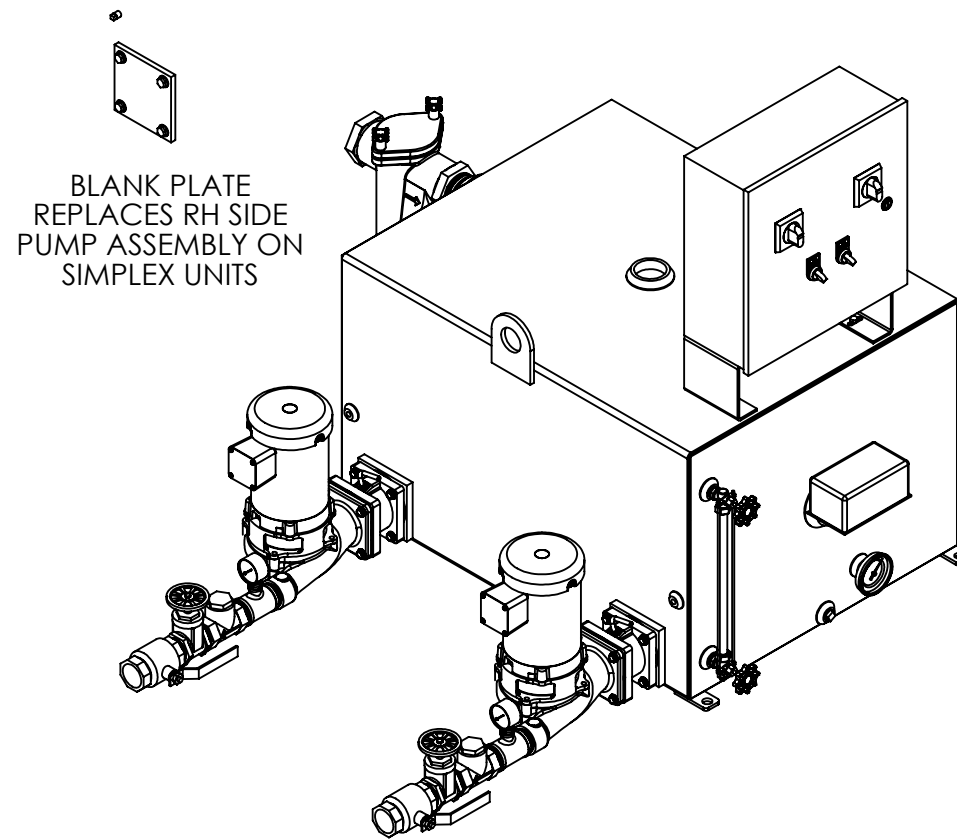

REV	DESCRIPTION	ECN	NAME	DATE
A	Initial Design		GJM	10/31/2017
PART NO: 684.46095.00		NAME	DATE	
DRAWN		GJM	10/31/2017	
CHECKED				
ENG APPR.				
TOLERANCES: ANGULAR DIMENSIONS ±1° FRACTIONS ±1/32		THIRD ANGLE PROJECTION		
TWO PLACE DECIMAL ±0.06 THREE PLACE DECIMAL ±0.030		TITLE		
		95 GALLON SIMPLEX/DUPLEX 4600 SERIES "K" CONDENSATE PUMP		
SHEET: 1 OF 1		WEIGHT	DRAWING MAY NOT BE PRINTED TO SCALE.	DWG NO.
		459.94	SCALE: 1:13	684.46095.00
				REV
				A

