

**NOTES:**

- TANK MATERIAL: STEEL
- ALL DIMENSIONS ARE ±0.25"
- DRAWING NOT FOR CONSTRUCTION
- CONSULT FACTORY AT TIME OF ORDER FOR CURRENT PRINT

**CONTROL PANEL OPTIONS ALSO AVAILABLE (NOT SHOWN):**

- NEMA 4 OR NEMA 4X OR NEMA 3R CONSTRUCTION
- ELECTRIC ALTERNATOR
- POWER ON LIGHT
- PUMP TEST BUTTON
- PUMP RUN TIME METER
- EXTRA DRY CONTACTS
- UL/CUL LABELED PANEL
- HIGH LEVEL ALARM HORN & LIGHT W/SILENCE SWITCH
- LEAD-AUTO-LAG SELECTOR SWITCH

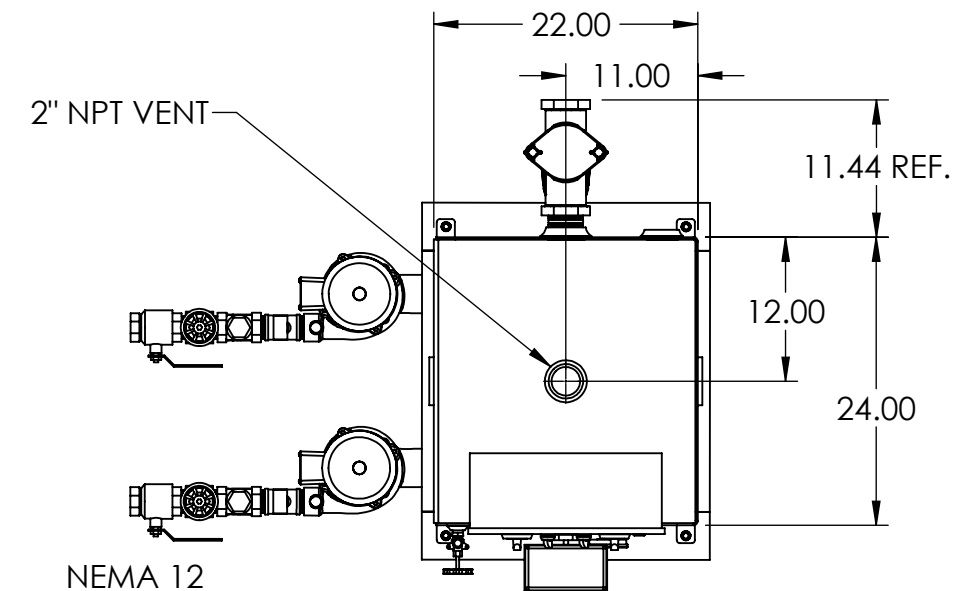
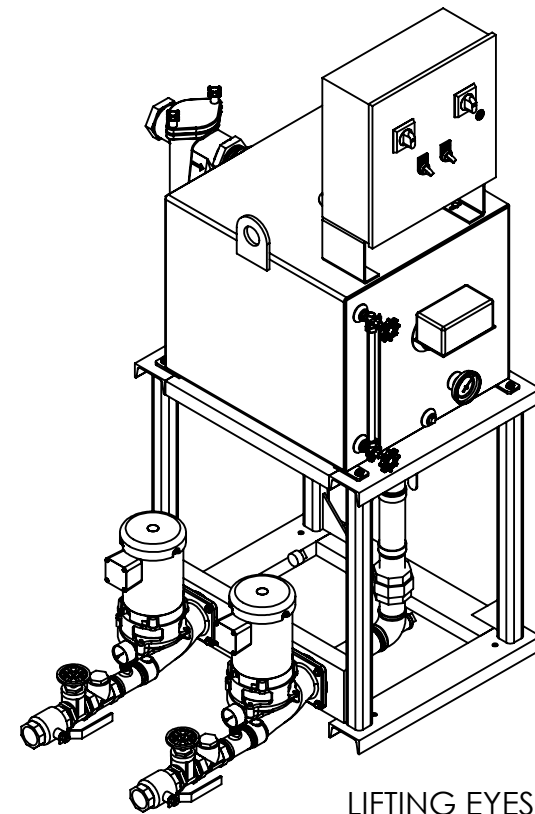

2" NPT VENT  
NEMA 12 CONTROL PANEL (OPTIONAL)

FLOAT SWITCH OR ALTERNATOR

THERMOMETER (OPTIONAL)

GAUGE GLASS (OPTIONAL)

ISOLATION VALVE

1-1/2" NPT PUMP DISCHARGE

1/2" MOUNTING HOLES (QTY = 4)

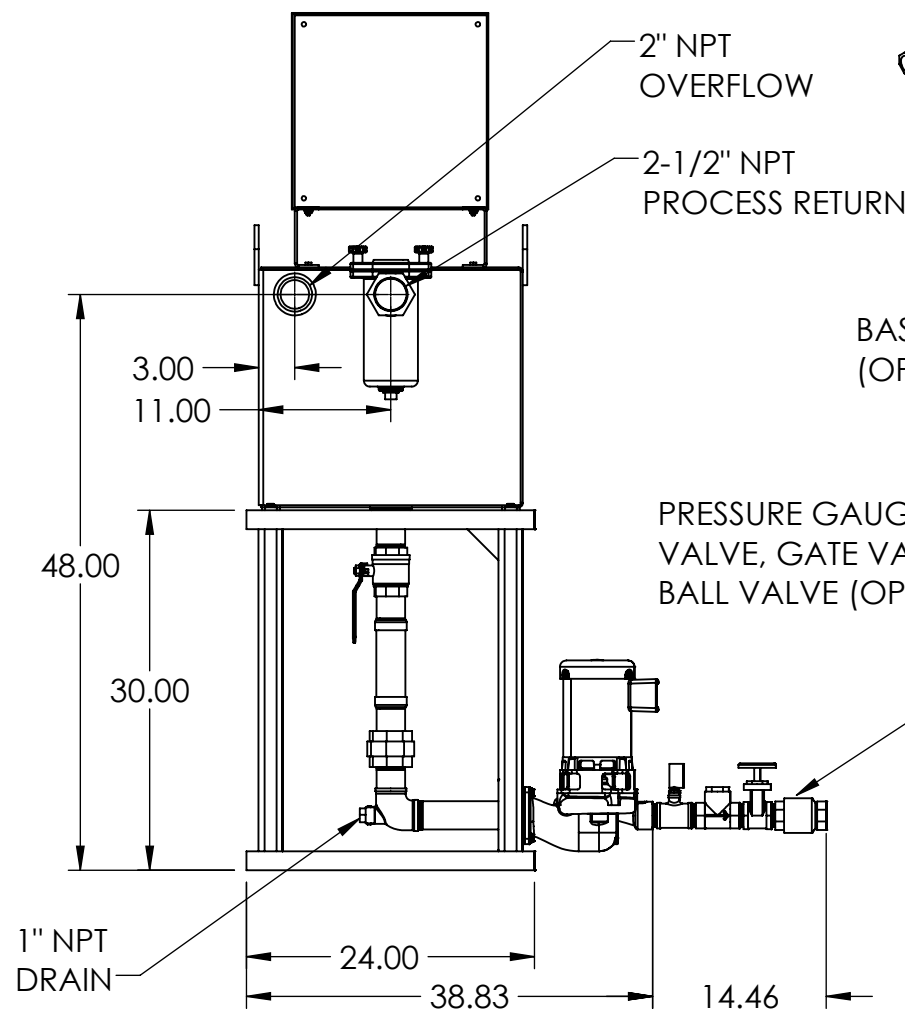

2" NPT OVERFLOW

2-1/2" NPT PROCESS RETURN

BASKET STRAINER (OPTIONAL)

PRESSURE GAUGE, CHECK VALVE, GATE VALVE AND BALL VALVE (OPTIONAL)

1" NPT DRAIN

LIFTING EYES (OPTIONAL)

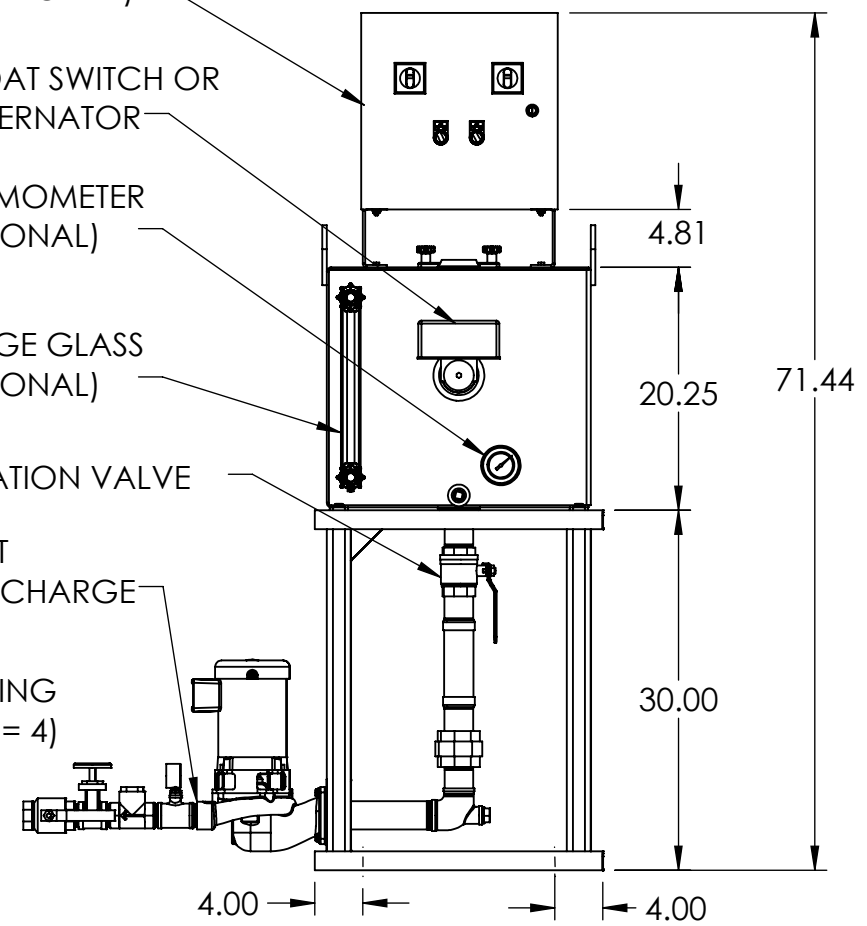
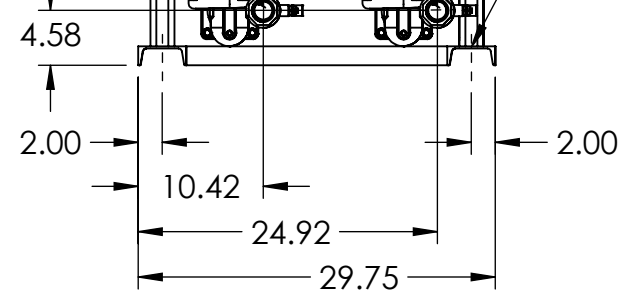

REV	DESCRIPTION	ECN	NAME	DATE
A	INITIAL DESIGN		GJM	11/1/2017

PART NO: 684.46045.10	NAME: GJM	DATE: 11/1/2017	 THIRD ANGLE PROJECTION TITLE <b>45 GALLON DUPLEX 4600 SERIES, ELEVATED "K" CONDENSATE PUMP</b>
FABRICATION TOLERANCES UNLESS OTHERWISE SPECIFIED: DIMENSIONS ARE IN INCHES	DRAWN		
TOLERANCES: ANGULAR DIMENSIONS ±1° FRACTIONS ±1/32	CHECKED		
TWO PLACE DECIMAL ±0.06 THREE PLACE DECIMAL ±0.030	ENG APPR.		
PRODUCT FAMILY: HTSP Boiler and Condensate		PRODUCT CATEGORY: 4600	
SHEET: 1 OF 1	WEIGHT: 3593.67	DRAWING MAY NOT BE PRINTED TO SCALE. SCALE: 1:16	DWG NO. 684.46045.10

