

NOTES:

- TANK MATERIAL: STEEL
- ALL DIMENSIONS ARE ±0.25"
- DRAWING NOT FOR CONSTRUCTION
- CONSULT FACTORY AT TIME OF ORDER FOR CURRENT PRINT

CONTROL PANEL OPTIONS ALSO AVAILABLE (NOT SHOWN):

- NEMA 4 OR NEMA 4X OR NEMA 3R CONSTRUCTION
- POWER ON LIGHT
- PUMP TEST BUTTON
- PUMP RUN TIME METER
- EXTRA DRY CONTACTS
- UL/CUL LABELED PANEL
- HIGH LEVEL ALARM HORN & LIGHT W/SILENCE SWITCH

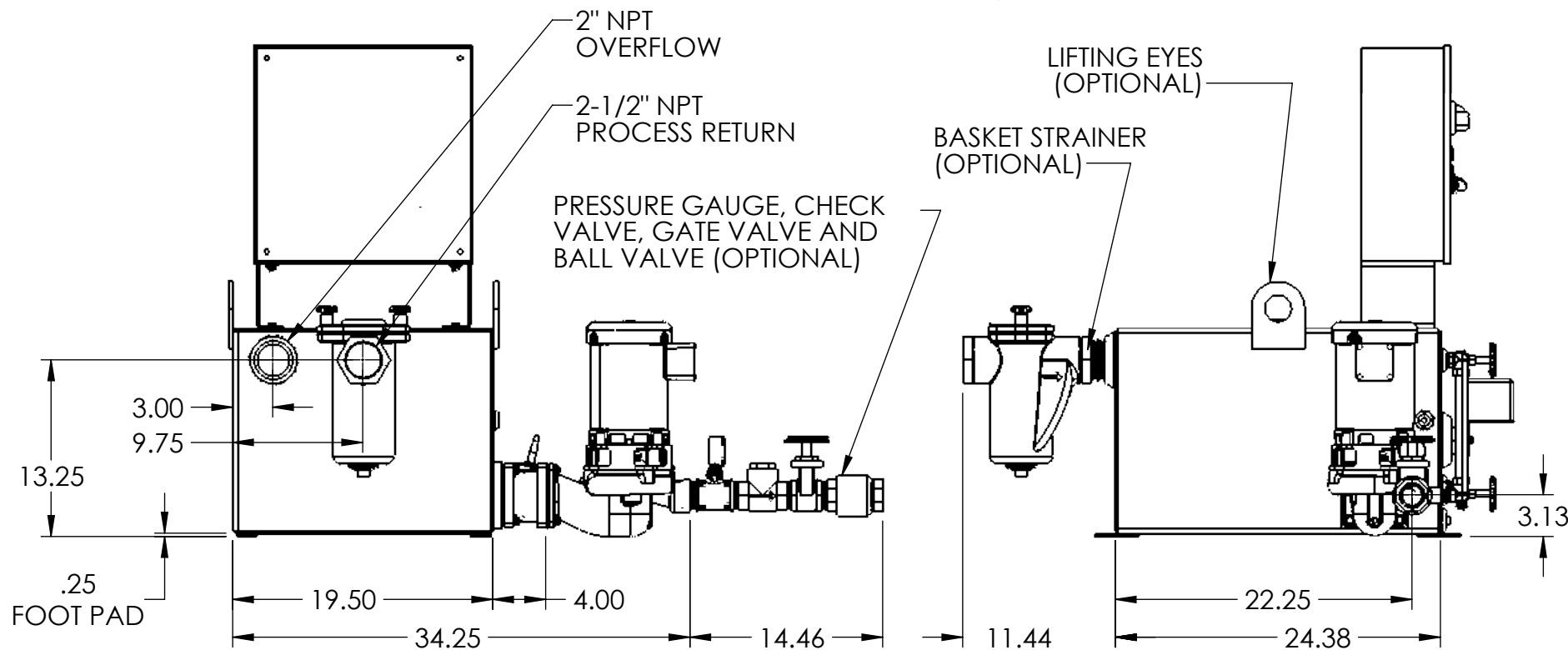
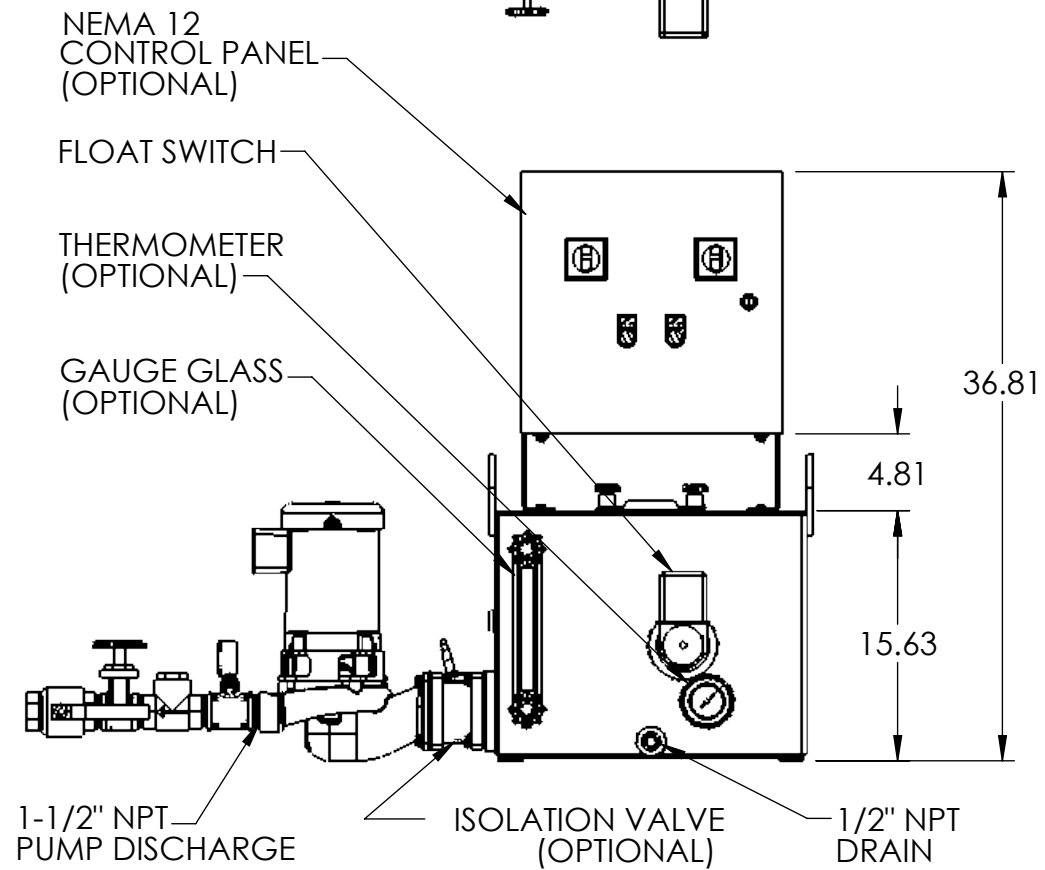
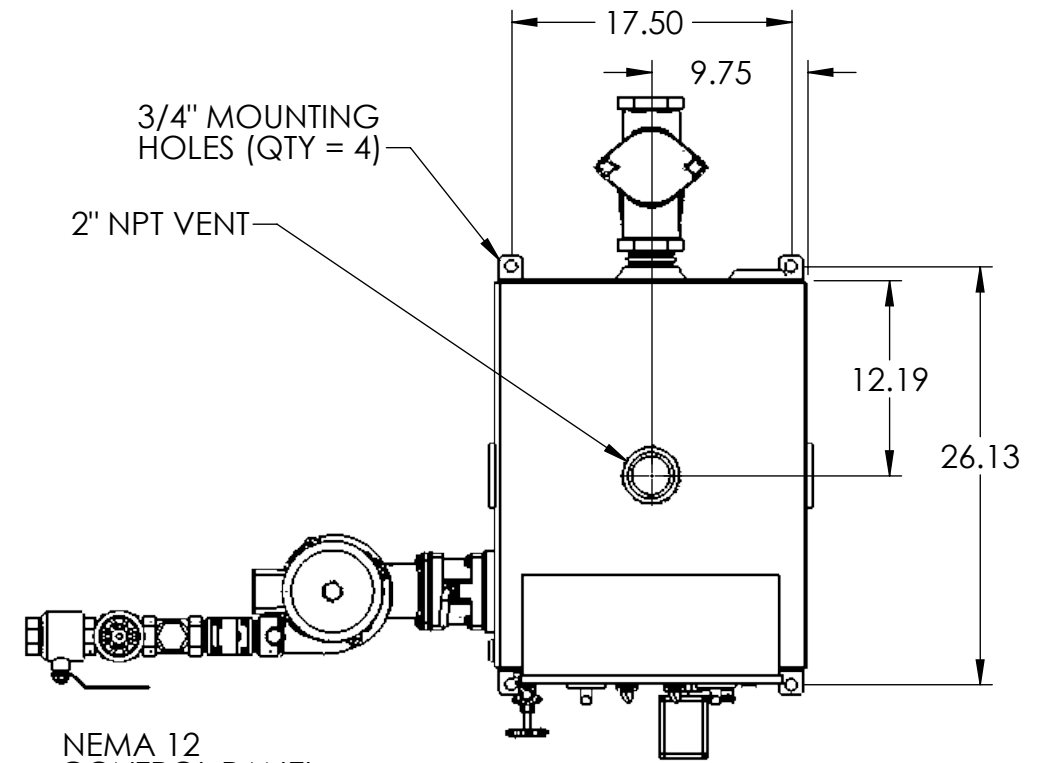
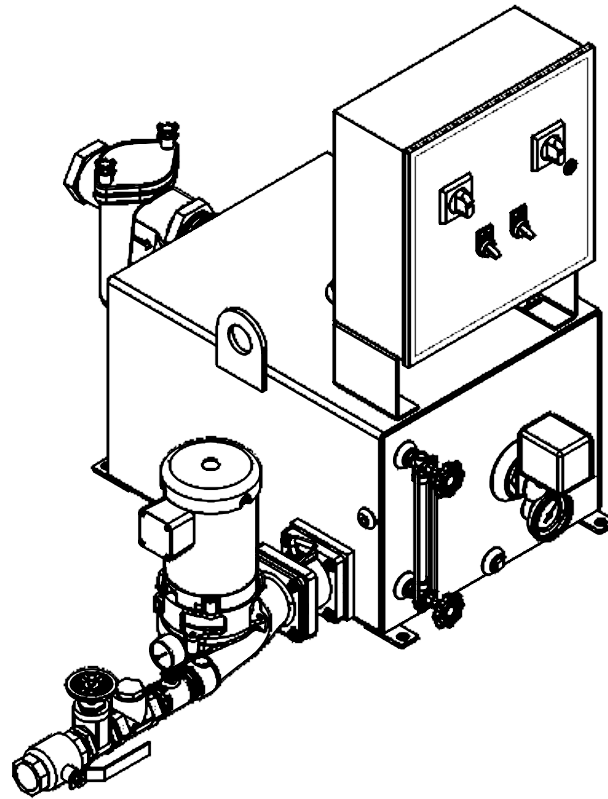

REV	DESCRIPTION	ECN	NAME	DATE
A	Initial Design		GJM	10/31/2017

PART NO: 684.46030.01	NAME	DATE	 TITLE 30 GALLON SIMPLEX 4600 SERIES "K" CONDENSATE PUMP	
FABRICATION TOLERANCES UNLESS OTHERWISE SPECIFIED: DIMENSIONS ARE IN INCHES	DRAWN	GJM 10/31/2017		
TOLERANCES: ANGULAR DIMENSIONS ±1° FRACTIONS ±1/32	CHECKED			
TWO PLACE DECIMAL ±0.06 THREE PLACE DECIMAL ±0.030	ENG APPR.			
	PRODUCT FAMILY HTSP Boiler and Condensate			
	PRODUCT CATEGORY			
SHEET: 1 OF 1	WEIGHT 2244.48	DRAWING MAY NOT BE PRINTED TO SCALE. SCALE: 1:12	DWG NO. 684.46030.01	REV A

