

**NOTES:**

- TANK MATERIAL: STEEL
- ALL DIMENSIONS ARE ±0.25"
- DRAWING NOT FOR CONSTRUCTION
- CONSULT FACTORY AT TIME OF ORDER FOR CURRENT PRINT

**CONTROL PANEL OPTIONS ALSO AVAILABLE (NOT SHOWN):**

- NEMA 4 OR NEMA 4X OR NEMA 3R CONSTRUCTION
- ELECTRIC ALTERNATOR
- POWER ON LIGHT
- PUMP TEST BUTTON
- PUMP RUN TIME METER
- EXTRA DRY CONTACTS
- UL/CUL LABELED PANEL
- HIGH LEVEL ALARM HORN & LIGHT W/SILENCE SWITCH
- LEAD-AUTO-LAG SELECTOR SWITCH

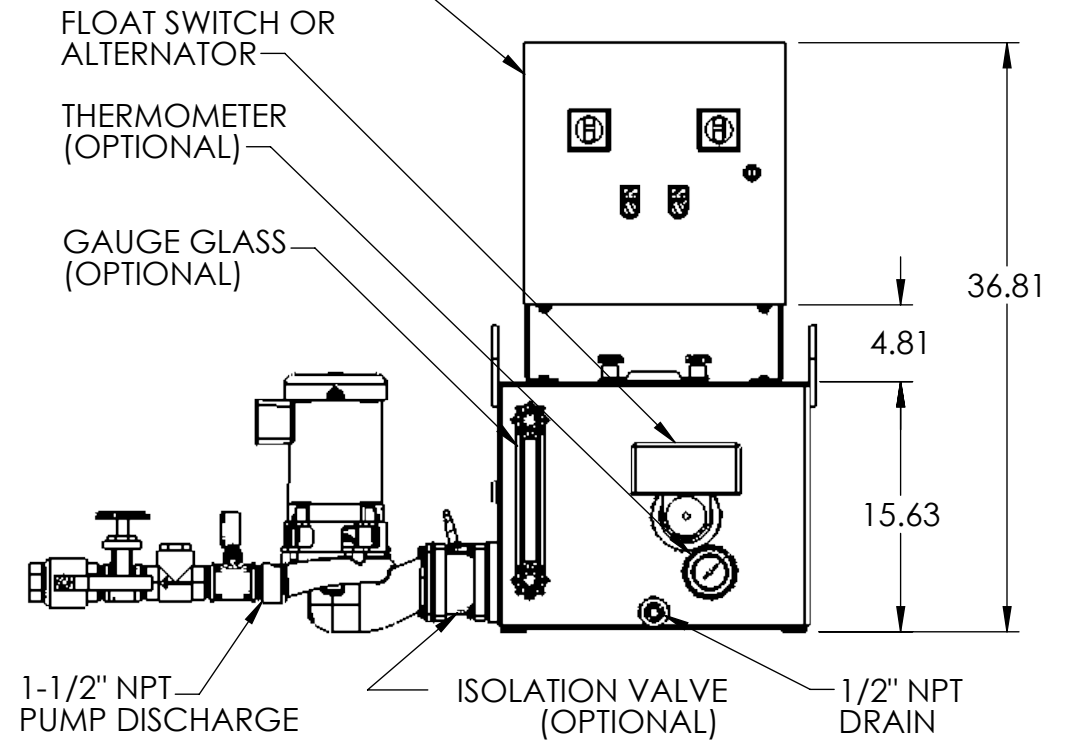
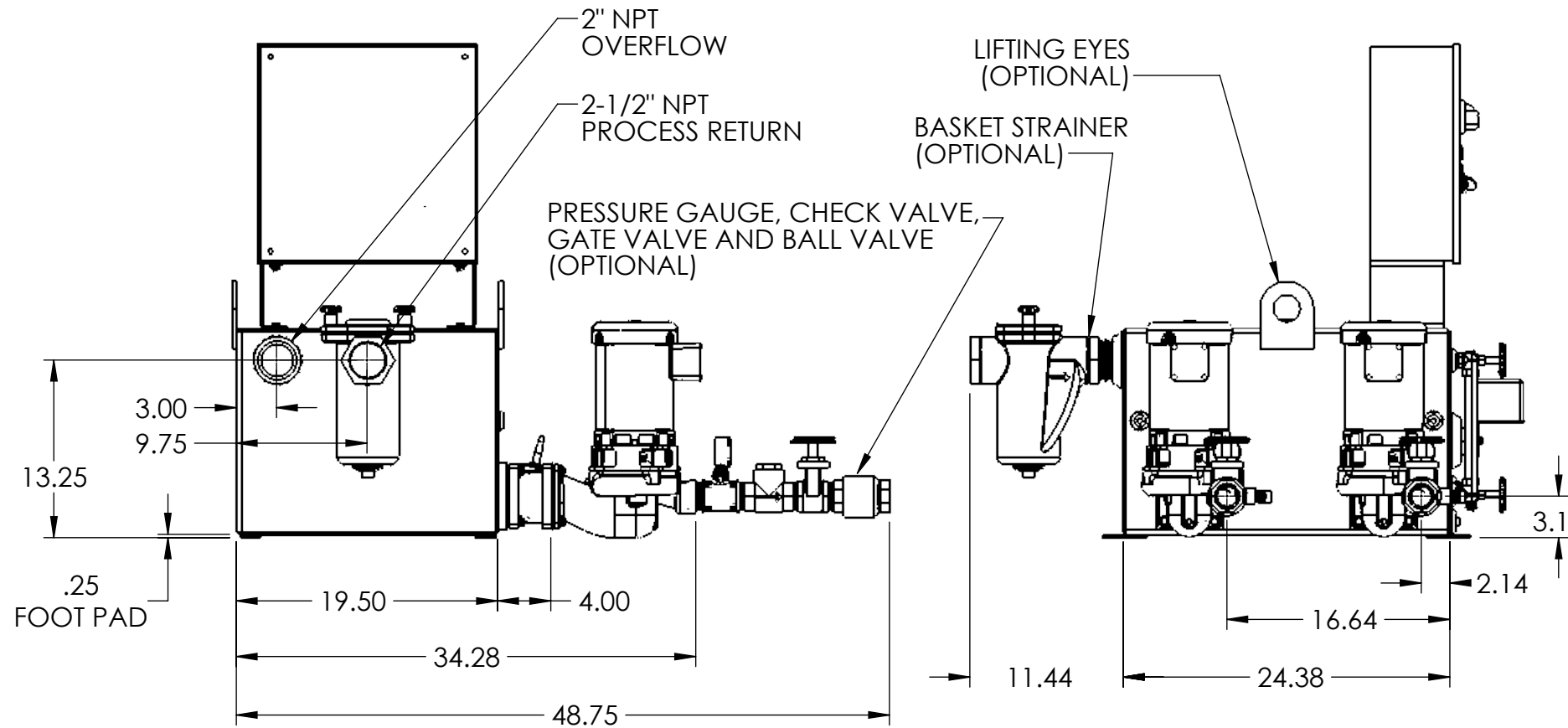
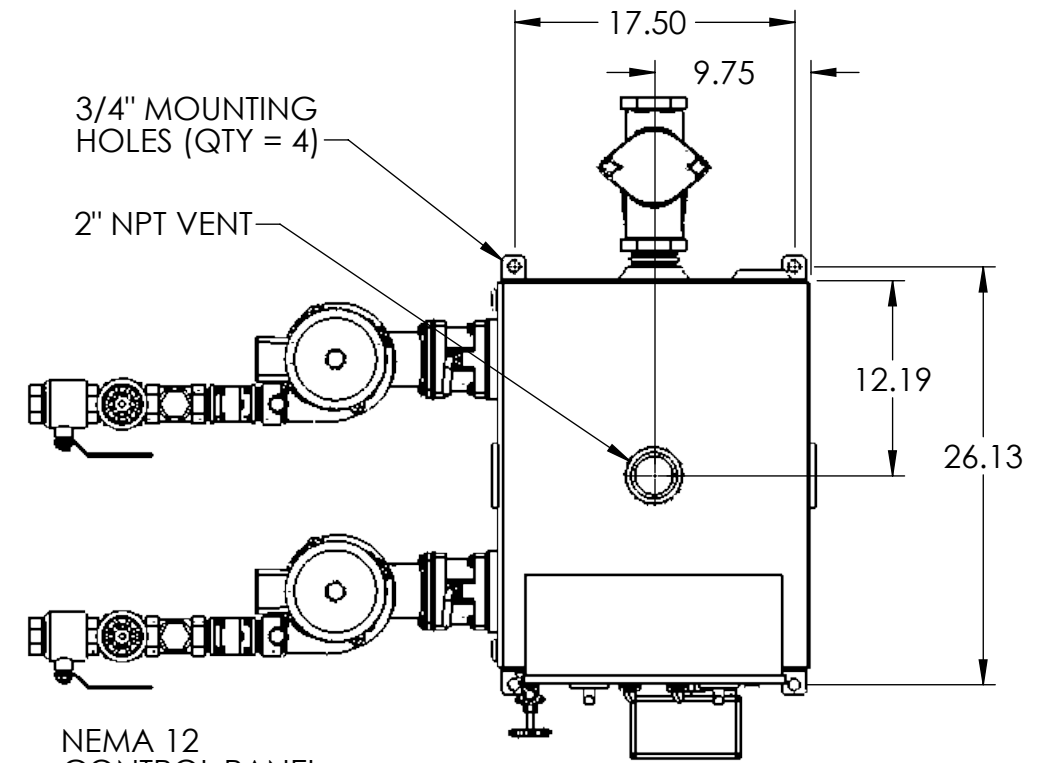
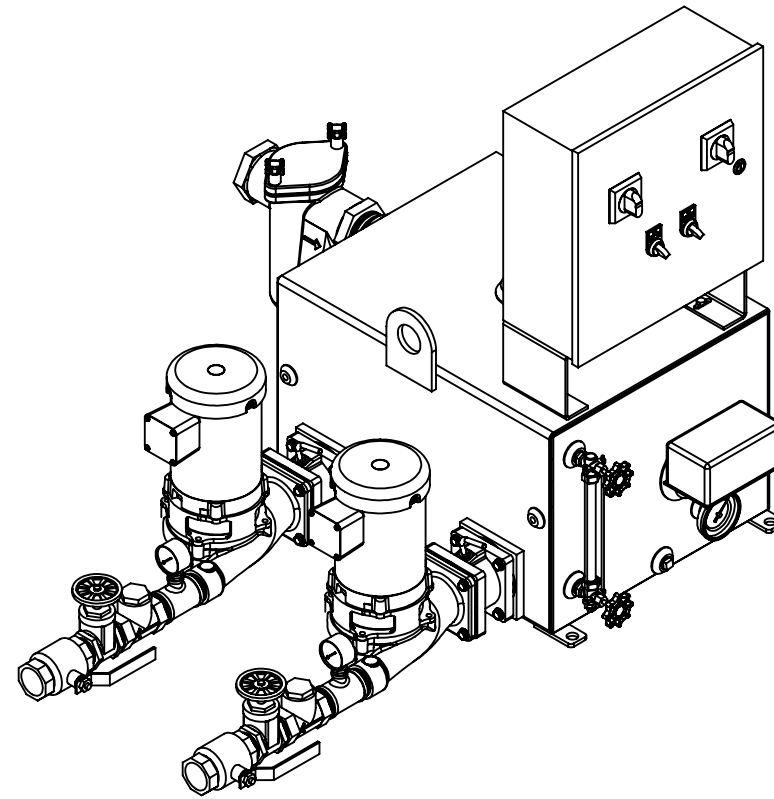

REV	DESCRIPTION	ECN	NAME	DATE
A	Initial Design		GJM	10/31/2017
PART NO: 684.46030.00		NAME	DATE	
DRAWN		GJM	10/31/2017	
CHECKED				
ENG APPR.				
PRODUCT FAMILY		HTSP Boiler and Condensate		
PRODUCT CATEGORY				
TOLERANCES:		THIRD ANGLE PROJECTION		
ANGULAR DIMENSIONS ±1°		TITLE		
FRACTIONS ±1/32		30 GALLON DUPLEX		
TWO PLACE DECIMAL ±0.06		4600 SERIES		
THREE PLACE DECIMAL ±0.030		"K" CONDENSATE PUMP		
SHEET: 1 OF 1	WEIGHT	DRAWING MAY NOT BE PRINTED TO SCALE.	DWG NO.	REV
	2302.51	SCALE: 1:12	684.46030.00	A