



SH-2000 Bimetallic Steam Traps

All Stainless Steel

For pressures to 400 psig (28 bar)...Cold Water Capacities to 4800 lb/hr (2175 kg/hr)

Steam Trapping and Steam Tracing Equipment

Description

SH Series Superheat Steam Traps operate by the effect that rising temperature has on the thermostatic bimetallic elements.

The effect of rising temperature on bimetallic elements operates the Armstrong SH-2000 bimetallic steam trap. It adjusts to changing conditions because the curving of the bimetallic elements, caused by increasing temperature, compensates for increasing pressure.

At start-up, the valve is wide open, which allows a large volume of non-condensables and cold condensate to be removed from the system. When the system reaches steam temperature, the elements become sufficiently hot to pull on the trap's valve stem, closing the valve.

The valve remains closed until the bimetallic elements cool, thus allowing the valve to crack open, venting the condensate and non-condensables, and then close again when steam temperature is reached.

The Armstrong SH-2000 has a sealed, stainless steel body that is lightweight, compact and highly resistant to corrosion. It is adaptable to an Armstrong 360° Universal Connector or a Trap Valve Station (TVS). This makes it easy to install and replace, as the trap can be removed while the connector remains in-line. That means savings in labor cost and ultimate flexibility—because inverted bucket, thermostatic, thermostatic wafer, disc, and float and thermostatic steam traps can all be installed on the same connector.



Maximum Operating Conditions

Maximum allowable pressure (vessel design):
400 psi @ 800°F (28 bar @ 427°C)

Maximum operating pressure: 400 psi (28 bar)

Materials

| | |
|------------------------|-------------------------------------|
| Body: | Stainless Steel |
| Valve & Seat Elements: | Titanium, Ni-Cr and Stainless Steel |
| Ring: | Stainless Steel |
| Cap Assembly: | Stainless Steel |
| Flange: | ASTM A105 Zinc plated |
| Retainer Ring: | Carbon Steel |
| Spiral Wound Gasket: | Stainless Steel |
| Label: | Aluminum |

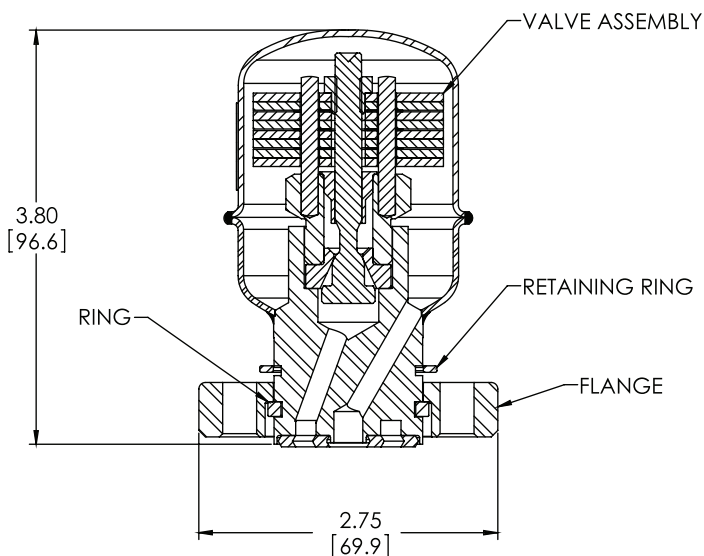

SH-2000 Cold Water Capacity

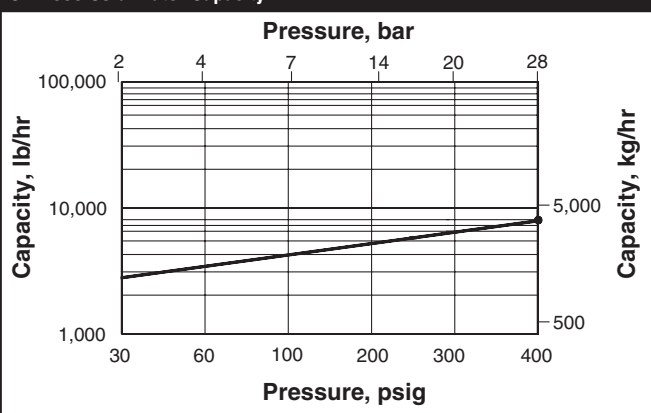

Designs, materials, weights and performance ratings are approximate and subject to change without notice. Visit armstronginternational.com for up-to-date information.