



# Hot Water Generation - Steam to Water

## ReadiTemp® Model RT1020050G and Model RT1020050R

ReadiTemp® is a complete pre-piped water heater with an instantaneous shell and tube heat exchanger design and Emech® Digital Control Valve (E50WR). RT1020050G is designed for non-recirculated systems. RT1020050R is designed for recirculated systems. Emech® uses ceramic disc technology to provide optimized temperature control even in applications with a high pressure differential. Emech® delivers superior performance closed-loop performance in terms of speed, precise temperature control, and longevity. Even with sudden changes of inlet pressure and temperature to the valve, the actuator controller aggressively minimizes outlet temperature variations, making the system ideal for use in process applications.

### Operational Specifications

- Operating Temperature Range: - 13°F to 257°F (-25°C to 125°C)
- $\pm 2^\circ\text{F}$  ( $\pm 1^\circ\text{C}$ ) over a 32°F to 212°F control range (0°C to 100°C range)
- Capable of positioning from 0% to 100% of either inlet supply
- 90° stroke time as low as 1.5 seconds for fast control action
- 100% duty cycle rated actuator
- Capable of control blending to within 1°F of either hot or cold inlet water temperature

### Technical Specifications

- Maximum Domestic Inlet Water Pressure: 145 PSI
- Maximum Inlet Steam Pressure: 15 PSIG
- Minimum Flow Rate: 23 GPM
- Design conditions: At 100°F temperature rise, 200 GPM using 15 PSIG steam at 10,597 lbs/hr
- Single wall heat exchanger tubes shall be straight 5/8" x .065" OD admiralty brass expanded into naval brass tube sheets with a free-floating end cover
- BUBBLE TIGHT zero seat leakage shut-off (exceeds ASME B16.104 and FCI 70.2, Classes V and VI Standards)
- Design verification to ASME B16.34
- Power: 120-240 VAC
- Fail safe position feedback (non-contact absolute encoder)
- Keypad: 4 membrane switches with "dual touch" safety features
- Display: 3.5 digital LCD display with back light
- Gearbox: Planetary, lifetime lubrication, low backlash

### Standard Materials of Construction

- Water Pipe: Stainless steel
- Fittings: Stainless steel
- Single Wall Tube Bundle: Admiralty brass
- Heat Exchanger Shell: Carbon steel
- Steam Trap: Cast iron
- Air Vent: Brass
- Pressure Relief Valve: Stainless steel
- Digital Control Valve: Stainless steel
- Digital Control Valve Discs: Ceramic, durable corrosion resistant
- Frame: Fabricated stainless steel

### Connectivity

- Analog (4-20mA) input and output control signals for interfacing with SCADA control
- External RS232 connection for actuator configuration
- Stand-alone closed loop temperature control or remote analog (4-20mA) control options
- Extra digital input for interfacing ancillary devices (e.g., flow switch, level switch)

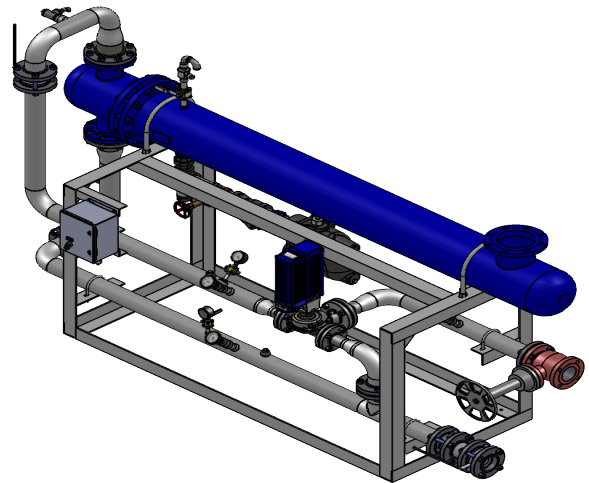

RT1020050G

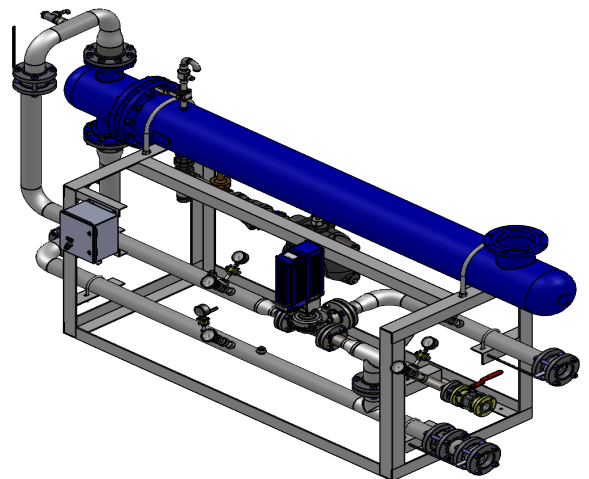

RT1020050R

Designs, materials, weights and performance ratings are approximate and subject to change without notice. Visit [armstronginternational.com](http://armstronginternational.com) for up-to-date information.