



Emech® Model E50S Steam/Water Mixer

The shear action disc design of the E50S valve provides precise controlled mixing of steam and water. Fitted with the electronic actuator and an integrated temperature sensor, the system ensures fast, accurate and stable temperature control. The single compact assembly simplifies installation. The independence of this standalone unit provides a reliable solution for hot water supply for industrial applications.

The calibrated temperature probe fits into a 1/8" NPSM port in the outlet, and connects via a cable to the actuator. With this temperature feedback signal, the actuator can provide temperature control accuracy of $\pm 1^\circ\text{F}$ ($\pm 0.5^\circ\text{C}$) and up to 200°F (95°C) heated water at the outlet.

The E50S can handle a variety of input temperatures and pressures to give a temperature rise. With sudden changes of inlet pressure and temperature to the valve,

Valve Features

- ISO 5211, 5210 actuator flange mounting
- Nickel chrome and cobalt coated CF8M (316) stainless steel discs
- 2" valve flow coefficient Cv(max): 26.6
- Valve constructed of CF8M (316) stainless steel
- End connection: 2" NPT inlets and 2-1/2" NPT outlet
- Top entry allows inline access to internal valve parts
- Maximum allowable pressure: 145 psig @ 482°F
- Maximum operating pressure: 145 psig @ 363°F
- Seat leakage is approximately 0.05% of the valves Cv(max)
- Design verification to ASME B16.34
- U.S. patent approved

Electronic Actuator Features

- Analog (4-20mA) input and output control signals for interfacing with SCADA control
- Software configurable control settings
- Very high resolution capability (0.03° rotational)
- External RS232 connection (cable supplied)
- Stand-alone closed loop temperature control, or remote analog (4-20mA) control options
- Power: regulated 24Vdc 5 Amp supply required
- Fail-safe position feedback (non-contact absolute encoder)
- Keypad: 4 membrane switches with "dual touch" safety features
- Display: 3.5 digit LCD display with back light
- Push-button power switch
- Extra analog input for interfacing ancillary devices (e.g., flow switch, level switch)
- 90° stroke time as low as 1.5 seconds for fast control action
- Gearbox: planetary, lifetime lubrication, low backlash
- 100% duty cycle rated actuator

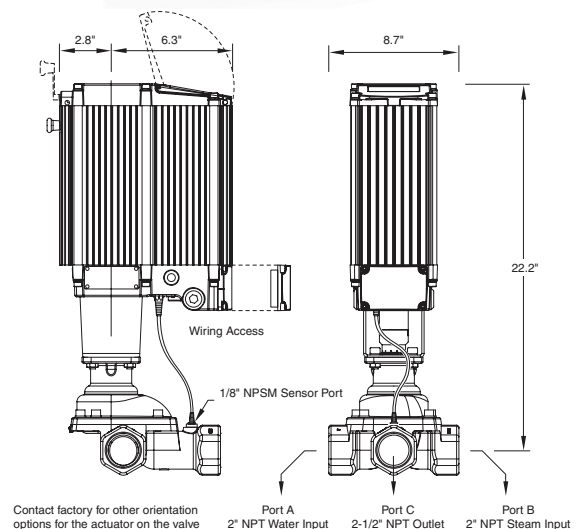
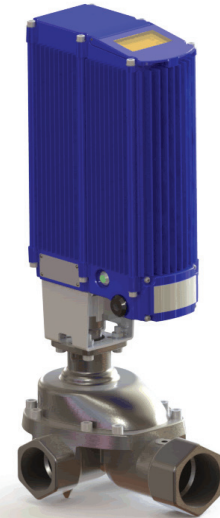

Emech Model E50S Steam/Water Mixer	
Shipping weight	79 lbs (incl packaging)
Shipping box size	13.4" x 30.0" x 13.8" (W x L x H)

IMPORTANT NOTES:

1. A minimum flow rate must be established for effective mixing and temperature control. The approximate minimum flow for effective steam and water mixing for the E50S valve is 20 U.S. gpm.
2. Check (nonreturn) valves MUST be fitted to both inlets. Strainers are also recommended.
3. Sensible pipeline velocities must be considered in application design.
4. Further information on installation requirements and recommendations is available in the "Installation, Operation and Maintenance" Manual (IOM), a copy of which is provided with the product.
5. Armstrong's Engineering Team is available to assist you with application support, component selection and E50S valve sizing.

Safety

Consideration should be given during the design phase to the following conditions of the proposed circuit/system:

- Sudden loss of water pressure
- Loss of power supply
- Over-temperature safety—fail-safe system

If cold water supply or temp. sensor fails, the valve will be closed within approximately 2 seconds.

If there is a loss of power, the unit will remain in its last powered up position and can be manually actuated using the manual override handle.

Designs, materials, weights and performance ratings are approximate and subject to change without notice. Visit armstronginternational.com for up-to-date information.