



Armstrong™ Emech™ Model E50F Flow Control Valve

The Emech port valve utilizes ceramic shear action disc technology to provide tight shut-off, high pressure differential capability and long life integrity.

When combined with the Emech electric actuator and Emech sensor, high speed stand along closed loop temperature control of applications can be achieved. The Emech 2 port valve utilizes ceramic shear action discs as the dynamic seal.

The extremely hard nature of ceramic produces outstanding resistance to wear and cavitation damage compared with conventional elastomer and plastic seated valves, minimizing seal replacement and plant downtime.

Valve Features

- 1/4 Turn action
- ISO 5211, 5210 actuator flange mounting
- Valve constructed of CF8M (316) stainless steel
- Ceramic discs - durable, corrosion resistant
- End connections: NPT, BSPP, ASME Cl. 150 Flanges, Socket Weld, Sanitary Styled Flanges
- Elastomer seal options
- Top entry allows access to internal valve parts
- Body temperature range: -13°F to 257°F
- Rated pressure: 145 psi (10 bar)
- Maximum dynamic pressure drop of 130 psi (9 bar)
- Bubble tight (zero leakage) shut-off
- Manual handle option lock-able in both open and closed position
- Liquid and gas capable
- Seat seal performs beyond the requirements of ANSI B16.104 and FCI 70-2, Classes V and VI

Electronic Actuator Features

- Analog (4-20mA)
- Speed, position, and acceleration control
- User defined '2-speed' stroke can eliminate water hammer
- Very high resolution capability (0.03° rotational)
- Local closed loop control of Temperature
- External RS232 connection (cable supplied)
- Local/remote control options
- Failsafe position feedback (non-contact absolute encoder)
- 4 membrane switches with 'dual touch' safety feature
- 3.5 digit LCD display with back light display
- Push button power switch
- 24Vdc 5 Amp power supply

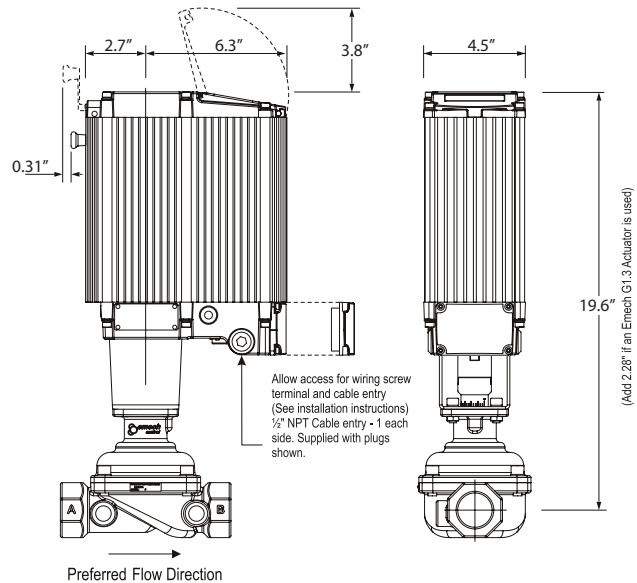

Emech Model E50F Flow Control Valve	
Shipping weight	75 lbs (incl packaging)
Shipping box size	13.4" x 30.0" x 13.8" (W x L x H)

Flow Capacity (gpm)		Pressure Drop (psi)										Max. Flow	C _v
Model	Port Connection Sizes (NPT) Inlets x Outlets	5	10	15	20	25	30	35	40	45	50		
E50F	2" x 2"	185	262	321	370	414	454	490	524	555	585	944	82.8

Note 1: Flow capacity based on specific gravity of water (water = 1) and Max Flow calculated on 130 PSI pressure drop.

Note 2: Sensible pipeline velocities are the only limit to the E50F valve flow rate.

Designs, materials, weights and performance ratings are approximate and subject to change without notice. Visit www.armstronginternational.com for up-to-date information.