



Armstrong™ Emech™ Model E40W Hot/Cold Water Mixer

The 3-port mixing valve utilizes ceramic shear action disc technology to provide tight shut-off, high pressure differential capability, and long life integrity. Fitted with the electronic actuator and integrated temperature sensor, the system delivers high performance stand-alone closed-loop temperature control.

With the temperature feedback signal, the actuator provides temperature control accuracy to $\pm 1^\circ\text{F}$ ($\pm 0.5^\circ\text{C}$) over a 32°F - 212°F (0°C - 100°C) control range, capable of blending from 0% to 100% of either inlet temperature. Even with sudden changes of inlet pressure and temperature to the valve, the actuator controller aggressively minimizes outlet temperature variations, making the system ideal for use in industrial applications as a simple stand-alone or integrated mixing solution.

Valve Features

- ISO 5211, 5210 actuator flange mounting
- Ceramic discs: durable, corrosion resistant
- 1-1/2" valve flow coefficient (Cv): 19.6 mixing; 14.5 single port
- Valve constructed of C8FM (316) stainless steel
- End connection: 1-1/2" NPT inlets and 1-1/2" NPT outlet
- Elastomer seal material options are available to support NON water temperature control applications, e.g., glycol, hydraulic fluid
- Top entry allows inline access to internal valve parts
- Operating temperature range: -13°F to 257°F (-25°C to 125°C)
- Rated pressure: 145 psi (10 bar)
- BUBBLE TIGHT zero seat leakage shut-off (exceeds ASME B16.104 and FCI 70.2, Classes V and VI standards)
- Design verification to ASME B16.34
- U.S. patent approved

Electronic Actuator Features

- Analog (4-20mA) input and output control signals for interfacing with SCADA control
- Software configurable control settings
- Very high resolution capability (0.03° rotational)
- External RS232 connection (cable supplied)
- Stand-alone closed loop temperature control, or remote analog (4-20mA) control options
- Power: regulated 24Vdc 3.5Amp supply required
- Failsafe position feedback (non-contact absolute encoder)
- Keypad: 4 membrane switches with "dual touch" safety features
- Display: 3.5 digit LCD display with back light
- Push-button power switch
- Extra analog input for interfacing ancillary devices (e.g., flow switch, level switch)
- 90° stroke time as low as 1.5 seconds for fast control action
- Gearbox: planetary, lifetime lubrication, low backlash
- 100% duty cycle rated actuator

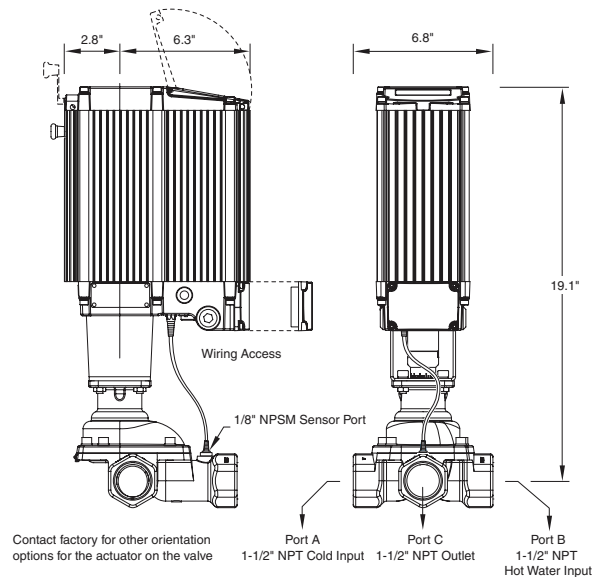
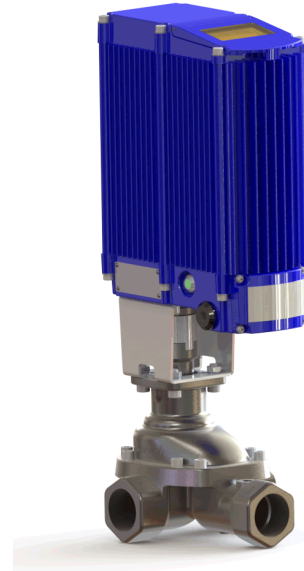

Emech Model E40W Hot/Cold Water Mixer	
Shipping weight	54 lbs (incl packaging)
Shipping box size	12.6" x 23.6" x 12.4" (W x L x H)

IMPORTANT NOTE: Further information on installation requirements and recommendations is available in the "Installation, Operation and Maintenance" Manual (IOM), a copy of which is provided with the product.

Flow Capacity (gpm)														
Model	Port Connection Sizes (NPT) Inlets x Outlets	Pressure Drop (psi)										Nominal Min. Flow (Note 4)	Max. Flow	C _v
		5	10	15	20	25	30	35	40	45	50			
E40W	1-1/2" x 1-1/2"	44	62	76	88	98	108	116	124	132	139	6.0	Note 2	19.6

NOTE 1: Check valves MUST be installed on both inlets to the mixing system.
 NOTE 2: Sensible pipeline velocities are the only limit to the E40W mixing valve flows.
 NOTE 3: Contact Armstrong or visit Web site for Armstrong E40W valve sizing program and Application Notes.

NOTE 4: The nominal recommended Min. Flow is described as:
 • The minimum flow at which temperature control can be readily achieved for the given valve size with the Actuator set at STANDARD control gain setting.
 • Contact the factory for applications where flow conditions are lower than those stated above.

Designs, materials, weights and performance ratings are approximate and subject to change without notice. Visit www.armstronginternational.com for up-to-date information.