



Water Temperature Control - Recirculation Systems

Digital

The Brain® Model DRV50

DRV50 Digital Recirculation Valve (DRV) designed specifically to be the primary water temperature controller in a continuously pumped circulating hot water system.

Digital technology provides enhanced water temperature control accuracy which resists zero system demand “Temperature Creep” without the use of a manual throttling valve or a temperature activated pump shut-off device (aquastat).

Operational Specifications

- +/-2°F DRV water temperature control at peak, moderate or zero fixture demand on hot water system designed for continuous recirculation
- 1°F minimum recirculating water temperature differential
- LCD display which indicates: set point, delivered temperature, error codes and alarm conditions capable of BAS and mobile connectivity
- Programmable set point range of 81-158°F (27-70°C) capable of BAS or mobile monitoring and adjustment
- Programmable thermal disinfection range of 158-185°F (70-85°C)
- Programmable 1st level hi/lo temp alarm display capable of BAS or mobile alerting
- Automatic safe closure of hot water inlet in response to: inlet supply failure, 110V power failure, or programmable high temperature error
- Automatic safe closure of hot water inlet powered by a replaceable lithium battery monitored for low-level alerting

Technical Specifications

- 100-240V AC
- Polymer Electronics Enclosure
- Stainless Steel Valve Construction
- Lead Free compliant
- Maximum inlet HW supply temperature 185°F (85°C)
- Minimum Continuous Recirculation - 10 GPM (38 LPM)
- Minimum System Draw Off - 0 GPM
- Conforms to ASSE 1017, CSA B125.3-11, UL E357437, and CE
- Operational water pressure of 10-200 psig (7-13.3 barg)
- Display in °C or °F
- Shipping weight 23 lbs (10 kg)
- Integral MODBUS RTU for direct connectivity to BAS, or SAGE®

Connectivity

RS485 Serial Port – Integral MODBUS RTU for direct connectivity to BAS. Seamless integration with SAGE® (BS) connectivity options.

See DRV50BS for SAGE® (BS) module available with specific ProtoCessor cards for BAS Connectivity to systems which operate on Modbus TCP, BACnet™, or LonWorks™ protocols. Mobile Connectivity may be enabled by a customer activated no-term subscription.

Mobile Connectivity features smart hot water system dashboard monitoring, secure remote programming, multi-location view, temperature and system diagnostic alerts, with unlimited digital documentation and automated report generation.

For a submittal drawing, refer to D40864.

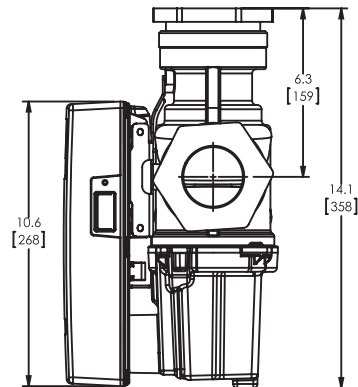
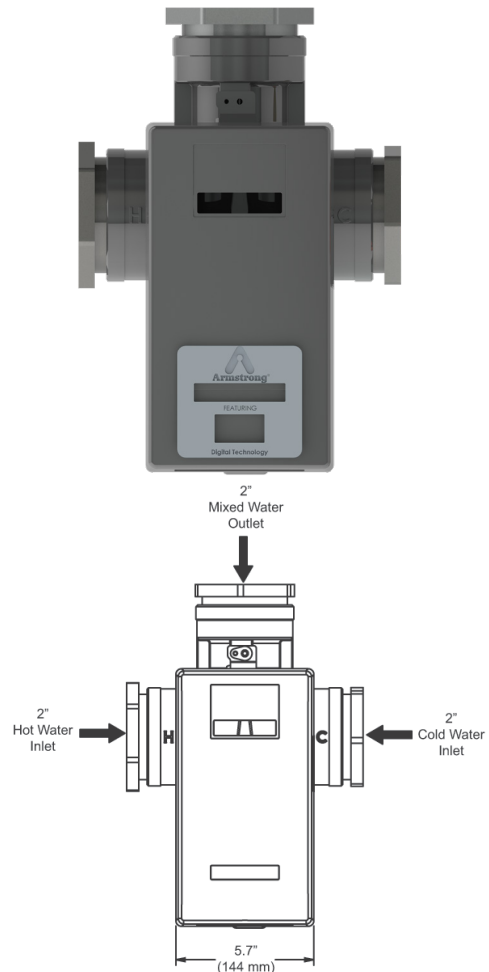

Recirculation Systems - Digital (GPM and PSIG)						
Model	Pressure Drop (PSIG)				Minimum System Draw-Off	C _v
	5	10	15	20		
DRV50						
GPM	94	133	163	188	0	42

Recirculation Systems - Digital (LPM and BARG)						
Model	Pressure Drop (BARG)				Minimum System Draw-Off	C _v
	0.3	0.7	1.0	1.4		
DRV50						
LPM	355.8	503.5	617.0	711.7	0	42

Designs, materials, weights and performance ratings are approximate and subject to change without notice. Visit armstronginternational.com for up-to-date information.