



Armstrong® Water Temperature Control - Recirculation Systems

Digital

The Brain® Model DMC25 Flex Zone PHE

DMC25 Flex Zone PHE is a fully Digital Mixing Center (DMC) specifically designed to be the primary water temperature controller in a domestic hot water zone with independent continuous recirculation reheat generated by a plate heat exchanger (PHE).

Digital technology provides enhanced water temperature control accuracy which resists zero system demand "Temperature Creep" without the use of a manual throttling valve or a temperature activated pump shut-off device (aquastat).

Completely integral digital valve with no need for external or ancillary components such as actuators, sensors or controllers.

Operational Specifications (DRV25)

- Ready to go out of the box or field adjustable via Bluetooth® connectivity with the SAGE® mobile app
- +/-2°F DRV water temperature control at peak, moderate or zero fixture demand on hot water system designed for continuous recirculation
- 1°F minimum recirculating water temperature differential
- Programmable set point range of 81-158°F (27-70°C) capable of BAS or SAGE® mobile app for monitoring and adjustment
- Programmable thermal disinfection range of 158-185°F (70-85°C)
- Automatic safe closure of hot water inlet in response to: inlet supply failure, 110V power failure, or programmable high temperature error
- Automatic safe closure of hot water inlet powered by a replaceable lithium battery monitored for low-level alerting

Technical Specifications

- 100-240V AC
- Polymer Electronics Enclosure
- Stainless Steel Valve Construction
- Lead Free compliant
- Maximum inlet HW supply temperature 185°F (85°C); 131°F (55°C) during Group Control
- Minimum Continuous Recirculation - 2 GPM (7.6 LPM)
- Minimum System Draw Off - 0 GPM; 2 GPM (7.6 LPM) during Group Control
- Conforms to ASSE 1017, CSA B125.3-11, UL E357437, and CE
- Operational water pressure of 10-150 psig (.7-10.3 barg)
- Bluetooth® (BLE) enabled for direct communication with the DRV25 via the SAGE® mobile app status dashboard and programming.
- Shipping weight 30 lbs (16.8 kg)
- Stainless steel brazed plate double wall PHE (Custom PHE options available)
 - 2 Standard Configurations Available; Customs Available upon Request
 - Standard #1 = PHE-410-18 (see Specification & Submittal Drawing-D133126 for System Parameters)
 - Standard #2 = PHE-410-38 (see Specification & Submittal Drawing-D133128 for System Parameters)

Connectivity

RS485 Serial Port – Integral MODBUS RTU for direct connectivity to BAS. Seamless integration with SAGE® (BS) connectivity options.

SAGE® mobile app allows for Bluetooth® (BLE) communications with the DRV25 and SAGE® to Cloud communications if optional mobile connectivity subscription is activated

See DMC25BS Flex Zone PHE for SAGE® (BS) module available with specific ProtoCessor cards for BAS Connectivity to systems which operate on Modbus TCP, BACnet™, or LonWorks™ protocols. Mobile Connectivity may be enabled by a customer activated no-term subscription.

Mobile Connectivity features smart hot water system dashboard monitoring, secure remote programming, multi-location view, temperature and system diagnostic alerts, with unlimited digital documentation and automated report generation.

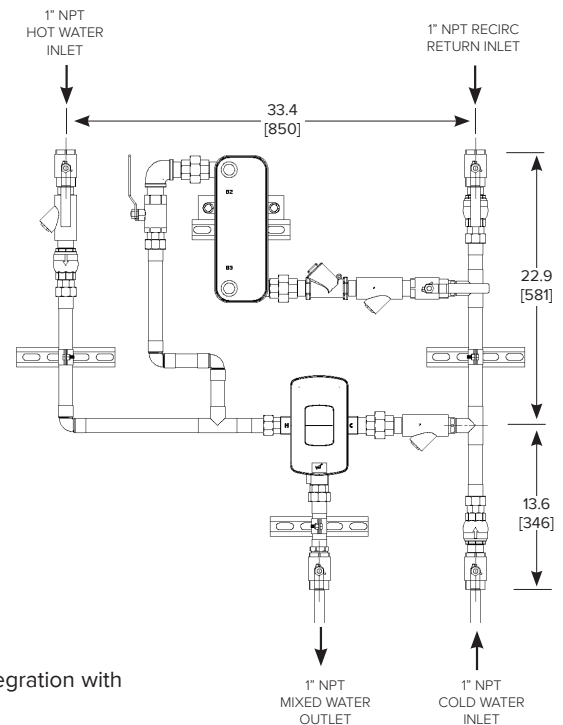
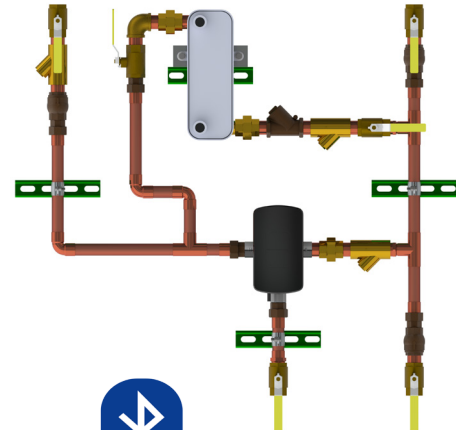

Recirculation Systems - Digital (GPM and PSIG)						
Model	Pressure Drop (PSIG)				Minimum System Draw-Off	C _v
	5	10	15	20		
DMC25 Flex	5	10	15	20	0	9.8
GPM	22	31	39	45		

Recirculation Systems - Digital (LPM and BARG)						
Model	Pressure Drop (BARG)				Minimum System Draw-Off	K _v
	0.3	0.7	1.0	1.4		
DMC25 Flex	0.3	0.7	1.0	1.4	0	8.5
LPM	81	118	145	171		

Designs, materials, weights and performance ratings are approximate and subject to change without notice. Visit armstronginternational.com for up-to-date information.