



Armstrong® STEAMIX® Steam & Water Hose Stations & Mixing Units

Model 2033SSE – Stainless Steel

STEAMIX® Model 2033SSE Steam/Water Mixing Valve of Type 304 stainless steel construction.

STEAMIX® Model 2033SSE is supplied as standard with all stainless steel (SS) integral inlet supply risers comprising 3/4" Y-type strainers and 3/4" ball valves cross-linked by a stainless steel bridge piece and lever for simultaneous on/off control of both inlet supplies. The unit is supplied fully assembled and pressure-tested. Stainless Steel dual scale top mount. Thermometer and Inlet Check Valves Included.

Safety Features

- **STEAMIX® 2033SSE will not pass live steam.** In the event of either a complete failure of the inlet cold-water supply or a reduction in cold water pressure to below 1,4 bar, STEAMIX will respond with a shutdown of outlet flow.
- If there is a structural failure of the primary operating component (diaphragm), STEAMIX will "fail safe" to cold water.
- To prevent over-temperature selection by the user and the potential for overheated water and flash steam presentation common with other types of hose stations, STEAMIX is supplied with a single-temperature locking set.

Technical Specifications

- 3/4" (20 mm) BSPT inlets and 3/4" (20 mm) NPT outlets
- Type 304 stainless steel construction
- Operating pressures:
 - Maximum: 10 bar
 - Minimum: 1,4 bar†
- Maximum pressure loss ration: 10:1**
- Inlet check valves included
- Shipping weight: 18,6 kg

† **IMPORTANT NOTE: Lower steam pressures significantly reduce outlet flow rates.**

** Ratio of inlet pressures accounting for restrictions on valve outlet (minus back pressure).

Flow Rates

The capacity charts indicate expected flow rates at constant steam and water pressure and with an unrestricted open outlet.

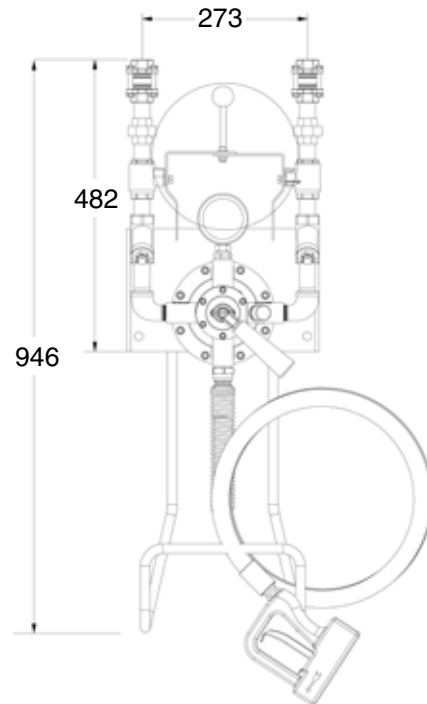

A) 31°C Temperature Rise						
Water	Steam	1,4	3	5	7	bar
	1,5 bar	26,1	38,6	38,6	38,6	l/min
	3 bar	26,1	49,9	49,9	49,9	l/min
	4 bar	26,1	52,2	59,4	59,4	l/min
B) 56°C Temperature Rise						
Water	Steam	1,4	3	5	7	bar
	1,5 bar	13,6	26,1	31,4	32,1	l/min
	3 bar	13,6	26,1	35,5	37,4	l/min
	4 bar	13,6	26,1	35,5	39,7	l/min
C) 75°C Temperature Rise						
Water	Steam	1,4	3	5	7	bar
	1,5 bar	9,4	18,9	24,9	37,2	l/min
	3 bar	9,4	18,9	27,2	30,2	l/min
	4 bar	9,4	18,9	27,2	30,2	l/min

All dimensions and weights are approximate. Use certified print for exact dimensions. Design and materials are subject to change without notice.