



STEAMIX® Steam & Cold Water Hose Stations and Mixing Units

Model 2031SS - Stainless Steel

STEAMIX® Model 203SS Steam/Water Mixing Valve of Type 304 stainless steel construction.

STEAMIX® Model 2031SS is supplied as standard with all stainless steel (SS) integral inlet supply risers comprising 3/4" Y-type strainers and 3/4" ball valves cross-linked by a stainless steel bridge piece and lever for simultaneous on/off control of both inlet supplies. The unit is supplied fully assembled and pressure tested. Stainless Steel dual scale top mount Thermometer and Stainless Steel Inlet Check Valves included.

Safety Features

- **Steamix 203SS will not pass live steam.** In the event of a complete failure of the inlet cold-water supply, or a reduction in cold-water pressure to below 20 (+/-5) psi (1.4 bar), STEAMIX will safely respond with a complete shutdown of outlet flow.
- In the event of an unlikely structural failure of the diaphragm (primary operating component), STEAMIX will "fail safe" to cold water.
- To prevent over-temperature selection by the user and the potential for overheated water and flash steam presentation common with other types of hose stations, STEAMIX is supplied with a single-temperature locking set.

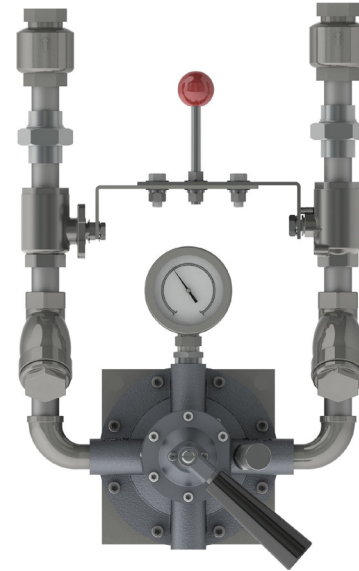

Technical Specifications

- 3/4" (20 mm) NPT inlets/outlet(s)
- Type 304 stainless steel construction
- Operating pressures
 - Maximum: 150 psi (10 bar)
 - Minimum: 20 psi* (1.4 bar)
- Maximum pressure loss ratio 10:1**
- Inlet check valves included
- Weight: 40 lbs (18 kg)

† **IMPORTANT NOTE: Lower steam pressures significantly reduce outlet flow rates.**

† Ratio of inlet pressures accounting for restrictions on valve outlet (minus back pressure).

Flow Rates

The capacity charts indicate STEAMIX 203 flow rates at steam and water pressures commonly available in the average manufacturing plant. The STEAMIX 203 can handle a wide diversity of pressures and temperatures. Three typical outlet temperatures shown in the flow tables were selected to demonstrate the valve's flow rate at:

- A) "User safe" temperature (approx. 120°F - 48°C)
- B) "Hot hose down" temperature (approx. 150/160°F - 65/71°C)
- C) "Common bacteria kill" temperature (approx. 180°F - 82°C)

NOTE: All flow rates shown are with open outlet, and a reduction of flow is to be expected depending on the length and diameter of outlet pipework, washdown hose, spray nozzle, etc.

For a fully detailed approval drawing, refer to D31128.

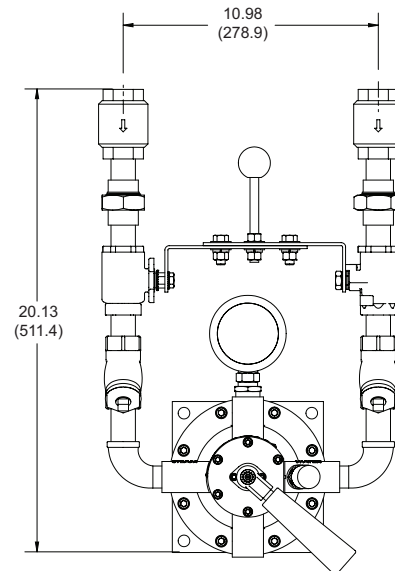

A) 55°F (31°C) Temperature Rise						
Water \ Steam	20 (1.4)	45 (3)	75 (5)	100 (7)	psi (bar)	
22 psi (1.5 bar)	6.9 (26.1)	10.2 (38.6)	10.2 (38.6)	10.2 (38.6)	gal/min (l/min)	
45 psi (3 bar)	6.9 (26.1)	13.2 (49.9)	13.2 (49.9)	13.2 (49.9)	gal/min (l/min)	
60 psi (4 bar)	6.9 (26.1)	13.8 (52.2)	15.7 (59.4)	15.7 (59.4)	gal/min (l/min)	
B) 100°F (56°C) Temperature Rise						
Water \ Steam	20 (1.4)	45 (3)	75 (5)	100 (7)	psi (bar)	
22 psi (1.5 bar)	3.6 (13.6)	6.9 (26.1)	8.3 (31.4)	8.5 (32.1)	gal/min (l/min)	
45 psi (3 bar)	3.6 (13.6)	6.9 (26.1)	9.4 (35.5)	9.9 (37.4)	gal/min (l/min)	
60 psi (4 bar)	3.6 (13.6)	6.9 (26.1)	9.4 (35.5)	10.5 (39.7)	gal/min (l/min)	
C) 135°F (75°C) Temperature Rise						
Water \ Steam	20 (1.4)	45 (3)	75 (5)	100 (7)	psi (bar)	
22 psi (1.5 bar)	2.5 (9.4)	5.0 (18.9)	6.6 (24.9)	7.2 (27.2)	gal/min (l/min)	
45 psi (3 bar)	2.5 (9.4)	5.0 (18.9)	7.2 (27.2)	8.0 (30.2)	gal/min (l/min)	
60 psi (4 bar)	2.5 (9.4)	5.0 (18.9)	7.2 (27.2)	8.0 (30.2)	gal/min (l/min)	