



Emech® Three-Way Temperature Control Valve

Water to Water Mixing - E100WR

Emech® Three-Way Temperature Control Valve

Emech® Three-Way Temperature Control Valve provides temperature control accuracy to $\pm 2^{\circ}\text{F}$ (1°C) over a $32^{\circ}\text{F} - 212^{\circ}\text{F}$ ($0^{\circ}\text{C} - 100^{\circ}\text{C}$) control range, capable of blending from 0% to 100% of either inlet temperature.

The electronic actuator and temperature sensor deliver high-performance, stand-alone, closed-loop control. Emech® utilizes rotary turret control geometry to provide high-performance dynamic fluid mixing.

Even with sudden changes to inlet pressures and temperatures, the actuator aggressively responds to minimize outlet temperature variations, making the system ideal for use in a variety of applications as a simple standalone mixing valve, or as an integrated mixing solution.

General Features

- Any two ports can be configured as inlet ports
- Non-water applications supported (e.g. glycol, hydraulic fluid)
- Top entry to valve allows inline access to internal parts
- 90° stroke time as low as 1.5 seconds for fast control action
- Precise positioning achieving 0.03° valve seat placement
- Keypad display for full actuator configuration without external devices required
- Local closed-loop temperature control
- Failsafe position feedback (non-contact absolute encoder)
- Manual override with electrical safety interlock
- 100% duty cycle rated for continuous control
- Electronic stroke setting (up to 355° rotation)

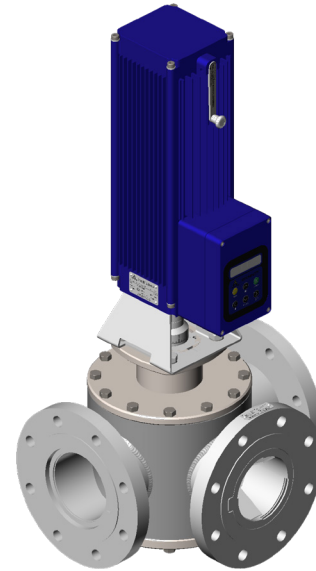

E100WR

Material and Design Specifications	
Valve Body	Stainless Steel CF8M (Type 316)
Internal Components	
Seal Material	Elastomer
Actuator Mounting	ISO 5211, 5210
End Connection	4" ASME 816.5 Class 150 Flange
Enclosure	NEMA 4X

Technical Specifications	
Operating Temperature	-13° - 257°F (-25°C - 125°C)
Operating Pressure	232 psi (16 bar)
Leakage Class	Class IV FCI 70-2-1998 (< 0.01% capacity)
Design	ASME B16.34
Operating Mode	<ul style="list-style-type: none"> • Standalone control via onboard keypad • Analog (4-20mA input and output) • Modbus (RS-485 port)

Flow Capacity - gpm (lpm)													
Model	Port Connection Sizes Inlets x Outlets	Pressure Drop - psi (bar)										Nominal Min. Flow* gpm (lpm)	C _v (K _v)
		5 (0.3)	10 (0.7)	15 (1.0)	20 (1.4)	25 (1.7)	30 (2.1)	35 (2.4)	40 (2.8)	45 (3.1)	50 (3.4)		
E100WR	4" x 4" ASME B16.5 Class 150 Flanges	736 (2,785)	1,040 (3,938)	1,274 (4,823)	1,471 (5,570)	1,645 (6,227)	1,802 (6,821)	1,946 (7,368)	2,081 (7,877)	2,207 (8,354)	2,326 (8,806)	160.0 (605.7)	329.0 (284.3)

*The nominal recommended minimum flow is described as the minimum flow at which temperature control can be readily achieved for the given valve size with the actuator set at a STANDARD control gain setting. Contact the factory for applications where flow conditions are lower than those stated above.

See FLOW CAPACITIES note at the end of this document.

Designs, materials, weights and performance ratings are approximate and subject to change without notice. Visit armstronginternational.com for up-to-date information.



Emech® Three-Way Temperature Control Valve

Water to Water Mixing - E100WR

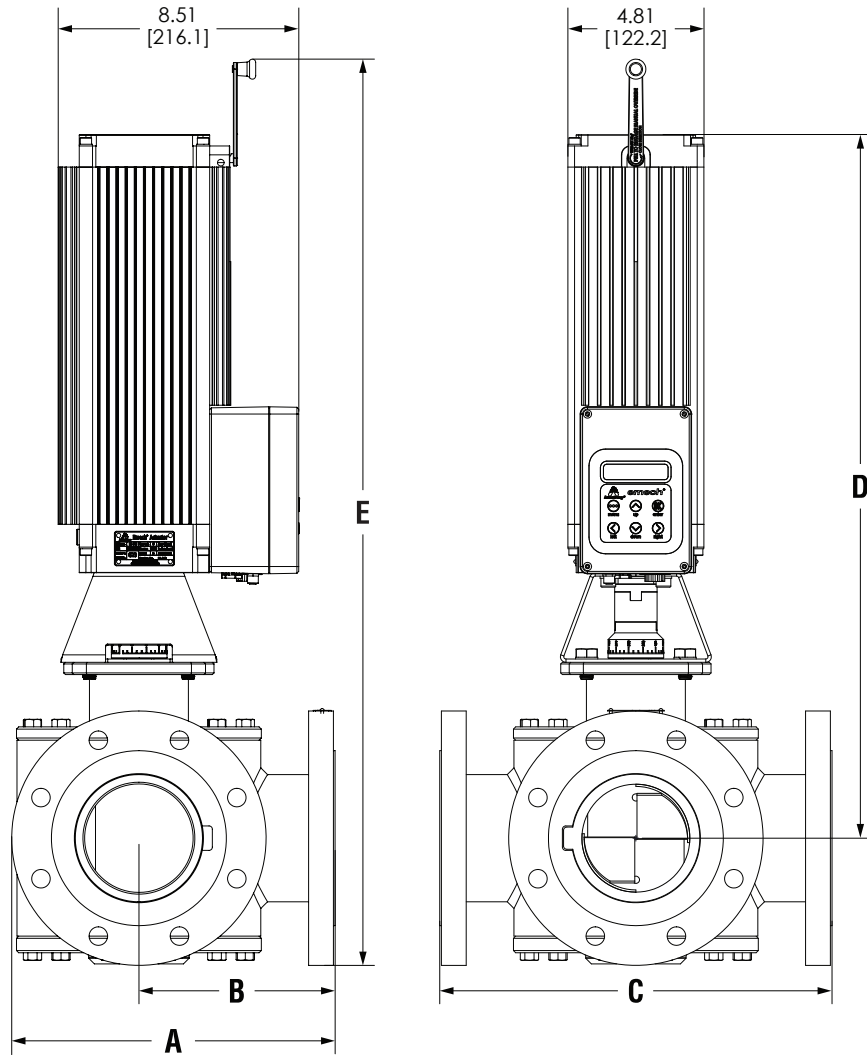

Dimensions - Flanged E100WR

Dimensions					
Model	A	B	C	D	E
	in (mm)	in (mm)	in (mm)	in (mm)	in (mm)
E100WR	11.38 (289.1)	6.94 (176.3)	13.76 (349.6)	24.88 (632.0)	32.06 (814.3)

Shipping Weights and Shipping Box Size					
Model	Length	Width	Height	Product Weight	Ship Weight
	in (mm)	in (mm)	in (mm)	lbs (kg)	lbs (kg)
E100WR	32.75 (831.9)	16.00 (406.4)	20.00 (508.0)	173 (78.5)	202 (91.6)

IMPORTANT NOTES:

- Check valves **MUST** be installed on both inlets to the mixing system.
- Contact Armstrong or visit armstronginternational.com for Emech® valve sizing program and application notes.
- NTC temperature probe assembly must be fitted into pipework 15.75" (400mm) downstream of the outlet port (fits into 1/2" NPT female thread).
- Ensure that straight pipes to the valve are as long as possible. Elbows prior to the inlet should be long 'sweep style' and no closer than 6 pipe diameters from the inlet.

FLOW CAPACITIES:

- Sensible pipeline velocities are the only limit to the Emech® Water to Water mixing valve flows.

Further information on installation requirements and recommendations are available in the G2 Manual (IOM-458).

Designs, materials, weights and performance ratings are approximate and subject to change without notice. Visit armstronginternational.com for up-to-date information.