

APPROVAL

BY: _____ DATE: _____

- APPROVED, PROCEED WITH FABRICATION
- APPROVED AS NOTED, PROCEED WITH FABRICATION IN ACCORDANCE WITH COMMENTS
- DISAPPROVED, DO NOT FABRICATE

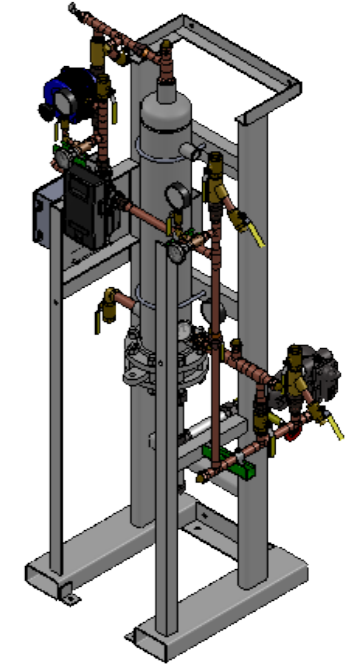

**DIGITAL FLO SEMI INSTANTANEOUS
DOUBLE WALL**

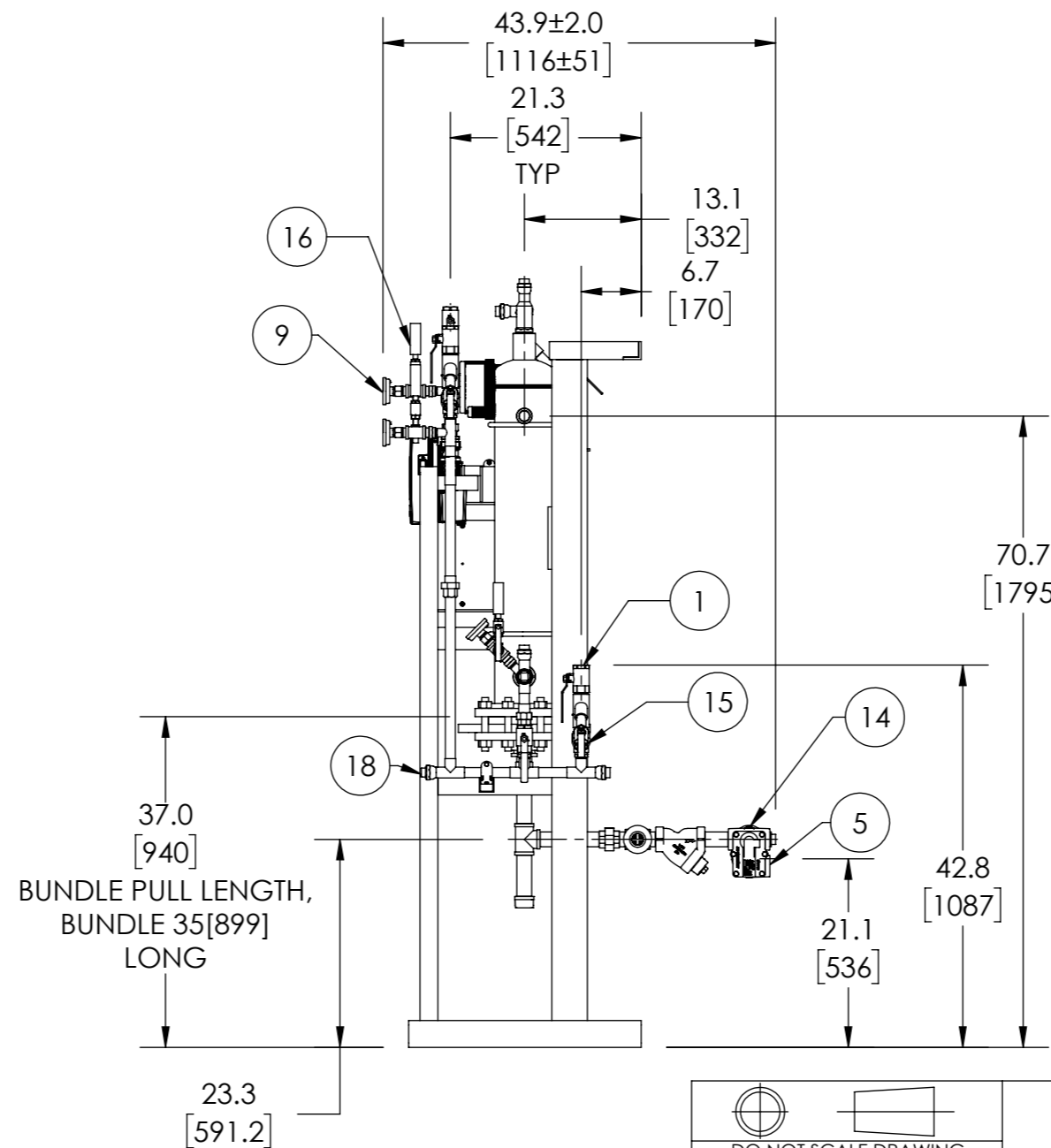
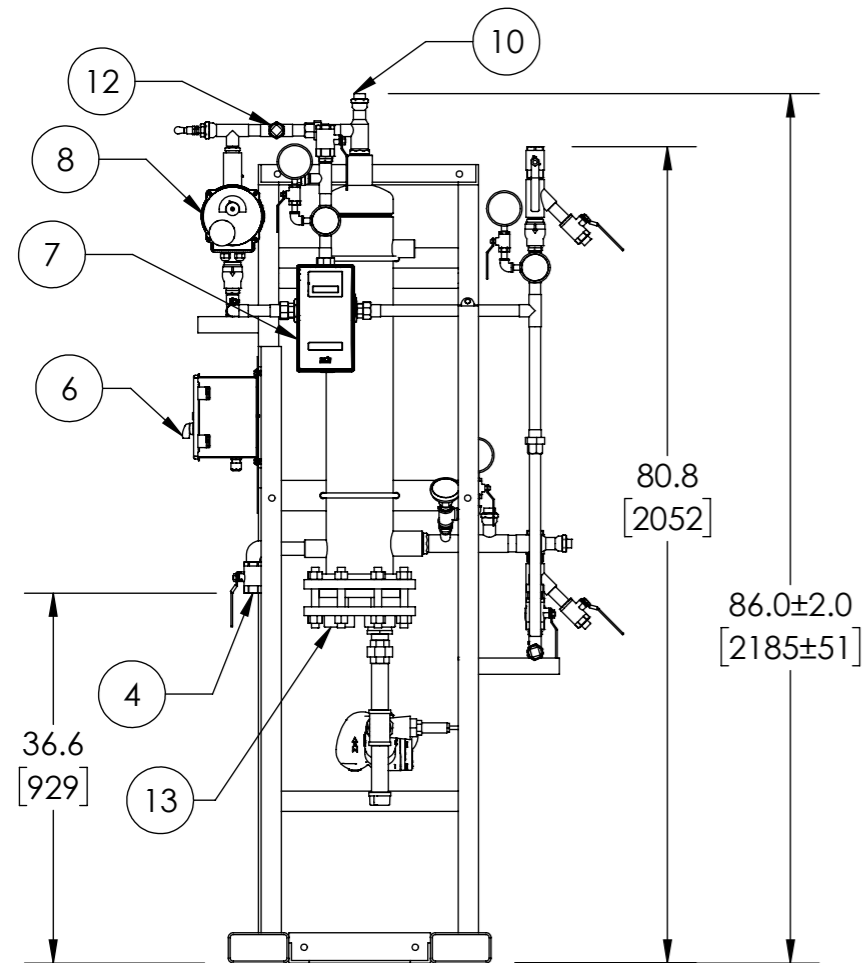
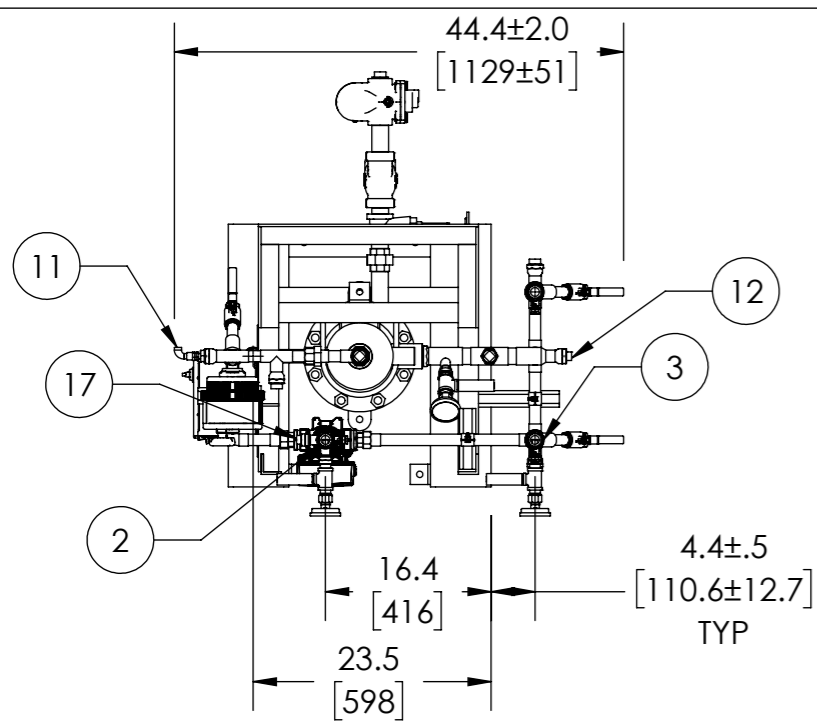

ITEM	DESCRIPTION	CONNECTION
1	COLD WATER INLET	1" NPT
2	MIXED WATER OUTLET	1" NPT
3	RECIRC WATER INLET	1" NPT
4	DRAIN	1" NPT
5	CONDENSATE OUTLET	1-1/4" NPT
6	ELECTRICAL PANEL	110VAC @1.2A
7	DRV40	1-1/2" NPT
8	N.C. ACTUATED BALL VALVE SAFETY SHUT OFF	1" NPT
9	THERMOMETER (3)	1/2" NPT
10	SRV CONNECTION (PRESSURE ONLY; USER SUPPLIED)	1" NPT
11	SRV (PRESSURE) PIPE TO DRAIN	1/4" NPT
12	CIP CONNECTION(2)	1" NPT
13	STEAM INLET	2" NPT
14	VACUUM BREAKER	1/2" NPT
15	BLOW DOWN(3)	3/4" NPT
16	PRESSURE GAUGE (3)	1/4" NPT
17	SRV (CONNECTION FOR USER SUPPLIED T&P)	3/4" NPT
18	DRAIN OR EXPANSION TANK CONNECTION	1" NPT
ITEM	MATERIAL	
	PIPING	COPPER TYPE "L"
	EXCHANGER SHELL MATL.	DUPLEX 2205 SS
	EXCHANGER TUBING MATL.	COPPER
	INSULATION JACKET	REMOVEABLE JACKET

DO NOT SCALE DRAWING TOLERANCES UNLESS OTHERWISE SPECIFIED		
DIMENSIONING ENGLISH [mm]		
FRACTIONAL ± 1/64 ANGULAR: ± 2		
DECIMAL	.XXX ± .0005	.010
	.XX ± .015	.10
	.X ± .3	.3

NAME	DATE
CFG	5/18/2015
RELEASED	

ARMSTRONG INTERNATIONAL
Copyright © 2010 ARMSTRONG INTERNATIONAL, INC.

DFS15DW40BS

MATERIAL	SHEET 1 OF 1
REV A	SALES

- NOTE(S):
- ALL DIMENSIONS +/-0.5 [13] UNLESS OTHERWISE SHOWN.
 - COMPLETE ASSEMBLY LEAD FREE COMPLIANT - THE WETTED SURFACE OF THIS PRODUCT CONTACTED BY CONSUMABLE WATER CONTAINS LESS THAN ONE QUARTER OF ONE PERCENT (0.25%) OF LEAD BY WEIGHT.
 - PACKAGE INCLUDES ALL REQUIRED INLET CHECK VALVES AND STRAINERS ON DOMESTIC SIDE.
 - DRV, SAFETY SHUT OFF AND ELECTRICAL PANEL ARE PREWIRED TO PROVIDE A SINGLE ELECTRICAL LANDING POINT AT THE PANEL.