

APPROVAL

- BY: _____ DATE: _____
- APPROVED, PROCEED WITH FABRICATION
 - APPROVED AS NOTED, PROCEED WITH FABRICATION IN ACCORDANCE WITH COMMENTS
 - DISAPPROVED, DO NOT FABRICATE

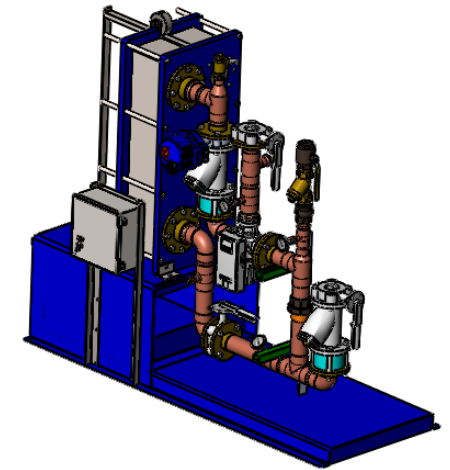

DIGITAL FLO BOILER WATER/WATER PLATE & FRAME HEAT EXCHANGER SINGLE WALL

PIPING AND COMPONENTS HIDDEN TO SHOW CONNECTIONS

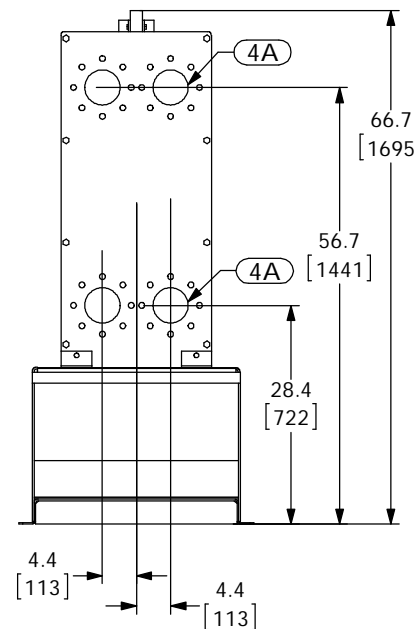

PROJECT NAME :

TAG :

ITEM	DESCRIPTION	CONNECTION
1	COLD WATER INLET	3" FLG ANSI 150
2	MIXED WATER OUTLET	3" FLG ANSI 150
3	RECIRC WATER INLET	2" NPT
4A	PRIMARY(BOILER) INLET	4" FLG ANSI 150
4B	PRIMARY(BOILER) OUTLET	4" FLG ANSI 150
5	ELECTRICAL PANEL/BRAINSCAN	110VAC @ 1.2A
6	DRV80	3" NPT
7	N.C. ACTUATED BALL VALVE SAFETY SHUT OFF	3" WAFER
8	THERMOMETER (3)	
9	CIP CONNECTION (2)	1-1/2" AND 1" NPT
10	SRV(PRESSURE) PIPE TO DRAIN	1" NPT
11	SRV(CONNECTION FOR USER SUPPLIED T&P)	1-1/2" NPT
ITEM	MATERIAL	
PIPING	COPPER TYPE "L"	
EXCHANGER PLATE MATL.	T316L SS	
EXCHANGER GASKET MATL.	NITRILE	

NOTE(S):

- ALL DIMENSIONS +/- .5[13] UNLESS OTHERWISE SHOWN.
- COMPLETE ASSEMBLY LEAD FREE COMPLIANT - THE WETTED SURFACE OF THIS PRODUCT CONTACTED BY CONSUMABLE WATER CONTAINS LESS THAN ONE QUARTER OF ONE PERCENT (0.25%) OF LEAD BY WEIGHT.
- PACKAGE INCLUDES ALL REQUIRED INLET CHECK VALVES AND STRAINERS ON DOMESTIC SIDE.
- DRV, SAFETY SHUT OFF AND ELECTRICAL PANEL ARE PREWIRED TO PROVIDE A SINGLE ELECTRICAL LANDING POINT AT THE PANEL.

DO NOT SCALE DRAWING	
TOLERANCES UNLESS OTHERWISE SPECIFIED	
DIMENSIONING ENGLISH [mm]	
FRACTIONAL	± 1/64
ANGULAR	± 2
DECIMAL	XXX ± .0005
	XXX ± .005
	XX ± .015
	X ± .3

NAME: _____ DATE: _____

DRAWN: CFG 02/26/2013

RELEASED: SALES

ARMSTRONG INTERNATIONAL
Copyright © 2010 ARMSTRONG INTERNATIONAL, INC.

DF90W80BS 3 FLG 3 FLG 2 NPT
CPR

CONFIG# (C-XXXXXX)

MATERIAL: _____ SHEET 1 OF 1

REV: _____ DWG: D5XXXXX