

APPROVAL

BY: _____ DATE: _____

- APPROVED, PROCEED WITH FABRICATION
- APPROVED AS NOTED, PROCEED WITH FABRICATION IN ACCORDANCE WITH COMMENTS
- DISAPPROVED, DO NOT FABRICATE

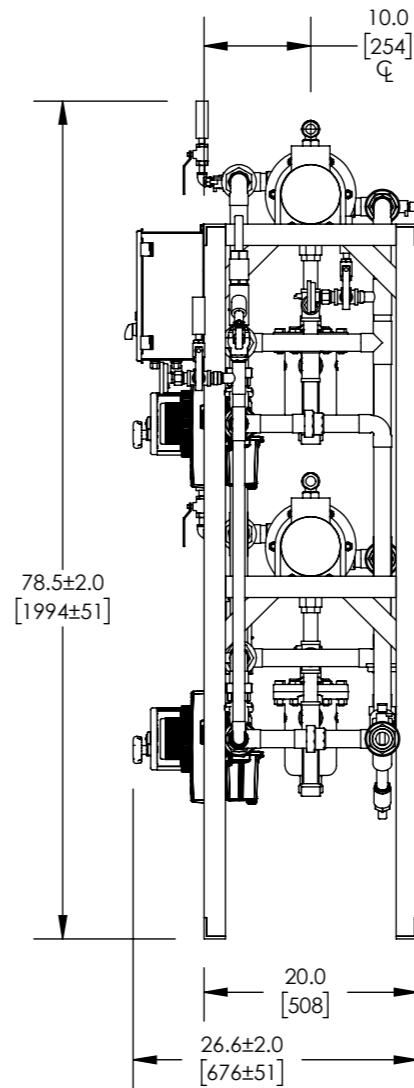
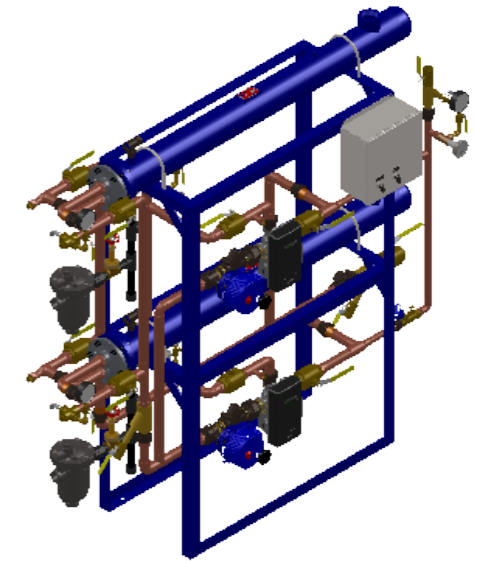

PROJECT NAME:

TAG:

ITEM	DESCRIPTION	CONNECTION
1	COLD WATER INLET	1-1/2" NPT
2	MIXED WATER OUTLET	1-1/2" SWT
3	RECIRC WATER INLET	1" NPT
4	STEAM INLET (2)	2-1/2" NPT
5	CONDENSATE OUTLET (2)	1" NPT 8131B
6	ELECTRICAL PANEL	110VAC @2A
7	DRV40 (2)	1-1/2" NPT
8	N.C. ACTUATED BALL VALVE SAFETY SHUT OFF (2)	1-1/2" NPT
9	THERMOMETER (3)	1/2" NPT
10	CIP CONNECTION (4)	1" NPT
11	SRV (PRESSURE) PIPE TO DRAIN (2)	1/4" NPT
12	SRV (CONNECTION FOR USER SUPPLIED T&P) (2)	3/4" NPT
13	AIR VENT (2)	3/4" NPT
14	VACUUM BREAKER (2)	1/2" NPT
15	BLOWDOWN (2)	3/4" NPT
16	PRESSURE GAUGE(5)	1/4" NPT
17	BALANCING VALVE (2)	1" NPT
18	BLOWDOWN	1/2" NPT
ITEM	MATERIAL	
	PIPING	COPPER TYPE "L"
	EXCHANGER SHELL MATL.	CARBON STEEL
	EXCHANGER TUBE MATL.	ADMIRALTY BRASS

NOTE(S):

- ALL DIMENSIONS +/-0.5 [13] UNLESS OTHERWISE SHOWN.
- COMPLETE ASSEMBLY LEAD FREE COMPLIANT - THE WETTED SURFACE OF THIS PRODUCT CONTACTED BY CONSUMABLE WATER CONTAINS LESS THAN ONE QUARTER OF ONE PERCENT (0.25%) OF LEAD BY WEIGHT.
- PACKAGE INCLUDES ALL REQUIRED INLET CHECK VALVES AND STRAINERS ON DOMESTIC SIDE.
- DRV, SAFETY SHUT OFF AND ELECTRICAL PANEL ARE PREWIRED TO PROVIDE A SINGLE ELECTRICAL LANDING POINT AT THE PANEL.

 DO NOT SCALE DRAWING TOLERANCES UNLESS OTHERWISE SPECIFIED DIMENSIONING ENGLISH [mm]		
FRACTIONAL ± 1/64 ANGULAR: ± 2		
DECIMAL	.XXXX ± .0005	MM
	.XXX ± .005	.010
	.XX ± .015	.10
	.X	.3

NAME	DATE
CFG	5/18/2015

ARMSTRONG INTERNATIONAL
Copyright © 2010 ARMSTRONG INTERNATIONAL, INC.

DF535P40-40BS

MATERIAL	SHEET 1 OF 1
REV	SALES