

Statutory Declaration Registration of Fittings

(a) Design Qualification

I¹ Jonathan Hubbard
(Name of applicant)

Quality Assurance Manager
(Position eg, president, plant manager, chief eng.)

of Armstrong International, Inc.
(name of company)

Located at 816 Maple Street, Three Rivers, MI 49093
(plant address)



REGISTERED

C.R.N.: CSA-OE10876-56R1

Signed: R. Barnes

Date: FEB-29-2016

178 Rexdale Boulevard, Toronto, ON Canada M9W 1R3

do solemnly declare that the fittings listed hereunder, which are subject to the Boilers & Pressure Vessels Act:

comply with all the requirements of the ANSI/ASME codes as to their dimensions, material, identification & service for which are required:

Or

are not covered by the provisions of the ANSI/ASME codes, and are therefore constructed to comply with ASME B31.1/B31.3 code and standard, and are designed to the best current engineering practice, as shown by the supporting test data.

(b) Quality control of Manufacture

I further declare the manufacture of these fittings is controlled by a quality control program which complies with the requirements of ISO 9001:2008, and has been verified by the following authority or authorized agency HSB Registration Services

The fittings² covered by this declaration, for which I seek registration, are Category E

In support of the application, the following information, calculations and/or test data are attached:

Models LS & MS Steam Traps: See page two for document listing.

Declared before me at Three Rivers
In the MI county of St. Joseph
The 13th day of January AD 2016

Robert M. Ryan
ROBERTA M. RYAN
Notary Public (Notary for paths)
My Commission Expires Sept. 13, 2018

Jonathan Hubbard
Signature of Declarer

For Official Use Only

The application is accepted for registration in Category E in accordance with the Boilers and Pressure Vessels Act and CSA Standard B51.

This registration must be revalidated after ten (10) years from the date of acceptance.

Expiry date: FEB-25-2026

Registered Number CRN CSA-OE10876-56R1

For the Chief Inspector

Date FEB-29-2016



R. BARNES

¹ Three completed copies of Statutory Declaration form together with three copies of Catalogs, drawings of Bulletins illustrating above fittings shall be submitted.

² All fittings are required to be registered in the name of the Manufacturer.

³ This form shall be completed and signed by the president or highest official in the manufacturing plant where the fitting is produced.



To:	Jonathan Hubbard	From:	Janet Townsend
Company:	Armstrong International	Phone:	416-747-4291
Pages:	6	Location:	Toronto
Our File:	ANR-3943	Date:	February 29, 2016

Your File: A2016-58

Subject: Request for Design Registration

Dear Mr. Hubbard,

CSA has reviewed the documentation submitted by Armstrong International Inc. . These fittings have been registered by CSA for the Province of Québec. In accordance with an agreement between CSA, the Provinces of Québec and Saskatchewan; this registration is recognized by Quebec and Saskatchewan. These fittings are acceptable for use in these Provinces.

The letters CSA will be applied as a prefix to the CRN indicate which fittings have been registered in this manner. A copy of the stamped Statutory Declaration is attached.

The CRN is CSA-0E10876.56R1 .

The cost for this service is 820.00 plus HST.

A copy of the Statutory Declaration with an original stamp affixed will be forwarded to you along with our invoice by regular mail.

Yours truly

A handwritten signature in cursive script that reads 'Janet Townsend'.

Janet Townsend
Account Manager
CSA Group
www.csagroup.org

DIMENSIONS & DATA CERTIFIED FOR:

Representative:

Order:

Customer:

Order:

Project:

Requirements:

By:

Date:

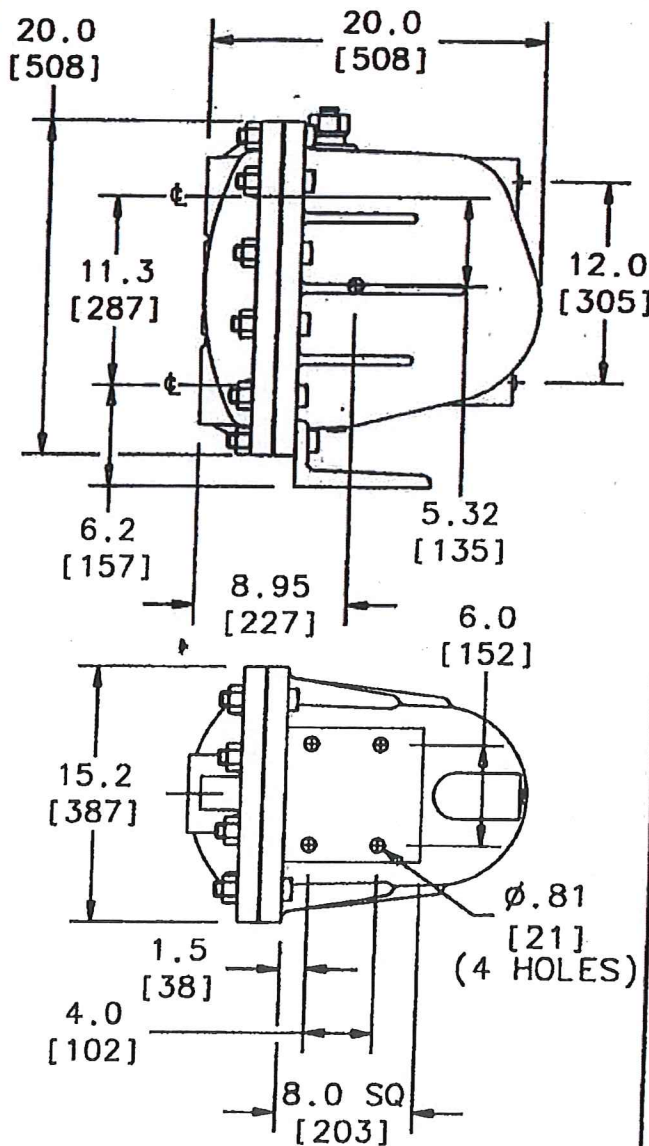

NAME OF PART

MATERIAL

Cap & Body	ASTM A216 Grade WCB
Cap Bolting	ASTM A193 Grade B7
Cap Gaskets	GRAFOIL GRADE GHN
Valve	ASTM A382 T440C
Floot	ASTM A240 T304 SS
Cap Extension	ASTM A351 T304 SS Grade CF8
Mechanism	ASTM A276 T304 SS
Balanced Pressure Thermostatic Air Vent	ASTM A240 T304 SS Shell & Bronze/Phosphor Bellows
Mounting Bracket	ASTM A36

TECHNICAL SPECIFICATIONS

STANDARD CONN. SIZES	2(DN50) & 2-1/2(DN65)
Weight	290 [132 kgs] \pm 4[2kgs]
Maximum Allowable Pressure (Vessel Design)	450 psig [31 bar] at 500°F [260°C]

 **Armstrong International, Inc.**
 Three Rivers Division
 Three Rivers, MI 49093
 (269) 273-1415 Fax(269) 278-6555
 Posted on Armstrong's homepage www.armstrong-intl.com

Product

**DRAIN TRAP
LS (CRN)**

CD No.

CD1316

REV: A

Date

1/23/06

BY: SRW



DIMENSIONS & DATA CERTIFIED FOR:

Representative:

Order:

Customer:

Order:

Project:

Requirements:

By:

Date:

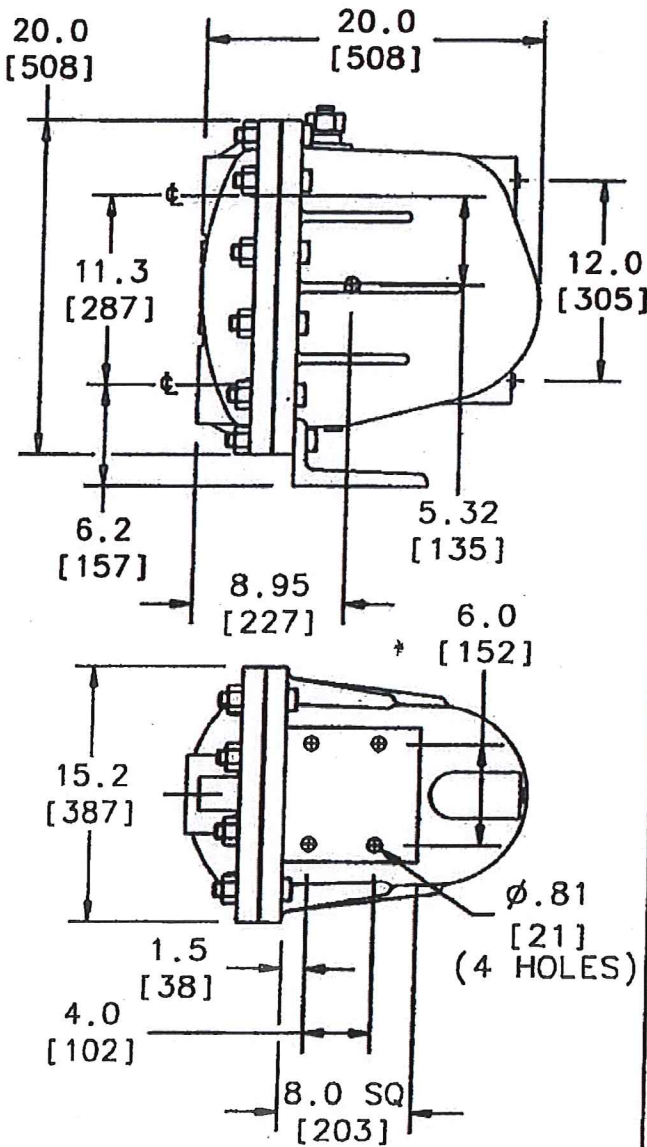

NAME OF PART

MATERIAL

Cap & Body	ASTM A216 Grade WCB
Cap Bolting	ASTM A193 Grade B7
Cap Gaskets	GRAFOIL GRADE GNN
Valve	ASTM A582 T440C
Floot	ASTM A240 T304 SS
Cap Extension	ASTM A747 Grade 17-4 Ph C87Cu-1
Mechanism	ASTM A276 T304 SS
Balanced Pressure	ASTM A240 T304 SS, Shell &
Thermostatic Air Vent	Bronze/Phosphor Bellows
Mounting Bracket	ASTM A36

TECHNICAL SPECIFICATIONS

STANDARD CONN. SIZES	3[DN80]
Weight	290 [132 kgs] ±4[2kgs]
Maximum Allowable Pressure (Vessel Design)	450 psig [31 bar] at 500°F [260°C]



Armstrong International, Inc.
 Three Rivers Division
 Three Rivers, MI 49093
 (269) 273-1415 Fax(269) 278-6555
 Posted on Armstrong's homepage www.armstrong-intl.com

Product

**DRAIN TRAP
MS (CRN)**

CD No.

CD1317

REV: A

Date

1/23/06

BY: SRW

**HSB REGISTRATION SERVICES
595 E. SWEDES FORD ROAD
WAYNE, PENNSYLVANIA 19087**

Certificate of Registration

This is to certify that:

**Armstrong International, Inc.
816 Maple Street
Three Rivers, MI 49093**

Has established and applied a Quality Management System for:
**Design and Manufacture of Steam Traps,
Condensate Handling Equipment, Air Vents, Liquid Drainers,
Strainers, Purgers, Valves, Steam Diagnostic Equipment,
Humidifiers, and Related Equipment**

*Proof has been furnished that the requirements according to
ISO 9001:2008
are fulfilled.*

EA Code: 14,17,18

Certificate Number: HQ Q 383

Initial Audit Date: October 3, 2001

Effective Date: January 12, 2015

Expiration Date: January 11, 2018

Revision Date:

Signed on behalf of HSB Registration Services



Certificate Number: HQ Q 383

Page 1 of 1