



Armstrong®

STEAM CONSERVATION GUIDELINES
FOR CONDENSATE DRAINAGE



Table of Contents

Recommendation Charts and Instructions for Use.....	4
Steam Tables.....	5
Steam...Basic Concepts	7
The Inverted Bucket Steam Trap.....	11
The Float & Thermostatic Steam Trap.....	13
The Controlled Disc Steam Trap	14
The Thermostatic Steam Trap	15
The Automatic Differential Condensate Controller	16
Steam Trap Selection	17
How to Trap:	
Steam Distribution Systems.....	19
Steam Tracer Lines.....	23
Superheated Steam Lines.....	25
Space Heating Equipment.....	27
Process Air Heaters.....	30
Shell and Tube Heat Exchangers & Submerged Coils	31
Evaporators.....	34
Jacketed Kettles.....	37
Closed Stationary Steam Chamber Equipment	39
Rotating Dryers Requiring Syphon Drainage.....	41
Flash Tanks.....	43
Steam Absorption Machines	45
Trap Selection and Safety Factors.....	46
Installation and Testing	47
Troubleshooting	51
Pipe Sizing Steam Supply and Condensate Return Lines.....	52
Useful Engineering Tables.....	55
Conversion Factors	56
Specific Heat - Specific Gravity	57

Bringing Energy Down to Earth

Say energy. Think environment. And vice versa.

Any company that is energy conscious is also environmentally conscious. Less energy consumed means less waste, fewer emissions and a healthier environment.

In short, bringing energy and environment together lowers the cost industry must pay for both. By helping companies manage energy, Armstrong products and services are also helping to protect the environment.

Armstrong has been sharing know-how since we invented the energy-efficient inverted bucket steam trap in 1911. In the years since, customers' savings have proven again and again that knowledge not shared is energy wasted.

Armstrong's developments and improvements in steam trap design and function have led to countless savings in energy, time and money. This section has grown out of our decades of sharing and expanding what we've learned. It deals with the operating principles of steam traps and outlines their specific applications to a wide variety of products and industries. You'll find it a useful complement to other Armstrong literature and the Armstrong Steam-A-ware™ software program for sizing and selecting steam traps, pressure reducing valves and water heaters, which can be requested through Armstrong's Web site, armstronginternational.com.

This section also includes Recommendation Charts that summarize our findings on which type of trap will give optimum performance in a given situation and why.

IMPORTANT: This section is intended to summarize general principles of installation and operation of steam traps, as outlined above. Actual installation and operation of steam trapping equipment should be performed only by experienced personnel. Selection or installation should always be accompanied by competent technical assistance or advice. This data should never be used as a substitute for such technical advice or assistance. We encourage you to contact Armstrong or its local representative for further details.



Instructions for Using the Recommendation Charts

A quick reference Recommendation Chart appears throughout the “HOW TO TRAP” sections of this catalog, pages 19 to 45.

A feature code system (ranging from A to Q) supplies you with “at-a-glance” information.

The chart covers the type of steam traps and the major advantages that Armstrong feels are superior for each particular application.

For example, assume you are looking for information concerning the proper trap to use on a gravity drained jacketed kettle. You would:

1. Turn to the “How to Trap Jacketed Kettles” section, pages 37 to 38, and look in the lower right-hand corner of page 37. The Recommendation Chart located there is reprinted below for your convenience.(Each section has a Recommendation Chart.)
2. Find “Jacketed Kettles, Gravity Drain” in the first column under “Equipment Being Trapped” and read to the right for Armstrong’s “1st Choice and Feature Code.” In this case, the first choice is an IBLV and the feature code letters B, C, E, K, N are listed.

3. Now refer to Chart CG-2 below, titled “How Various Types of Steam Traps Meet Specific Operating Requirements” and read down the extreme left-hand column to each of the letters B, C, E, K, N. The letter “B,” for example, refers to the trap’s ability to provide energy-conserving operation.
4. Follow the line for “B” to the right until you reach the column that corresponds to our first choice, in this case the inverted bucket. Based on tests and actual operating conditions, the energy-conserving performance of the inverted bucket steam trap has been rated “Excellent.” Follow this same procedure for the remaining letters.

Abbreviations

- IB Inverted Bucket Trap
- IBLV Inverted Bucket Large Vent
- BM Bimetallic Trap
- F&T Float and Thermostatic Trap
- CD Controlled Disc Trap
- DC Automatic Differential
Condensate Controller
- CV Check Valve
- T Thermic Bucket
- PRV Pressure Reducing Valve

Chart CG-1. Recommendation Chart (See chart below for “Feature Code” References.)		
Equipment Being Trapped	1st Choice and Feature Code	Alternate Choice
Jacketed Kettles Gravity Drain	IBLV B, C, E, K, N	F&T or Thermostatic
Jacketed Kettles Syphon Drain	DC B, C, E, G, H, K, N, P	IBLV

Chart CG-2. How Various Types of Steam Traps Meet Specific Operating Requirements								
Feature Code	Characteristic	IB	BM	F&T	Disc	Thermostatic Wafer	DC	Orifice
A	Method of Operation	(1) Intermittent	(2) Intermittent	Continuous	Intermittent	(2) Intermittent	Continuous	Continuous
B	Energy Conservation (Time in Service)	Excellent	Excellent	Good	Poor	Fair	(3) Excellent	Poor
C	Resistance to Wear	Excellent	Excellent	Good	Poor	Fair	Excellent	Poor
D	Corrosion Resistance	Excellent	Excellent	Good	Excellent	Good	Excellent	Good
E	Resistance to Hydraulic Shock	Excellent	Excellent	Poor	Excellent	(4) Poor	Excellent	Good
F	Vents Air and CO2 at Steam Temperature	Yes	No	No	No	No	Yes	Poor
G	Ability to Vent Air at Very Low Pressure (1/4 psig)	Poor	(5) NR	Excellent	(5) NR	Good	Excellent	Poor
H	Ability to Handle Start-Up Air Loads	Fair	Excellent	Excellent	Poor	Excellent	Excellent	Poor
I	Operation Against Back Pressure	Excellent	Excellent	Excellent	Poor	Excellent	Excellent	Poor
J	Resistance to Damage From Freezing	(6) Good	Good	Poor	Good	Good	Good	Excellent
K	Ability to Purge System	Excellent	Good	Fair	Excellent	Good	Excellent	Poor
L	Performance on Very Light Loads	Excellent	Excellent	Excellent	Poor	Excellent	Excellent	Poor
M	Responsiveness to Slugs of Condensate	Immediate	Delayed	Immediate	Delayed	Delayed	Immediate	Poor
N	Ability to Handle Dirt	Excellent	Fair	Poor	Poor	Fair	Excellent	Poor
O	Comparative Physical Size (7)	Large	Small	Large	Small	Small	Large	Small
P	Ability to Handle “Flash Steam”	Fair	Poor	Poor	Poor	Poor	Excellent	Poor
Q	Mechanical Failure (Open or Closed)	Open	Open	Closed	(8) Open	(9)	Open	NA

(1) Drainage of condensate is continuous. Discharge is intermittent.

(2) Can be continuous on low load.

(3) Excellent when “secondary steam” is utilized.

(4) Bimetallic and wafer traps – good.

(5) Not recommended for low pressure operations.

(6) Cast iron traps not recommended.

(7) In welded stainless steel construction – medium.

(8) Can fail closed due to dirt.

(9) Can fail either open or closed, depending upon the design of the bellows.

Designs, materials, weights and performance ratings are approximate and subject to change without notice. Visit armstronginternational.com for up-to-date information.

Steam Tables

What They Are...How to Use Them

The heat quantities and temperature/pressure relationships referred to in this section are taken from the Properties of Saturated Steam table.

Definitions of Terms Used

Saturated Steam is pure steam at the temperature that corresponds to the boiling temperature of water at the existing pressure.

Absolute and Gauge Pressures

Absolute pressure is pressure in pounds per square inch (psia) above a perfect vacuum. Gauge pressure is pressure in pounds per square inch above atmospheric pressure, which is 14.7 pounds per square inch absolute. Gauge pressure (psig) plus 14.7 equals absolute pressure. Or, absolute pressure minus 14.7 equals gauge pressure.

Pressure/Temperature Relationship

(Columns 1, 2 and 3). For every pressure of pure steam there is a corresponding temperature. Example: The temperature of 250 psig pure steam is always 406°F.

Heat of Saturated Liquid (Column 4).

This is the amount of heat required to raise the temperature of a pound of water from 32°F to the boiling point at the pressure and temperature shown. It is expressed in British thermal units (Btu).

Latent Heat or Heat of Vaporization

(Column 5). The amount of heat (expressed in Btu) required to change a pound of boiling water to a pound of steam. This same amount of heat is released when a pound of steam is condensed back into a pound of water. This heat quantity is different for every pressure/temperature combination, as shown in the steam table.

Total Heat of Steam (Column 6). The sum of the Heat of the Liquid (Column 4) and Latent Heat (Column 5) in Btu. It is the total heat in steam above 32°F.

Specific Volume of Liquid (Column 7).

The volume per unit of mass in cubic feet per pound.

Specific Volume of Steam (Column 8).

The volume per unit of mass in cubic feet per pound.

How the Table Is Used

In addition to determining pressure/temperature relationships, you can compute the amount of steam that will be condensed by any heating unit of known Btu output. Conversely, the

table can be used to determine Btu output if steam condensing rate is known. In the application portion of this section, there are several references to the use of the steam table.

Table CG-1. Properties of Saturated Steam
(Abstracted from Keenan and Keyes, THERMODYNAMIC PROPERTIES OF STEAM, by permission of John Wiley & Sons, Inc.)

	Col. 1 Gauge Pressure	Col. 2 Absolute Pressure (psia)	Col. 3 Steam Temp. (°F)	Col. 4 Heat of Sat. Liquid (Btu/lb)	Col. 5 Latent Heat (Btu/lb)	Col. 6 Total Heat of Steam (Btu/lb)	Col. 7 Specific Volume of Sat. Liquid (cu ft/lb)	Col. 8 Specific Volume of Sat. Steam (cu ft/lb)
Inches of Vacuum	29.743	0.08854	32.00	0.00	1075.8	1075.8	0.016022	3306.00
	29.515	0.2	53.14	21.21	1063.8	1085.0	0.016027	1526.00
	27.886	1.0	101.74	69.70	1036.3	1106.0	0.016136	333.60
	19.742	5.0	162.24	130.13	1001.0	1131.0	0.016407	73.52
	9.562	10.0	193.21	161.17	982.1	1143.3	0.016590	38.42
	7.536	11.0	197.75	165.73	979.3	1145.0	0.016620	35.14
	5.490	12.0	201.96	169.96	976.6	1146.6	0.016647	32.40
	3.454	13.0	205.88	173.91	974.2	1148.1	0.016674	30.06
PSIG	1.418	14.0	209.56	177.61	971.9	1149.5	0.016699	28.04
	0.0	14.696	212.00	180.07	970.3	1150.4	0.016715	26.80
	1.3	16.0	216.32	184.42	967.6	1152.0	0.016746	24.75
	2.3	17.0	219.44	187.56	965.5	1153.1	0.016768	23.39
	5.3	20.0	227.96	196.16	960.1	1156.3	0.016830	20.09
	10.3	25.0	240.07	208.42	952.1	1160.6	0.016922	16.30
	15.3	30.0	250.33	218.82	945.3	1164.1	0.017004	13.75
	20.3	35.0	259.28	227.91	939.2	1167.1	0.017078	11.90
	25.3	40.0	267.25	236.03	933.7	1169.7	0.017146	10.50
	30.3	45.0	274.44	243.36	928.6	1172.0	0.017209	9.40
	40.3	55.0	287.07	256.30	919.6	1175.9	0.017325	7.79
	50.3	65.0	297.97	267.50	911.6	1179.1	0.017429	6.66
	60.3	75.0	307.60	277.43	904.5	1181.9	0.017524	5.82
	70.3	85.0	316.25	286.39	897.8	1184.2	0.017613	5.17
	80.3	95.0	324.12	294.56	891.7	1186.2	0.017696	4.65
	90.3	105.0	331.36	302.10	886.0	1188.1	0.017775	4.23
	100.0	114.7	337.90	308.80	880.0	1188.8	0.017850	3.88
	110.3	125.0	344.33	315.68	875.4	1191.1	0.017922	3.59
	120.3	135.0	350.21	321.85	870.6	1192.4	0.017991	3.33
	125.3	140.0	353.02	324.82	868.2	1193.0	0.018024	3.22
	130.3	145.0	355.76	327.70	865.8	1193.5	0.018057	3.11
	140.3	155.0	360.50	333.24	861.3	1194.6	0.018121	2.92
	150.3	165.0	365.99	338.53	857.1	1195.6	0.018183	2.75
	160.3	175.0	370.75	343.57	852.8	1196.5	0.018244	2.60
	180.3	195.0	379.67	353.10	844.9	1198.0	0.018360	2.34
	200.3	215.0	387.89	361.91	837.4	1199.3	0.018470	2.13
	225.3	240.0	397.37	372.12	828.5	1200.6	0.018602	1.92
	250.3	265.0	406.11	381.60	820.1	1201.7	0.018728	1.74
		300.0	417.33	393.84	809.0	1202.8	0.018896	1.54
		400.0	444.59	424.00	780.5	1204.5	0.019340	1.16
		450.0	456.28	437.20	767.4	1204.6	0.019547	1.03
		500.0	467.01	449.40	755.0	1204.4	0.019748	0.93
	600.0	486.21	471.60	731.6	1203.2	0.02013	0.77	
	900.0	531.98	526.60	668.8	1195.4	0.02123	0.50	
	1200.0	567.22	571.70	611.7	1183.4	0.02232	0.36	
	1500.0	596.23	611.60	556.3	1167.9	0.02346	0.28	
	1700.0	613.15	636.30	519.6	1155.9	0.02428	0.24	
	2000.0	635.82	671.70	463.4	1135.1	0.02565	0.19	
	2500.0	668.13	730.60	360.5	1091.1	0.02860	0.13	
	2700.0	679.55	756.20	312.1	1068.3	0.03027	0.11	
	3206.2	705.40	902.70	0.0	902.7	0.05053	0.05	

Flash Steam (Secondary)

What is flash steam? When hot condensate or boiler water, under pressure, is released to a lower pressure, part of it is re-evaporated, becoming what is known as flash steam.

Why is it important? This flash steam is important because it contains heat units that can be used for economical plant operation—and which are otherwise wasted.

How is it formed? When water is heated at atmospheric pressure, its temperature rises until it reaches 212°F, the highest temperature at which water can exist at this pressure. Additional heat does not raise the temperature, but converts the water to steam.

The heat absorbed by the water in raising its temperature to boiling point is called “sensible heat” or heat of saturated liquid. The heat required to convert water at boiling point to steam at the same temperature is called “latent heat.” The unit of heat in common use is the Btu, which is the amount of heat required to raise the temperature of one pound of water 1°F at atmospheric pressure.

If water is heated under pressure, however, the boiling point is higher than 212°F, so the sensible heat required is greater. The higher the pressure, the higher the boiling temperature and the higher the heat content. If pressure is reduced, a certain amount of sensible heat is released. This excess heat will be absorbed in the form of latent heat, causing part of the water to “flash” into steam.

Condensate at steam temperature and under 100 psig pressure has a heat content of 308.8 Btu per pound. (See Column 4 in Steam Table.) If this condensate is discharged to atmospheric pressure (0 psig), its heat content instantly drops to 180 Btu per pound. The surplus of 128.8 Btu re-evaporates or flashes a portion of the condensate. The percentage that will flash to steam can be computed using the formula:

$$\% \text{ flash steam} = \frac{SH - SL}{H} \times 100$$

SH = Sensible heat in the condensate at the higher pressure before discharge.

SL = Sensible heat in the condensate at the lower pressure to which discharge takes place.

H = Latent heat in the steam at the lower pressure to which the condensate has been discharged.

$$\% \text{ flash steam} = \frac{308.8 - 180}{970.3} \times 100 = 13.3\%$$

Chart CG-3 shows the amount of secondary steam that will be formed when discharging condensate to different pressures.

Chart CG-3.

Percentage of flash steam formed when discharging condensate to reduced pressure.

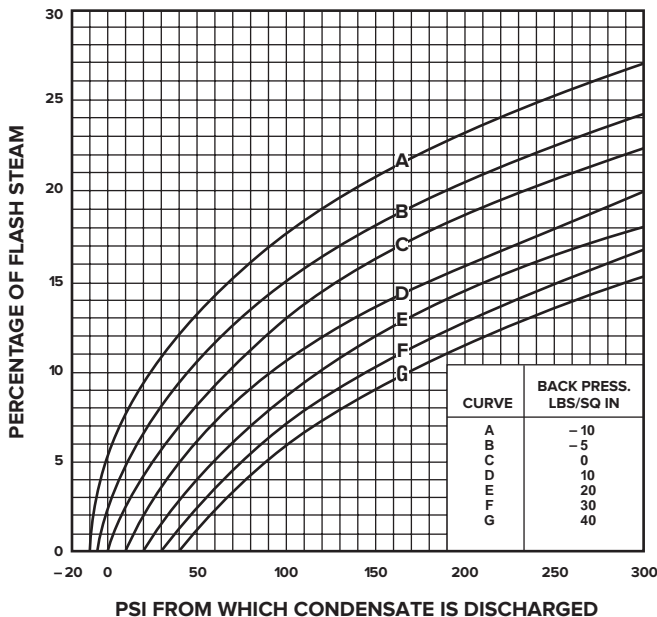
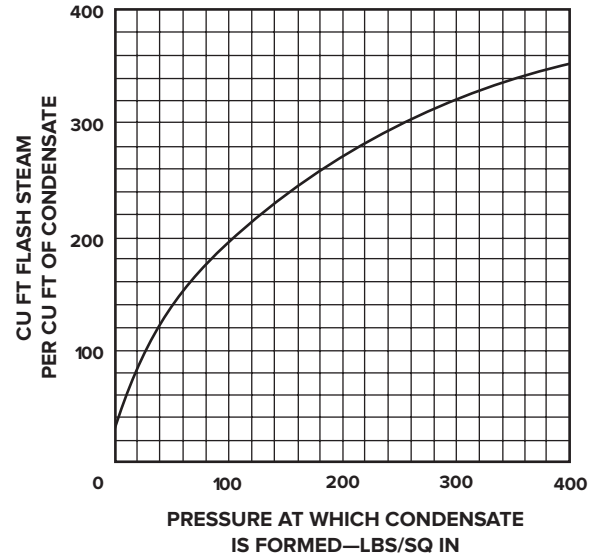

Chart CG-4.

Volume of flash steam formed when one cubic foot of condensate is discharged to atmospheric pressure.



Steam...Basic Concepts

Steam is an invisible gas generated by adding heat energy to water in a boiler. Enough energy must be added to raise the temperature of the water to the boiling point. Then additional energy—without any further increase in temperature—changes the water to steam.

Steam is a very efficient and easily controlled heat transfer medium. It is most often used for transporting energy from a central location (the boiler) to any number of locations in the plant where it is used to heat air, water or process applications.

As noted, additional Btu are required to make boiling water change to steam. These Btu are not lost but stored in the steam ready to be released to heat air, cook tomatoes, press pants or dry a roll of paper.

The heat required to change boiling water into steam is called the heat of vaporization or latent heat. The quantity is different for every pressure/temperature combination, as shown in the steam tables.

Steam at Work...

How the Heat of Steam Is Utilized

Heat flows from a higher temperature level to a lower temperature level in a process known as heat transfer. Starting in the combustion chamber of the boiler, heat flows through the boiler tubes to the water. When the higher pressure in the boiler pushes steam out, it heats the pipes of the distribution system. Heat flows from the steam through the walls of the pipes into the cooler surrounding air. This heat transfer changes some of the steam back into water. That's why distribution lines are usually insulated to minimize this wasteful and undesirable heat transfer.

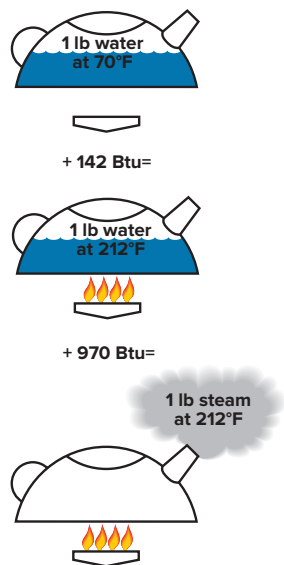

Figure CG-1. These drawings show how much heat is required to generate one pound of steam at atmospheric pressure. Note that it takes 1 Btu for every 1°F increase in temperature up to the boiling point, but that it takes more Btu to change water at 212°F to steam at 212°F.

When steam reaches the heat exchangers in the system, the story is different. Here the transfer of heat from the steam is desirable. Heat flows to the air in an air heater, to the water in a water heater or to food in a cooking kettle. Nothing should interfere with this heat transfer.

Condensate Drainage...

Why It's Necessary

Condensate is the by-product of heat transfer in a steam system. It forms in the distribution system due to unavoidable radiation. It also forms in heating and process equipment as a result of desirable heat transfer from the steam to the substance heated. Once the steam has condensed and given up its valuable latent heat, the hot condensate must be removed immediately. Although the available heat in a pound of condensate is negligible as compared to a pound of steam, condensate is still valuable hot water and should be returned to the boiler.

Definitions

- **The Btu.** A Btu—British thermal unit—is the amount of heat energy required to raise the temperature of one pound of cold water by 1°F. Or, a Btu is the amount of heat energy given off by one pound of water in cooling, say, from 70°F to 69°F.
- **Temperature.** The degree of hotness with no implication of the amount of heat energy available.
- **Heat.** A measure of energy available with no implication of temperature. To illustrate, the one Btu that raises one pound of water from 39°F to 40°F could come from the surrounding air at a temperature of 70°F or from a flame at a temperature of 1,000°F.

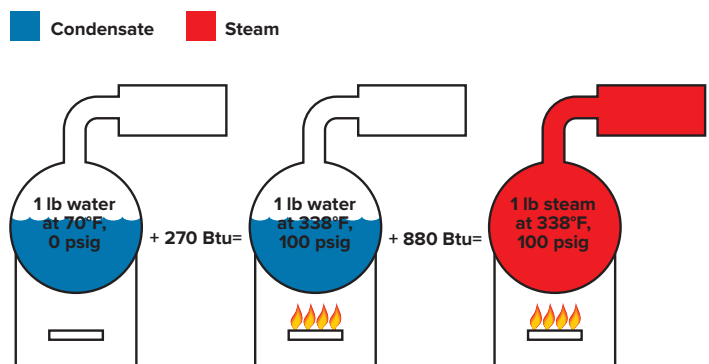

Figure CG-2. These drawings show how much heat is required to generate one pound of steam at 100 pounds per square inch pressure. Note the extra heat and higher temperature required to make water boil at 100 pounds pressure than at atmospheric pressure. Note, too, the lesser amount of heat required to change water to steam at the higher temperature.

The need to drain the distribution system. Condensate lying in the bottom of steam lines can be the cause of one kind of water hammer. Steam traveling at up to 100 miles per hour makes “waves” as it passes over this condensate (Fig. CG-4). If enough condensate forms, high-speed steam pushes it along, creating a dangerous slug that grows larger and larger as it picks up liquid in front of it. Anything that changes the direction—pipe fittings, regulating valves, tees, elbows, blind flanges—can be destroyed. In addition to damage from this “battering ram,” high-velocity water may erode fittings by chipping away at metal surfaces.

The need to drain the heat transfer unit. When steam comes in contact with condensate cooled below the temperature of steam, it can produce another kind of water hammer known as thermal shock. Steam occupies a much greater volume than condensate, and when it collapses suddenly, it can send shock waves throughout the system. This form of water hammer can damage equipment, and it signals that condensate is not being drained from the system.

Obviously, condensate in the heat transfer unit takes up space and reduces the physical size and capacity of the equipment. Removing it quickly keeps the unit full of steam (Fig. CG-5). As steam condenses, it forms a film of water on the inside of the heat exchanger. Non-condensable gases do not change into liquid and flow away by gravity. Instead, they accumulate as a thin film on the surface of the heat exchanger—along with dirt and scale. All are potential barriers to heat transfer (Fig. CG-3).

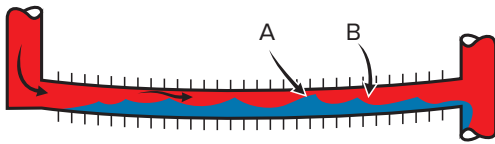

Figure CG-4. Condensate allowed to collect in pipes or tubes is blown into waves by steam passing over it until it blocks steam flow at point A. Condensate in area B causes a pressure differential that allows steam pressure to push the slug of condensate along like a battering ram.

The need to remove air and CO₂. Air is always present during equipment start-up and in the boiler feedwater. Feedwater may also contain dissolved carbonates, which release carbon dioxide gas. The steam velocity pushes the gases to the walls of the heat exchangers, where they may block heat transfer. This compounds the condensate drainage problem, because these gases must be removed along with the condensate.

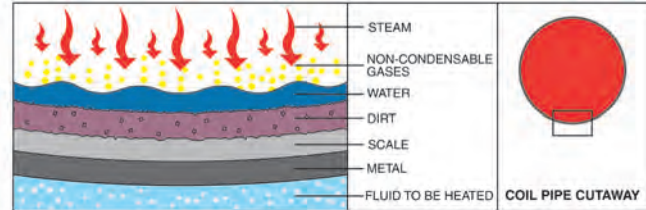

Figure CG-3. Potential barriers to heat transfer: steam heat and temperature must penetrate these potential barriers to do their work.

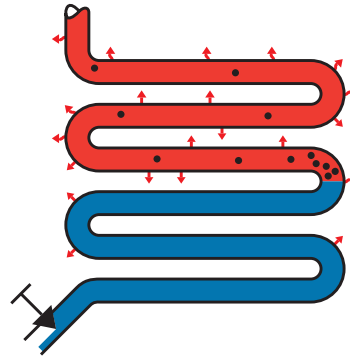

Figure CG-5. Coil half full of condensate can't work at full capacity.

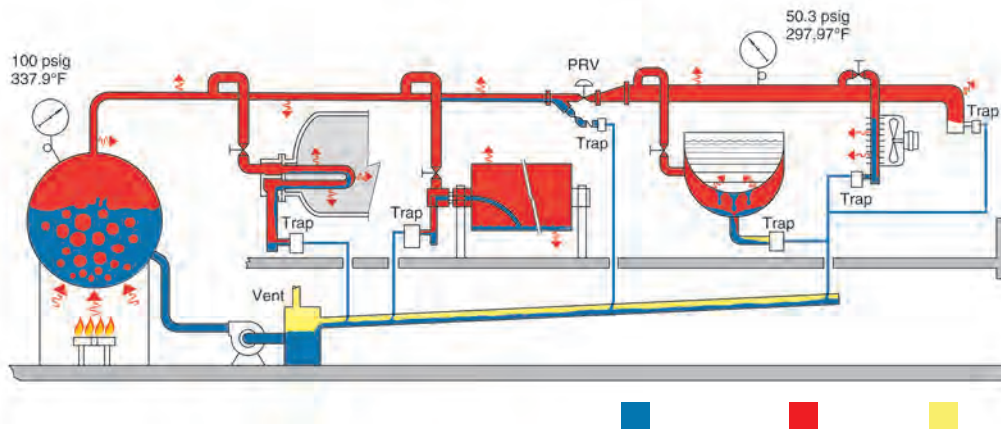

Figure CG-6. Note that heat radiation from the distribution system causes condensate to form and, therefore, requires steam traps at natural low points or ahead of control valves. In the heat exchangers, traps perform the vital function of removing the condensate before it becomes a barrier to heat transfer. Hot condensate is returned through the traps to the boiler for reuse.

Steam...Basic Concepts

Effect of Air on Steam Temperature

When air and other gases enter the steam system, they consume part of the volume that steam would otherwise occupy. The temperature of the air/steam mixture falls below that of pure steam. Figure 7 explains the effect of air in steam lines. Table CG-2 and Chart CG-5 show the various temperature reductions caused by air at various percentages and pressures.

Effect of Air on Heat Transfer

The normal flow of steam toward the heat exchanger surface carries air and other gases with it. Since they do not condense and drain by gravity, these non-condensable gases set up a barrier between the steam and the heat exchanger surface. The excellent insulating properties of air reduce heat transfer. In fact, under certain conditions as little as 1/2 of 1% by volume of air in steam can reduce heat transfer efficiency by 50% (Fig. CG-8).

Pressure (psig)	Temp. of Steam, No Air Present (°F)	Temp. of Steam Mixed With Various Percentages of Air (by Volume) (°F)		
		10%	20%	30%
10.3	240.1	234.3	228.0	220.9
25.3	267.3	261.0	254.1	246.4
50.3	298.0	291.0	283.5	275.1
75.3	320.3	312.9	304.8	295.9
100.3	338.1	330.3	321.8	312.4

Figure CG-7. Chamber containing air and steam delivers only the heat of the partial pressure of the steam, not the total pressure.

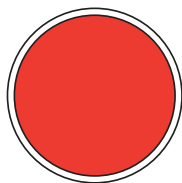

Steam chamber 100% steam
Total pressure 100 psia
Steam pressure 100 psia
Steam temperature 327.8°F

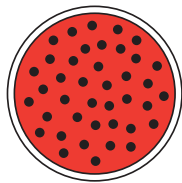

Steam chamber 90% steam and 10% air
Total pressure 100 psia
Steam pressure 90 psia
Steam temperature 320.3°F

When non-condensable gases (primarily air) continue to accumulate and are not removed, they may gradually fill the heat exchanger with gases and stop the flow of steam altogether. The unit is then “air bound.”

Corrosion

Two primary causes of scale and corrosion are carbon dioxide (CO₂) and oxygen. CO₂ enters the system as carbonates dissolved in feedwater and, when mixed with cooled condensate, creates carbonic acid. Extremely corrosive, carbonic acid can eat through piping and heat exchangers (Fig. CG-9). Oxygen enters the system as gas dissolved in the cold feedwater. It aggravates the action of carbonic acid, speeding corrosion and pitting iron and steel surfaces (Fig. CG-10).

Eliminating the Undesirables

To summarize, traps must drain condensate because it can reduce heat transfer and cause water hammer. Traps should evacuate air and other non-condensable gases because they can reduce heat transfer by reducing steam temperature and insulating the system. They can also foster destructive corrosion. It's essential to remove condensate, air and CO₂ as quickly and completely as possible. A steam trap, which is simply an automatic valve that opens for condensate, air and CO₂ and closes for steam, does this job. For economic reasons, the steam trap should do its work for long periods with minimum attention.

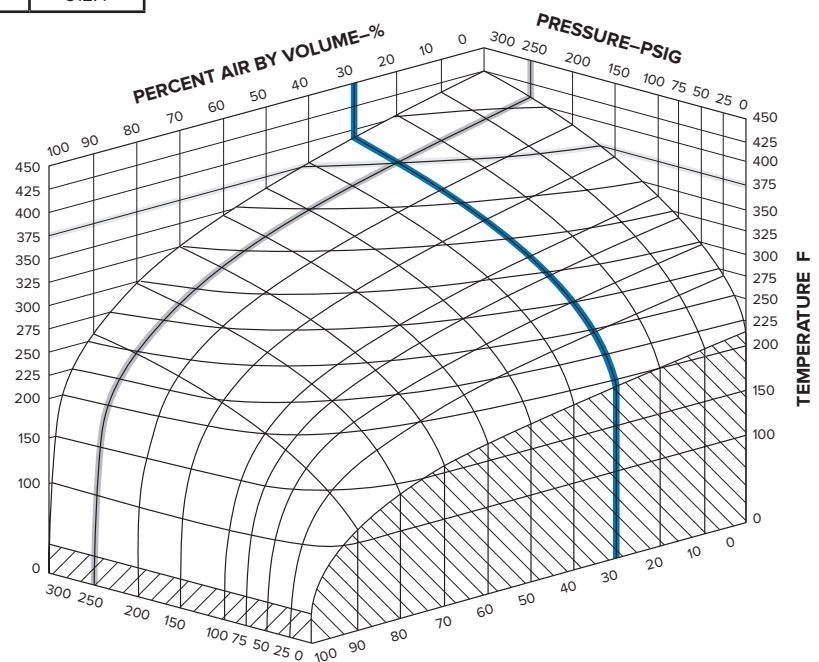

Chart CG-8. Air Steam Mixture

Temperature reduction caused by various percentages of air at differing pressures. This chart determines the percentage of air with known pressure and temperature by determining the point of intersection between pressure, temperature and percentage of air by volume. As an example, assume system pressure of 250 psig with a temperature at the heat exchanger of 375°F. From the chart, it is determined that there is 30% air by volume in the steam.

What the Steam Trap Must Do

The job of the steam trap is to get condensate, air and CO₂ out of the system as quickly as they accumulate. In addition, for overall efficiency and economy, the trap must also provide:

- 1. Minimal steam loss.** Table CG-3 shows how costly unattended steam leaks can be.
- 2. Long life and dependable service.** Rapid wear of parts quickly brings a trap to the point of unavailability. An efficient trap saves money by minimizing trap testing, repair, cleaning, downtime and associated losses.
- 3. Corrosion resistance.** Working trap parts should be corrosion-resistant in order to combat the damaging effects of acidic or oxygen-laden condensate.
- 4. Air venting.** Air can be present in steam at any time and especially on start-up. Air must be vented for efficient heat transfer and to prevent system binding.
- 5. CO₂ venting.** Venting CO₂ at steam temperature will prevent the formation of carbonic acid. Therefore, the steam trap must function at or near steam temperature since CO₂ dissolves in condensate that has cooled below steam temperature.
- 6. Operation against back pressure.** Pressurized return lines can occur both by design and unintentionally. A steam trap should be able to operate against the actual back pressure in its return system.

- 7. Freedom from dirt problems.** Dirt is an ever-present concern since traps are located at low points in the steam system. Condensate picks up dirt and scale in the piping, and solids may carry over from the boiler. Even particles passing through strainer screens are erosive and, therefore, the steam trap must be able to operate in the presence of dirt.

A trap delivering anything less than all these desirable operating/design features will reduce the efficiency of the system and increase costs. When a trap delivers all these features the system can achieve:

1. Fast heat-up of heat transfer equipment
2. Maximum equipment temperature for enhanced steam heat transfer
3. Maximum equipment capacity
4. Maximum fuel economy
5. Reduced labor per unit of output
6. Minimum maintenance and a long trouble-free service life

Sometimes an application may demand a trap without these design features, but in the vast majority of applications the trap which meets all the requirements will deliver the best results.

Figure CG-8. Steam condensing in a heat transfer unit moves air to the heat transfer surface, where it collects or “plates out” to form effective insulation.

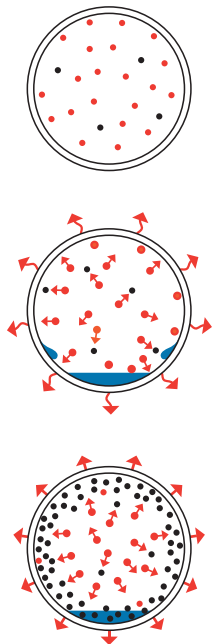

Figure CG-9. CO₂ gas combines with condensate allowed to cool below steam temperature to form carbonic acid, which corrodes pipes and heat transfer units. Note groove eaten away in the pipe illustrated.

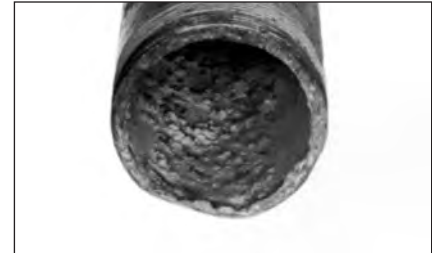

Figure CG-10. Oxygen in the system speeds corrosion (oxidation) of pipes, causing pitting such as shown here.

Figs. CG-9 and CG-10 courtesy of Dearborn Chemical Company.

Table CG-3. Cost of Various Sized Steam Leaks at 100 psi
(Assuming steam costs \$10.00/1,000 lbs)

Size of Orifice		Lbs Steam Wasted Per Month	Total Cost Per Month (USD)	Total Cost Per Year (USD)
1/2"	12, 7 mm	553,000	\$5,530.00	\$66,360.00
7/16"	11, 2 mm	423,500	4,235.00	50,820.00
3/8"	9, 5 mm	311,000	3,110.00	37,320.00
5/16"	7, 9 mm	216,000	2,160.00	25,920.00
1/4"	6, 4 mm	138,000	1,380.00	16,560.00
3/16"	4, 8 mm	78,000	780.00	9,360.00
1/8"	3, 2 mm	34,500	345.00	4,140.00

The steam loss values assume typical condensate load for drip trap applications. Armstrong methodology for steam trap management and condensate return is sanctioned by the Clean Development Mechanism of the United Nations Framework Convention on Climate Change.

The Inverted Bucket Steam Trap

The Armstrong inverted submerged bucket steam trap is a mechanical trap that operates on the difference in density between steam and water. See Fig. CG-11. Steam entering the inverted submerged bucket causes the bucket to float and close the discharge valve. Condensate entering the trap changes the bucket to a weight that sinks and opens the trap valve to discharge the condensate. Unlike other mechanical traps, the inverted bucket also vents air and carbon dioxide continuously at steam temperature.

This simple principle of condensate removal was introduced by Armstrong in 1911. Years of improvement in materials and manufacturing have made today's Armstrong inverted bucket traps virtually unmatched in operating efficiency, dependability and long life.

Long, Energy-Efficient Service Life

At the heart of the Armstrong inverted bucket trap is a unique leverage system that multiplies the force provided by the bucket to open the valve against pressure. There are no fixed pivots to wear or create friction. It is designed to open the discharge orifice for maximum capacity. Since the bucket is open at the bottom, it is resistant to damage from water hammer. Wearing points are heavily reinforced for long life.

An Armstrong inverted bucket trap can continue to conserve energy even in the presence of wear. Gradual wear slightly increases the diameter of the seat and alters the shape and diameter of the ball valve. But as this occurs, the ball merely seats itself deeper—preserving a tight seal.

Reliable Operation

The Armstrong inverted bucket trap owes much of its reliability to a design that makes it virtually free of dirt problems. Note that the valve and seat are at the top of the trap. The larger particles of dirt fall to the bottom, where they are pulverized under the up-and-down action of the bucket. Since the valve of an inverted bucket is either closed or fully open, there is free passage of dirt particles. In addition, the swift flow of condensate from under the bucket's edge creates a unique self-scrubbing action that sweeps dirt out of the trap. The inverted bucket has only two moving parts—the valve lever assembly and the bucket. That means no fixed points, no complicated linkages—nothing to stick, bind or clog.

Corrosion-Resistant Parts

The valve and seat of Armstrong inverted bucket traps are high chrome stainless steel, ground and lapped. All other working parts are wear- and corrosion-resistant stainless steel.

Operation Against Back Pressure

High pressure in the discharge line simply reduces the differential across the valve. As back pressure approaches that of inlet pressure, discharge becomes continuous just as it does on the very low pressure differentials.

Back pressure has no adverse effect on inverted bucket trap operation other than capacity reduction caused by the low differential. There is simply less force required by the bucket to pull the valve open, cycling the trap.

Figure CG-11. Operation of the Inverted Bucket Steam Trap (at pressures close to maximum)

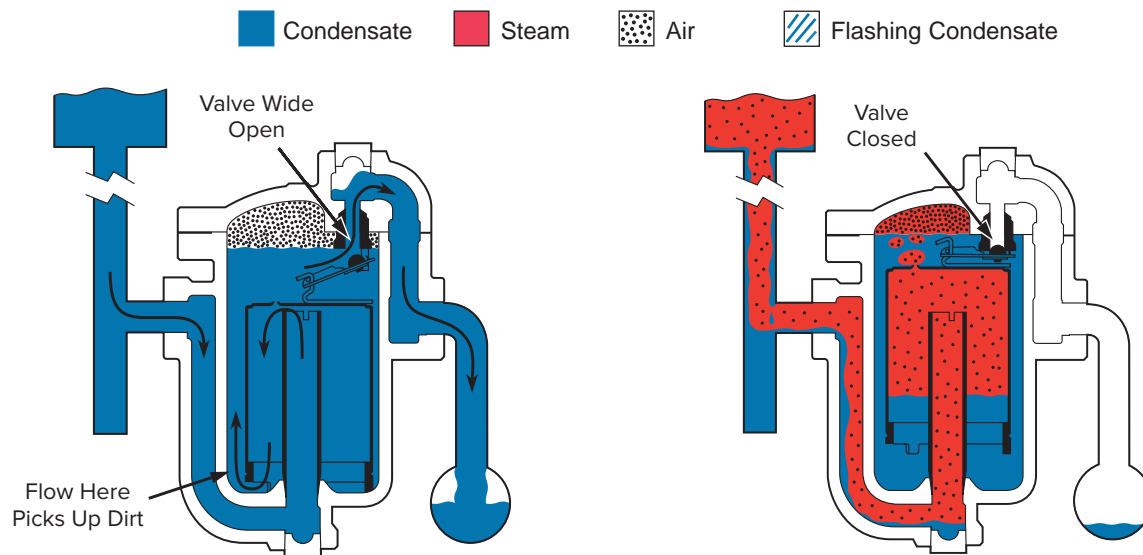

1. Steam trap is installed in drain line between steam-heated unit and condensate return header. On start-up, bucket is down and valve is wide open. As initial flood of condensate enters the trap and flows under bottom of bucket, it fills trap body and completely submerges bucket. Condensate then discharges through wide-open valve to return header.

2. Steam also enters trap under bottom of bucket, where it rises and collects at top, imparting buoyancy. Bucket then rises and lifts valve toward its seat until valve is snapped tightly shut. Air and carbon dioxide continually pass through bucket vent and collect at top of trap. Any steam passing through vent is condensed by radiation from trap.

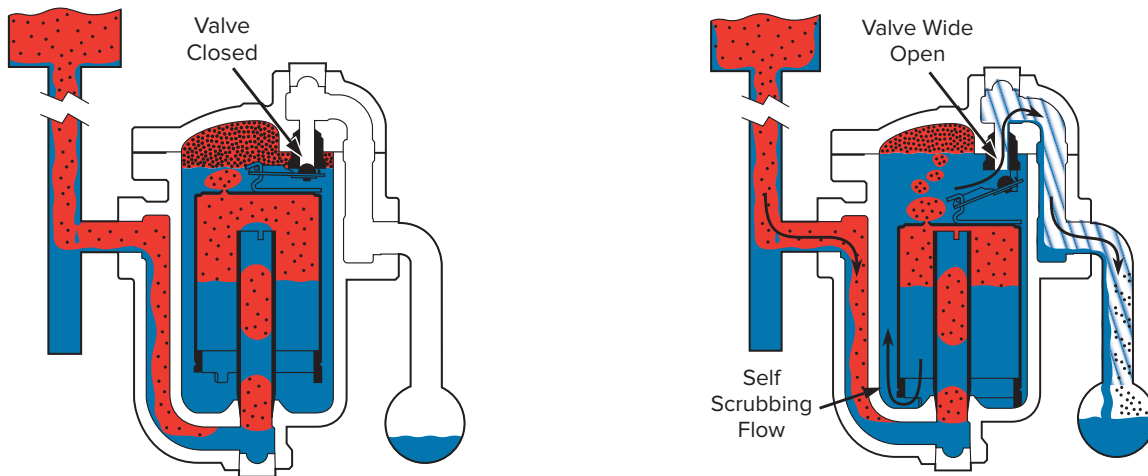

3. As the entering condensate starts to fill the bucket, the bucket begins to exert a pull on the lever. As the condensate continues to rise, more force is exerted until there is enough to open the valve against the differential pressure.

4. As the valve starts to open, the pressure force across the valve is reduced. The bucket then sinks rapidly and fully opens the valve. Accumulated air is discharged first, followed by condensate. The flow under the bottom of the bucket picks up dirt and sweeps it out of the trap. Discharge continues until more steam floats the bucket, and the cycle repeats.

Types of Armstrong Inverted Bucket Traps Available to Meet Specific Requirements

The availability of inverted bucket traps in different body materials, piping configurations and other variables permits flexibility in applying the right trap to meet specific needs. See Table CG-4.

1. All-Stainless Steel Traps. Sealed, tamper-proof stainless steel bodies enable these traps to withstand freeze-ups without damage. They may be installed on tracer lines, outdoor drips and other services subject to freezing. For pressures to 650 psig and temperatures to 800°F.

2. Cast Iron Traps. Standard inverted bucket traps for general service at pressures to 250 psig and temperatures to 450°F. Offered with side connections, side connections with integral strainers and bottom inlet—top outlet connections.

3. Forged Steel Traps. Standard inverted bucket traps for high pressure, high temperature services (including superheated steam) to 2,700 psig at 1,050°F.

4. Cast Stainless Steel Traps. Standard inverted bucket traps for high capacity, corrosive service. Repairable. For pressures to 1000 psi, 400 series and temperatures to 506°F.

Table CG-4. Typical Design Parameters for Inverted Bucket Traps

Body and Cap Materials	Cast Iron	Stainless Steel	Forged Steel	Cast Steel	Cast Stainless Steel
Connections	1/2" thru 2-1/2"	3/8" thru 1"	1/2" thru 2"	1/2" thru 1"	1/2" thru 2"
Type Connections	Screwed	Screwed, Socketweld	Screwed, Socketweld or Flanged	Screwed, Socketweld or Flanged	Screwed, Socketweld or Flanged
Operating Pressure (psig)	0 thru 250	0 thru 650	0 thru 2,700	0 thru 600	0 thru 1000
Capacity (lbs/hr)	To 20,000	To 4,400	To 20,000	To 4,400	To 20,000

The Float and Thermostatic Steam Trap

The float and thermostatic trap is a mechanical trap that operates on both density and temperature principles. The float valve operates on the density principle: A lever connects the ball float to the valve and seat. Once condensate reaches a certain level in the trap the float rises, opening the orifice and draining condensate. A water seal formed by the condensate prevents live steam loss.

Since the discharge valve is under water, it is not capable of venting air and non-condensables. When the accumulation of air and non-condensable gases causes a significant temperature drop, a thermostatic air vent in the top of the trap discharges it. The thermostatic vent opens at a temperature a few degrees below saturation so it's able to handle a large volume of air—through an entirely separate orifice—but at a slightly reduced temperature.

Armstrong F&T traps provide high air-venting capacity, respond immediately to condensate and are suitable for both industrial and HVAC applications.

Reliable Operation on Modulating Steam Pressure

Modulating steam pressure means that the pressure in the heat exchange unit being drained can vary anywhere from the maximum steam supply pressure down to vacuum under certain conditions. Thus, under conditions of zero pressure, only the force of gravity is available to push condensate through a steam trap. Substantial amounts of air may also be liberated under these conditions of low steam pressure. The efficient operation of the F&T trap meets all of these specialized requirements.

High Back Pressure Operation

Back pressure has no adverse effect on float and thermostatic trap operation other than capacity reduction due to low differential. The trap will not fail to close and will not blow steam due to the high back pressure.

Body and Cap Materials	Cast Iron	Cast Steel
Connections	1/2" thru 3"	1/2" thru 3"
Type Connections	Screwed or Flanged	Screwed, Socketweld or Flanged
Operating Pressure (psig)	0 thru 250	0 thru 465
Capacity (lbs/hr)	To 208,000	To 280,000

Figure CG-12. Operation of the F&T Steam Trap

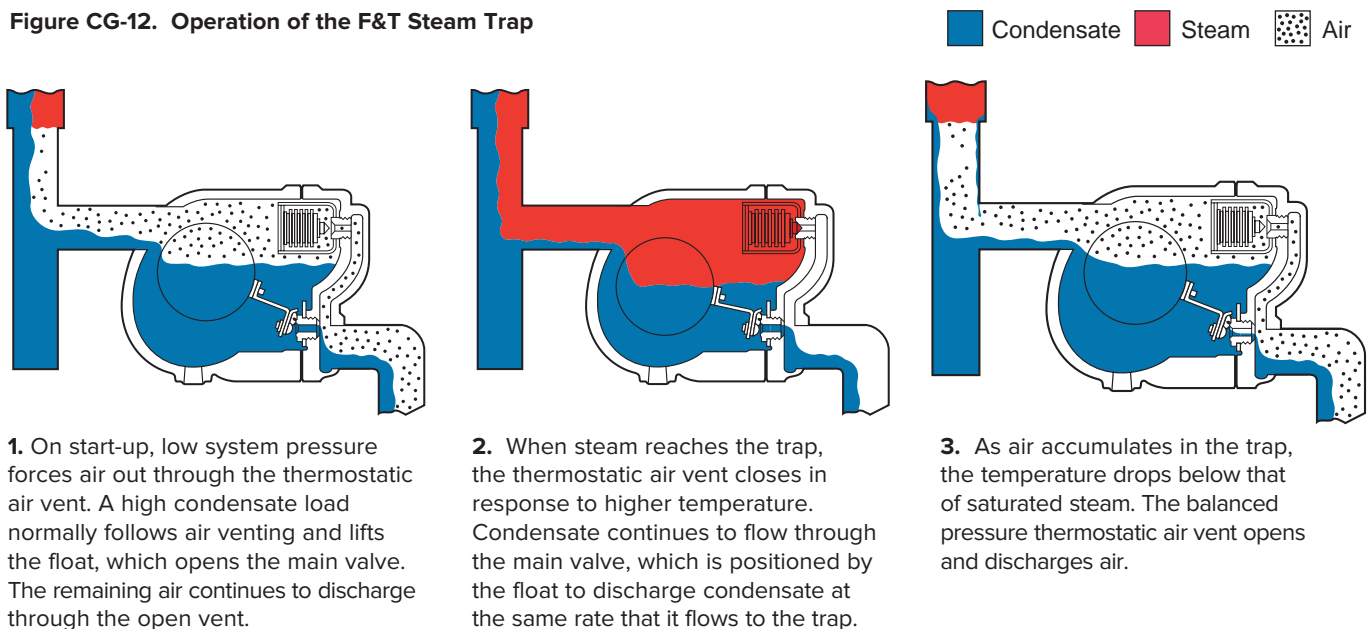

NOTE: These operational schematics of the F&T trap do not represent actual trap configuration.

The controlled disc steam trap is a time-delayed device that operates on the velocity principle. It contains only one moving part, the disc itself. Because it is very lightweight and compact, the CD trap meets the needs of many applications where space is limited. In addition to the disc trap's simplicity and small size, it also offers advantages such as resistance to hydraulic shock, the complete discharge of all condensate when open and intermittent operation for a steady purging action.

Operation of controlled disc traps depends on the changes in pressures in the chamber where the disc operates. The Armstrong CD trap will be open as long as cold condensate is flowing. When steam or flash steam reaches the inlet orifice, velocity of flow increases, pulling the disc toward the seat. Increasing pressure in the control chamber snaps the disc closed. The subsequent pressure reduction, necessary for the trap to open, is controlled by the heating chamber in the cap and a finite machined bleed groove in the disc. Once the system is up to temperature, the bleed groove controls the trap cycle rate.

Unique Heating Chamber

The unique heating chamber in Armstrong's controlled disc traps surrounds the disc body and control chamber. A controlled bleed from the chamber to the trap outlet controls the cycle rate. That means that the trap design—not ambient conditions—controls the cycle rate. Without this controlling feature, rain, snow and cold ambient conditions would upset the cycle rate of the trap.

Table CG-6. Typical Design Parameters for Controlled Disc Traps

Body and Cap Materials	Steel
Connections	3/8" thru 1"
Type Connections	Screwed, Socketweld or Flanged
Operating Pressure (psig)	10 thru 600
Capacity (lbs/hr)	To 2,850

Figure CG-13. Design and Operation of Controlled Disc Traps

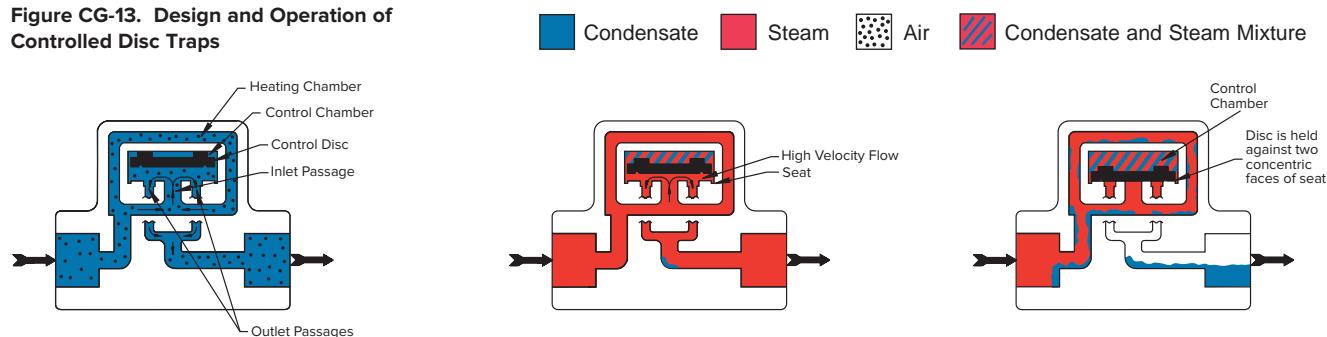

1. On start-up, condensate and air entering the trap pass through the heating chamber, around the control chamber and through the inlet orifice. This flow lifts the disc off the inlet orifice, and the condensate flows through to the outlet passages.

2. Steam enters through the inlet passage and flows under the control disc. The flow velocity across the face of the control disc increases, creating a low pressure that pulls the disc toward the seat.

3. The disc closes against two concentric faces of the seat, closing off the inlet passage and also trapping steam and condensate above the disc. There is a controlled bleeding of steam from the control chamber; flashing condensate helps maintain the pressure in the control chamber. When the pressure above the disc is reduced, the incoming pressure lifts the disc off the seat. If condensate is present, it will be discharged, and the cycle repeats.

The Bimetallic Steam Trap

Bimetallic steam traps have the ability to handle large start-up loads. As the trap increases in temperature, its stacked nickel-chrome bimetallic elements start to expand, allowing for tight shutoff as steam reaches the trap, thus preventing steam loss. In addition to its light weight and compact size, it offers resistance to water hammer. Titanium valve and seat on high-pressure bimetallic traps ensure extremely long service life in the harsh environment of superheated steam systems.

Table CG-7. Typical Design Parameters for Bimetallic Traps

Body and Cap Materials	Carbon Steel	Stainless Steel
Connection Sizes	1/2", 3/4", 1"	
Type Connections	Screwed, Socketweld, Flanged	Screwed, NPT, BSPT, Socketweld, Buttweld, Flanged
Operating (psig)	0 - 250	200 - 900
Cold Water Capacity lb/hr	up to 11,000	

Figure CG-14. Design and Operation of Bimetallic Steam Traps

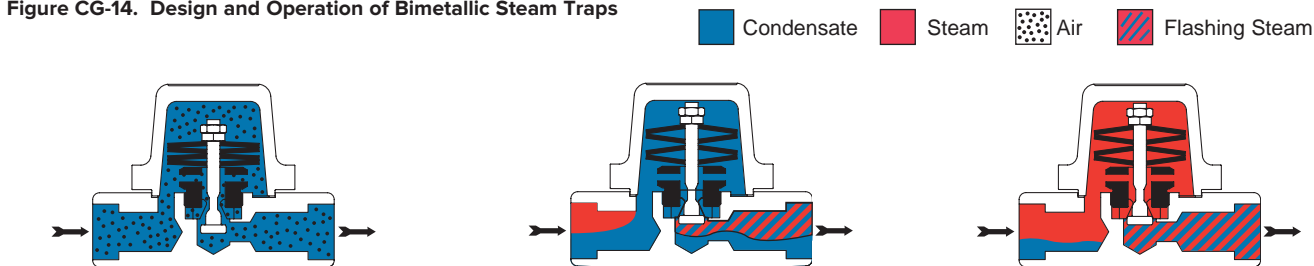

1. On start-up, the trap is cold, so the elements are flat and the valve is wide open, which results in air and condensate being easily removed from the system by working pressure.

2. With increasing temperature of the condensate, the bimetallic elements will start to expand and flex.

3. When set temperature is reached, the force of the elements is high enough to close the valve completely against the system pressure working on the valve.

Designs, materials, weights and performance ratings are approximate and subject to change without notice. Visit armstronginternational.com for up-to-date information.

The Thermostatic Steam Trap

Armstrong thermostatic steam traps are available with balanced pressure bellows or wafer-type elements and are constructed in a wide variety of materials, including stainless steel, carbon steel and bronze. These traps are used on applications with very light condensate loads.

Thermostatic Operation

Thermostatic steam traps operate on the difference in temperature between steam and cooled condensate and air. Steam increases the pressure inside the thermostatic element, causing the trap to close. As condensate and non-condensable gases back up in the cooling leg, the temperature begins to drop, and the thermostatic element contracts and opens the valve. The amount of condensate backed up ahead of the trap depends on the load conditions, steam pressure and size of the piping. It is important to note that an accumulation of non-condensable gases can occur behind the condensate backup.

NOTE: Thermostatic traps can also be used for venting air from a steam system. When air collects, the temperature drops and the thermostatic air vent automatically discharges the air at slightly below steam temperature throughout the entire operating pressure range.

	Balanced Pressure Bellows		Balanced Pressure Wafer		
	Stainless Steel	Bronze	Stainless Steel	Carbon Steel	Bronze
Body and Cap Materials	Stainless Steel	Bronze	Stainless Steel	Carbon Steel	Bronze
Connections	1/2", 3/4"	1/2", 3/4"	1/4" thru 1"	1/2", 3/4"	1/2", 3/4", 1"
Type Connections	Screwed, Socketweld	NPT Straight, Angle	Screwed, Socketweld	Screwed, Socketweld	NPT Straight, Angle
Operating Pressure (psig)	0 - 300	0 - 50	0 - 400	0 - 600	0 - 65
Capacity (lbs/hr)	To 3,450	To 1,600	To 70	To 85	To 960

Figure CG-15. Operation of the Thermostatic Steam Trap

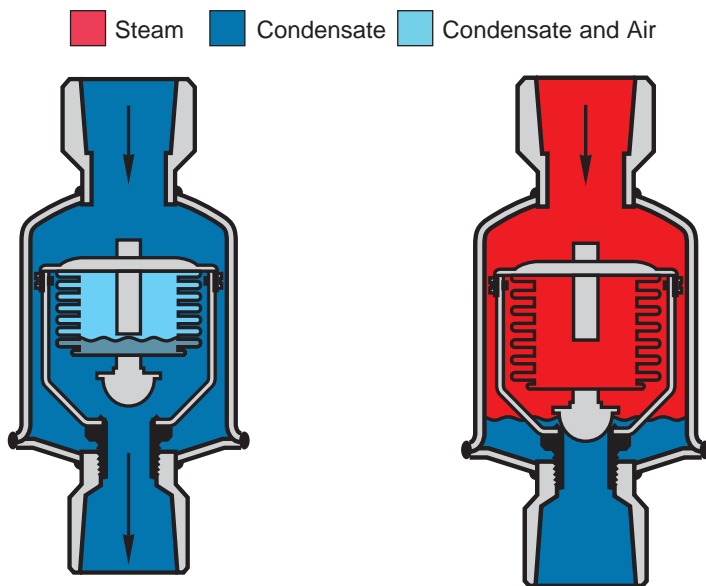

1. On start-up, condensate and air are pushed ahead of the steam directly through the trap. The thermostatic bellows element is fully contracted, and the valve remains wide open until steam approaches the trap.

2. As the temperature inside the trap increases, it quickly heats the charged bellows element, increasing the vapor pressure inside. When pressure inside the element becomes balanced with system pressure in the trap body, the spring effect of the bellows causes the element to expand, closing the valve. When temperature in the trap drops a few degrees below saturated steam temperature, imbalanced pressure contracts the bellows, opening the valve.

Figure CG-16. Operation of Thermostatic Wafer

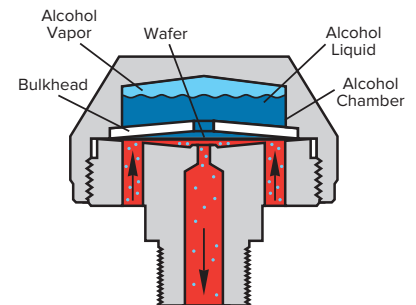

Balanced Pressure Thermostatic Wafer operation is very similar to balanced pressure bellows described in Fig. CG-15. The wafer is partially filled with a liquid. As the temperature inside the trap increases, it heats the charged wafer, increasing the vapor pressure inside. When the pressure inside the wafer exceeds the surrounding steam pressure, the wafer membrane is forced down on the valve seat, and the trap is closed. A temperature drop caused by condensate or non-condensable gases cools and reduces the pressure inside the wafer, allowing the wafer to uncover the seat.

Armstrong automatic differential condensate controllers (DC) are designed to function on applications where condensate must be lifted from a drain point or in gravity drainage applications where increased velocity will aid in drainage.

Lifting condensate from the drain point—often referred to as syphon drainage—reduces the pressure of condensate, causing a portion of it to flash into steam. Since ordinary steam traps are unable to distinguish flash steam and live steam, they close and impede drainage.

Increased velocity with gravity drainage will aid in drawing the condensate and air to the DC. An internal steam by-pass controlled by a manual metering valve causes this increased velocity. Therefore, the condensate controller automatically vents the by-pass or secondary steam. This is then collected for use in other heat exchangers or discharged to the condensate return line.

Capacity considerations for draining equipment vary greatly according to the application. However, a single condensate controller provides sufficient capacity for most applications.

Figure CG-17.

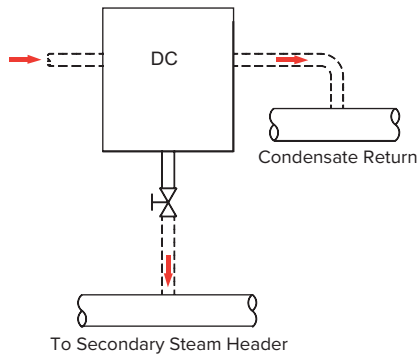

For the most efficient use of steam energy, Armstrong recommends this piping arrangement when secondary steam is collected and reused in heat transfer equipment.

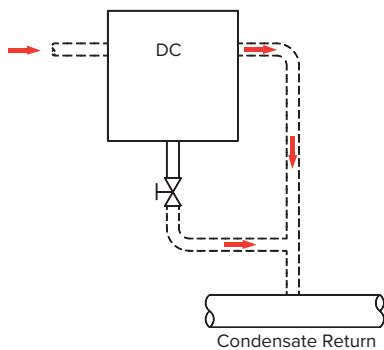

Piping arrangement when flash steam and non-condensables are to be removed and discharged directly to the condensate return line.

Condensate Controller Operation

Condensate, air and steam (live and flash) enter through the controller inlet. At this point flash steam and air are automatically separated from the condensate. Then they divert into the integral by-pass at a controlled rate, forming secondary steam (See Fig. CG-18).

The valve is adjustable so it matches the amount of flash present under full capacity operation or to meet the velocity requirements of the system. The condensate discharges through a separate orifice controlled by the inverted bucket.

Because of the dual orifice design, there is a preset controlled pressure differential for the secondary steam system, while maximum pressure differential is available to discharge the condensate.

Table CG-9. Typical Design Parameters for the Automatic Differential Condensate Controller

Body and Cap Materials	Cast Iron	Steel
Connections	1/2" thru 2"	1" thru 2"
Type Connections	Screwed	Screwed
Operating Pressure (psig)	0 thru 250	0 thru 650
Capacity (lbs/hr)	To 20,000	To 20,000

Figure CG-18. Condensate Controller Operation

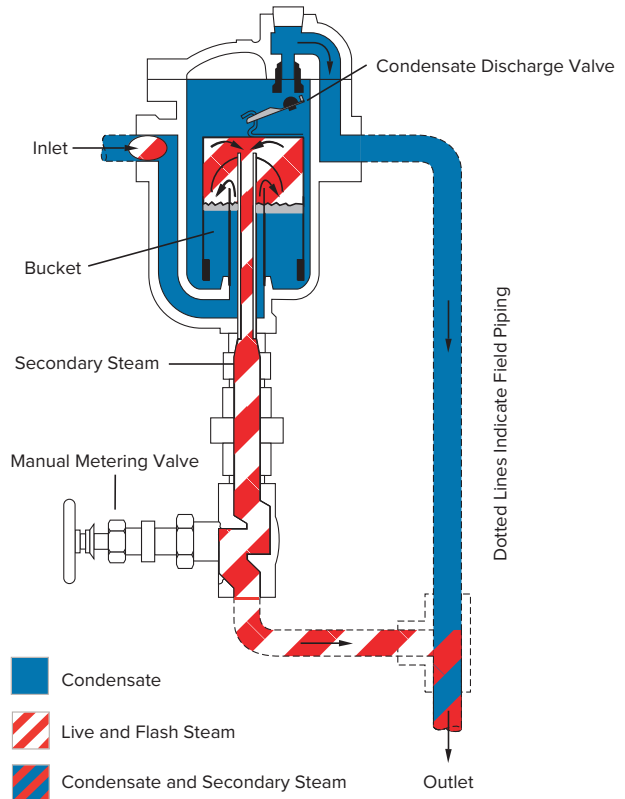

Steam Trap Selection

To obtain the full benefits from the traps described in the preceding section, it is essential to select traps of the correct size and pressure for a given job and to install and maintain them properly. One of the purposes of this section is to supply the information to make that possible. Actual installation and operation of steam trapping equipment should be performed only by experienced personnel. Selection or installation should always be accompanied by competent technical assistance or advice. This section should never be used as a substitute for such technical advice or assistance. We encourage you to contact Armstrong or its local representative for further details.

Basic Considerations

Unit trapping is the use of a separate steam trap on each steam-condensing unit including, whenever possible, each separate chest or coil of a single machine. The discussion under the Short Circuiting heading explains the “why” of unit trapping versus group trapping.

Rely on experience. Select traps with the aid of experience—either yours, the know-how of your Armstrong Representative or what others have learned in trapping similar equipment.

Do-it-yourself sizing. Do-it-yourself sizing is simple with the aid of Steam-A-ware, Armstrong’s sizing and selection software program, which can be downloaded at: armstronginternational.com.

Even without this computer program, you can easily size steam traps when you know or can calculate:

1. Condensate loads in lbs/hr
2. The safety factor to use
3. Pressure differential
4. Maximum allowable pressure

1. **Condensate load.** Each “How To” portion of this section contains formulas and useful information on steam condensing rates and proper sizing procedures.
2. **Safety factor or experience factor to use.** Users have found that they must generally use a safety factor in sizing steam traps. For example, a coil condensing 500 lbs/hr might require a trap that could handle up to 1,500 lbs/hr for best overall performance. This 3:1 safety factor takes care of varying condensate rates, occasional drops in pressure differential and system design factors.

Safety factors will vary from a low of 1.5:1 to a high of 10:1. The safety factors in this book are based on years of user experience.

Configuration affects safety factor. More important than ordinary load and pressure changes is the design of the steam-heated unit itself. Refer to Figs. CG-21, CG-22 and CG-23 showing three condensing units each producing 500 pounds of condensate per hour, but with safety factors of 2:1, 3:1 and 8:1.

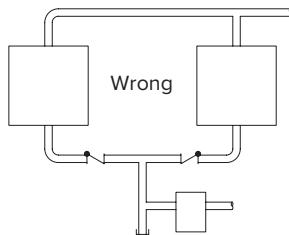

Figure CG-19. Two steam-consuming units drained by a single trap, referred to as group trapping, may result in short circuiting.

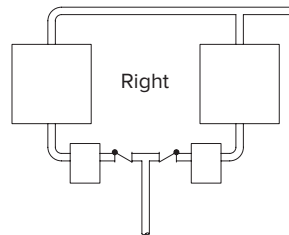

Figure CG-20. Short circuiting is impossible when each unit is drained by its own trap. Higher efficiency is assured.

Short Circuiting

If a single trap connects more than one drain point, condensate and air from one or more of the units may fail to reach the trap. Any difference in condensing rates will result in a difference in the steam pressure drop. A pressure drop difference too small to register on a pressure gauge is enough to let steam from the higher pressure unit block the flow of air or condensate from the lower pressure unit. The net result is reduced heating, output and fuel waste (see Figs. CG-19 and CG-20).

Identical Condensing Rates, Identical Pressures With Differing Safety Factors

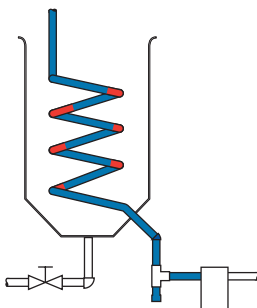

Figure CG-21. Continuous coil, constant pressure gravity flow to trap. 500 lbs/hr of condensate from a single copper coil at 30 psig. Gravity drainage to trap. Volume of steam space very small. 2:1 safety factor.

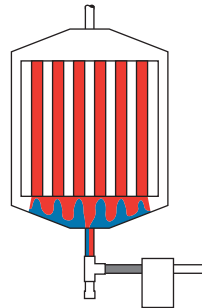

Figure CG-22. Multiple pipes, modulated pressure gravity flow to trap. 500 lbs/hr of condensate from unit heater at 80 psig. Multiple tubes create minor short-circuiting hazard. Use 3:1 safety factor at 40 psig.

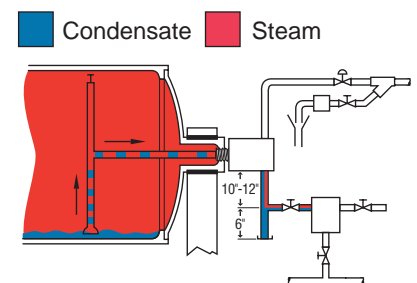

Figure CG-23. Large cylinder, syphon drained. 500 lbs/hr from a 4' diameter, 10' long cylinder dryer with 115 cu ft of space at 30 psig. The safety factor is 3:1 with a DC and 8:1 with an IB.

Designs, materials, weights and performance ratings are approximate and subject to change without notice. Visit armstronginternational.com for up-to-date information.

Economical steam trap/orifice selection. While an adequate safety factor is needed for best performance, too large a factor causes problems. In addition to higher costs for the trap and its installation, a needlessly oversized trap wears out more quickly. And in the event of a trap failure, an oversized trap loses more steam, which can cause water hammer and high back pressure in the return system.

3. Pressure differential. Maximum differential is the difference between boiler or steam main pressure or the downstream pressure of a PRV and return line pressure. See Fig. CG-24. The trap must be able to open against this pressure differential.

NOTE: Because of flashing condensate in the return lines, don't assume a decrease in pressure differential due to static head when elevating.

Operating differential. When the plant is operating at capacity, the steam pressure at the trap inlet may be lower than steam main pressure. And the pressure in the condensate return header may go above atmospheric.

If the operating differential is at least 80% of the maximum differential, it is safe to use maximum differential in selecting traps.

Modulated control of the steam supply causes wide changes in pressure differential. The pressure in the unit drained may fall to atmospheric or even lower (vacuum). This does not prevent condensate drainage if the installation practices in this handbook are followed.

IMPORTANT: Be sure to read the discussion to the right, which deals with less common but important reductions in pressure differential.

4. Maximum allowable pressure. The trap must be able to withstand the maximum allowable pressure of the system or design pressure. It may not have to operate at this pressure, but it must be able to contain it. As an example, the maximum inlet pressure is 350 psig and the return line pressure is 150 psig. This results in a differential pressure of 200 psi; however, the trap must be able to withstand 350 psig maximum allowable pressure. See Fig. CG-24.

Factors Affecting Pressure Differential

Except for failures of pressure control valves, differential pressure usually varies on the low side of the normal or design value. Variations in either the inlet or discharge pressure can cause this.

Inlet pressure can be reduced below its normal value by:

1. A modulating control valve or temperature regulator.
2. "Syphon drainage." Every 2' of lift between the drainage point and the trap reduces the inlet pressure (and the differential) by one psi. See Fig. CG-25.

Discharge pressure can be increased above its normal value by:

1. Pipe friction.
2. Other traps discharging into a return system of limited capacity.
3. Elevating condensate. Every 2' of lift increases the discharge pressure (and the differential) by one psi when the discharge is only condensate. However, with flash present, the extra back pressure could be reduced to zero. See Fig. CG-26, noting the external check valve.

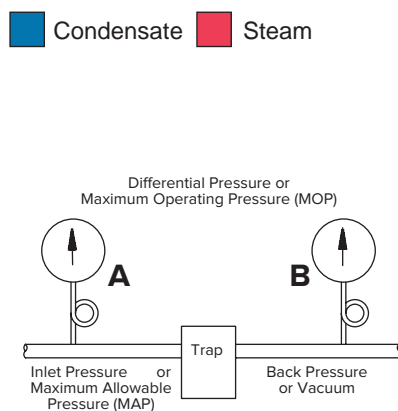

Figure CG-24. "A" minus "B" is Pressure Differential: If "B" is back pressure, subtract it from "A". If "B" is vacuum, add it to "A".

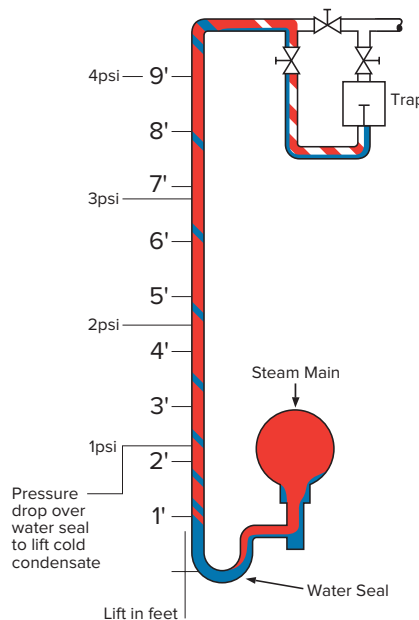

Figure CG-25. Condensate from gravity drain point is lifted to trap by a syphon. Every 2' of lift reduces pressure differential by 1 psi. Note seal at low point and the trap's internal check valve to prevent backflow.

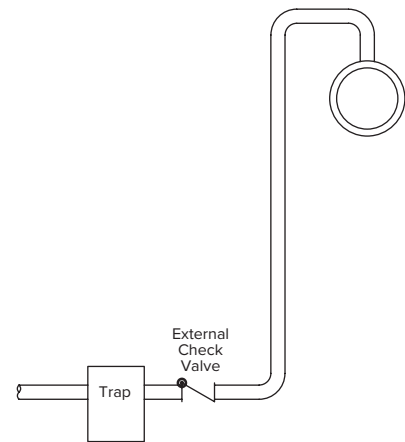

Figure CG-26. When trap valve opens, steam pressure will elevate condensate. Every 2' of lift reduces pressure differential by 1 psi.

How to Trap Steam Distribution Systems

Steam distribution systems link boilers and the equipment actually using steam, transporting it to any location in the plant where its heat energy is needed.

The three primary components of steam distribution systems are boiler headers, steam mains and branch lines. Each fulfills certain requirements of the system and, together with steam separators and steam traps, contributes to efficient steam use.

Drip legs. Common to all steam distribution systems is the need for drip legs at various intervals (Fig. CG-27). These are provided to:

1. Let condensate escape by gravity from the fast-moving steam.
2. Store the condensate until the pressure differential can discharge it through the steam trap.

Figure CG-27. Drip Leg Sizing

The properly sized drip leg will capture condensate. Too small a drip leg can actually cause a venturi “piccolo” effect where pressure drop pulls condensate out of the trap. See Table CG-13 on page CG-21.

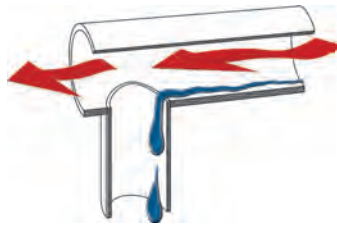

Chart CG-6. Recommendation Chart
(See Page CG-4 for “Feature Code” References.)

Equipment Being Trapped	1st Choice and Feature Code	Alternate Choice
Boiler Header	IBLV M, E, L, N, B, Q	*F&T

*On superheated steam never use an F&T type trap.
Always use an IB with internal check valve and burnished valve and seat.

Chart CG-7. Recommendation Chart

Equipment Being Trapped	1st Choice, Feature Code and Alternate Choice(s)	0 - 30 psig	Above 30 psig
Steam Mains and Branch Lines Non-freezing Conditions	B, M, N, L, F, E, C, D, Q	*IB	*IB
	Alternate Choice	F&T	**F&T
Steam Mains and Branch Lines Freezing Conditions	B, C, D, E, F, L, M, N, Q, J	*IB	*IB
	Alternate Choice	Thermostatic or CD	

*Provide internal check valve when pressures fluctuate.
**Use IBLV above F&T pressure/temperature limitations.
NOTE: On superheated steam, use an IB with internal check valve and burnished valve and seat.

Boiler Headers

A boiler header is a specialized type of steam main that can receive steam from one or more boilers. It is most often a horizontal line which is fed from the top and in turn feeds the steam mains. It is important to trap the boiler header properly to assure that any carryover (boiler water and solids) is removed before distribution into the system.

Steam traps that serve the header must be capable of discharging large slugs of carryover as soon as they are present. Resistance to hydraulic shock is also a consideration in the selection of traps.

Trap selection and safety factor for boiler headers (saturated steam only). A 1.5:1 safety factor is recommended for virtually all boiler header applications. The required trap capacity can be obtained by using the following formula: Required Trap Capacity = Safety Factor x Load Connected to Boiler(s) x Anticipated Carryover (typically 10%).

EXAMPLE: What size steam trap will be required on a connected load of 50,000 lbs/hr with an anticipated carryover of 10%? Using the formula:
Required Trap Capacity = 1.5 x 50,000 x 0.10 = 7,500 lbs/hr.

The ability to respond immediately to slugs of condensate, excellent resistance to hydraulic shock, dirt-handling ability and efficient operation on very light loads are features that make the inverted bucket the most suitable steam trap for this application.

Installation. If steam flow through the header is in one direction only, a single steam trap is sufficient at the downstream end. With a midpoint feed to the header (Fig. CG-28), or a similar two-directional steam flow arrangement, each end of the boiler header should be trapped.

Figure CG-28. Boiler Headers

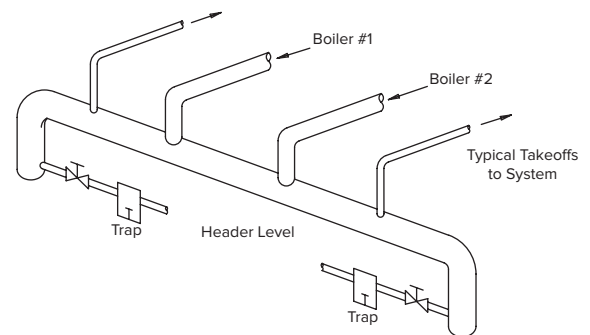

Drip leg same as the header diameter up to 4"
Above 4", 1/2 header size, but never less than 4"

Steam Mains

One of the most common uses of steam traps is the trapping of steam mains. These lines need to be kept free of air and condensate in order to keep steam-using equipment operating properly. Inadequate trapping on steam mains often leads to water hammer and slugs of condensate that can damage control valves and other equipment.

There are two methods used for the warm-up of steam mains—supervised and automatic. Supervised warm-up is widely used for initial heating of large-diameter and/or long mains. The suggested method is for drip valves to be opened wide for free blow to the atmosphere before steam is admitted to the main. These drip valves are not closed until all or most of the warm-up condensate has been discharged. Then the traps take over the job of removing condensate that may form under operating conditions. Warm-up of principal piping in a power plant will follow much the same procedure.

Automatic warm-up is when the boiler is fired, allowing the mains and some or all equipment to come up to pressure and temperature without manual help or supervision.

CAUTION: Regardless of warm-up method, allow sufficient time during the warm-up cycle to minimize thermal stress and prevent any damage to the system.

Trap selection and safety factor for steam mains (saturated steam only). Select trap to discharge condensate produced by radiation losses at running load. Sizing for start-up loads results in oversized traps, which may wear prematurely. Size drip legs to collect condensate during low-pressure, warm-up conditions. (See Table CG-13 on page CG-21.) Condensate loads of insulated pipe can be found in Table CG-10. All figures in the table assume the insulation to be 75% effective. For pressures or pipe sizes not included in the table, use the following formula:

$$C = \frac{A \times U \times (T_1 - T_2)E}{H}$$

Where:

- C = Condensate in lbs/hr-foot
- A = External area of pipe in square feet (Table CG-10, Col. 2)
- U = Btu/sq ft/degree temperature difference/hr from Chart CG-7 (page CG-19)
- T₁ = Steam temperature in °F
- T₂ = Air temperature in °F
- E = 1 minus efficiency of insulation (Example: 75% efficient insulation: 1 - .75 = .25 or E = .25)
- H = Latent heat of steam (See Steam Table on page CG-5)

Pressure, psig	15	30	60	125	180	250	450	600	900	
Pipe Size (in)	sq ft Per Lineal ft									
Pounds of Condensate Per Hour Per Lineal Foot										
1	.344	.05	.06	.07	.10	.12	.14	.186	.221	.289
1-1/4	.434	.06	.07	.09	.12	.14	.17	.231	.273	.359
1-1/2	.497	.07	.08	.10	.14	.16	.19	.261	.310	.406
2	.622	.08	.10	.13	.17	.20	.23	.320	.379	.498
2-1/2	.753	.10	.12	.15	.20	.24	.28	.384	.454	.596
3	.916	.12	.14	.18	.24	.28	.33	.460	.546	.714
3-1/2	1.047	.13	.16	.20	.27	.32	.38	.520	.617	.807
4	1.178	.15	.18	.22	.30	.36	.43	.578	.686	.897
5	1.456	.18	.22	.27	.37	.44	.51	.698	.826	1.078
6	1.735	.20	.25	.32	.44	.51	.59	.809	.959	1.253
8	2.260	.27	.32	.41	.55	.66	.76	1.051	1.244	1.628
10	2.810	.32	.39	.51	.68	.80	.94	1.301	1.542	2.019
12	3.340	.38	.46	.58	.80	.92	1.11	1.539	1.821	2.393
14	3.670	.42	.51	.65	.87	1.03	1.21	1.688	1.999	2.624
16	4.200	.47	.57	.74	.99	1.19	1.38	1.927	2.281	2.997
18	4.710	.53	.64	.85	1.11	1.31	1.53	2.151	2.550	3.351
20	5.250	.58	.71	.91	1.23	1.45	1.70	2.387	2.830	3.725
24	6.280	.68	.84	1.09	1.45	1.71	2.03	2.833	3.364	4.434

Pressure, psig	2	15	30	60	125	180	250	
Pipe Size (in)	wt of Pipe Per ft (lbs)							
Pounds of Condensate Per Lineal Foot								
1	1.69	.030	.037	.043	.051	.063	.071	.079
1-1/4	2.27	.040	.050	.057	.068	.085	.095	.106
1-1/2	2.72	.048	.059	.069	.082	.101	.114	.127
2	3.65	.065	.080	.092	.110	.136	.153	.171
2-1/2	5.79	.104	.126	.146	.174	.215	.262	.271
3	7.57	.133	.165	.190	.227	.282	.316	.354
3-1/2	9.11	.162	.198	.229	.273	.339	.381	.426
4	10.79	.190	.234	.271	.323	.400	.451	.505
5	14.62	.258	.352	.406	.439	.544	.612	.684
6	18.97	.335	.413	.476	.569	.705	.795	.882
8	28.55	.504	.320	.720	.860	1.060	1.190	1.340
10	40.48	.714	.880	1.020	1.210	1.500	1.690	1.890
12	53.60	.945	1.170	1.350	1.610	2.000	2.240	2.510
14	63.00	1.110	1.370	1.580	1.890	2.340	2.640	2.940
16	83.00	1.460	1.810	2.080	2.490	3.080	3.470	3.880
18	105.00	1.850	2.280	2.630	3.150	3.900	4.400	4.900
20	123.00	2.170	2.680	3.080	3.690	4.570	5.150	5.750
24	171.00	3.020	3.720	4.290	5.130	6.350	7.150	8.000

Pipe Size (in)	Schedule 40	Schedule 80	Schedule 160	XX Strong
1	1.69	2.17	2.85	3.66
1-1/4	2.27	3.00	3.76	5.21
1-1/2	2.72	3.63	4.86	6.41
2	3.65	5.02	7.45	9.03
2-1/2	5.79	7.66	10.01	13.69
3	7.57	10.25	14.32	18.58
3-1/2	9.11	12.51	-	22.85
4	10.79	14.98	22.60	27.54
5	14.62	20.78	32.96	38.55
6	18.97	28.57	45.30	53.16
8	28.55	43.39	74.70	72.42
10	40.48	54.74	116.00	-
12	53.60	88.60	161.00	-
14	63.00	107.00	190.00	-
16	83.00	137.00	245.00	-
18	105.00	171.00	309.00	-
20	123.00	209.00	379.00	-
24	171.00	297.00	542.00	-

How to Trap Steam Distribution Systems

For traps installed between the boiler and the end of the steam main, apply a 2:1 safety factor. Apply a 3:1 safety factor for traps installed at the end of the main or ahead of reducing and shutoff valves that are closed part of the time.

The inverted bucket trap is recommended because it can handle dirt and slugs of condensate and resists hydraulic shock. In addition, should an inverted bucket fail, it usually does so in the open position.

Installation. Both methods of warm-up use drip legs and traps at all low spots or natural drainage points such as:

- Ahead of risers
- End of mains
- Ahead of expansion joints or bends
- Ahead of valves or regulators

Chart CG-7. Btu Heat Loss Curves

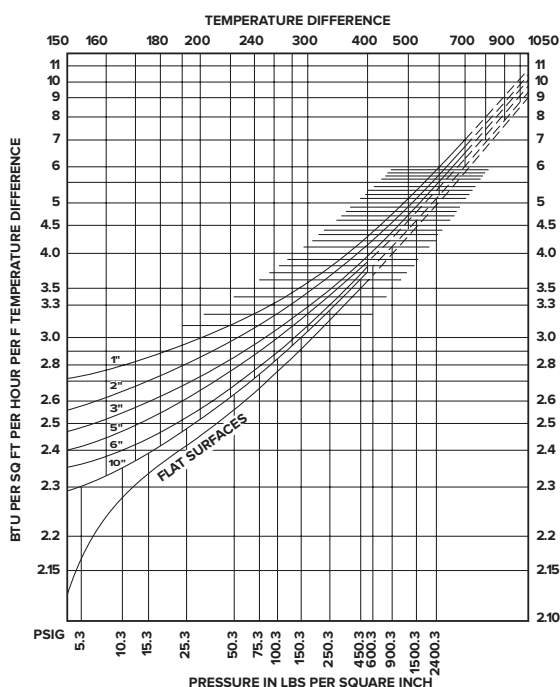

Install drip legs and drain traps even where there are no natural drainage points (See Figs. CG-29, CG-30 and CG-31). These should normally be installed at intervals of about 300' and never longer than 500'.

On a supervised warm-up, make drip leg length at least 1-1/2 times the diameter of the main, but never less than 10". Make drip legs on automatic warm-ups a minimum of 28" in length. For both methods, it is a good practice to use a drip leg the same diameter as the main up to 4" pipe size and at least 1/2 of the diameter of the main above that, but never less than 4". See Table CG-13.

Table CG-13. Recommended Steam Main and Branch Line Drip Leg Sizing			
M Steam Main Size (in)	D Drip Leg Diameter (in)	H Drip Leg Length Min. (in)	
		Supervised Warm-Up	Automatic Warm-Up
1/2	1/2	10	28
3/4	3/4	10	28
1	1	10	28
2	2	10	28
3	3	10	28
4	4	10	28
6	4	10	28
8	4	12	28
10	6	15	28
12	6	18	28
14	8	21	28
16	8	24	28
18	10	27	28
20	10	30	30
24	12	36	36

Chart CG-8. Recommendation Chart (See Page CG-4 for "Feature Code" References.)		
Equipment Being Trapped	1st Choice and Feature Code	Alternate Choice
Steam Separator	IBLV B, M, L, E, F, N, Q	*DC

*DC is 1st choice where steam quality is 90% or less.

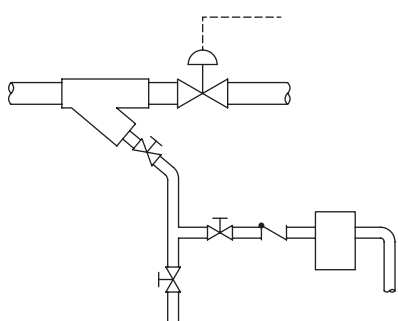

Figure CG-29.
Trap draining strainer ahead of PRV.

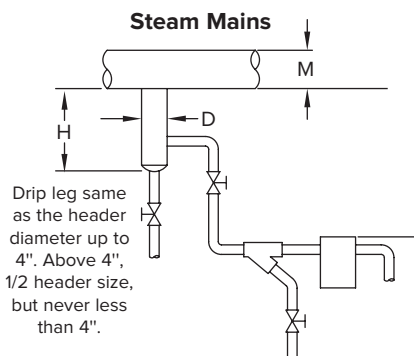

Figure CG-30.
Trap draining drip leg on main.

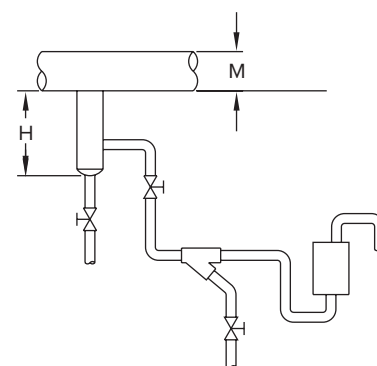

Figure CG-31.
Trap draining drip leg at riser. Distance "H" in inches ÷ 28 = psi static head for forcing water through the trap.

Branch Lines

Branch lines are take-offs from the steam mains supplying specific pieces of steam-using equipment. The entire system must be designed and hooked up to prevent accumulation of condensate at any point.

Trap selection and safety factor for branch lines. The formula for computing condensate load is the same as that used for steam mains. Branch lines also have a recommended safety factor of 3:1.

Installation. Recommended piping from the main to the control is shown in Fig. CG-32 for runouts under 10' and Fig. CG-33 for runouts over 10'. See Fig. CG-34 for piping when control valve must be below the main.

Install a full pipe-size strainer ahead of each control valve as well as ahead of the PRV, if used. Provide blowdown valves, preferably with IB traps. A few days after starting the system, examine the strainer screens to see if cleaning is necessary.

Separators

Steam separators are designed to remove any condensate that forms within steam distribution systems. They are most often used ahead of equipment where especially dry steam is essential. They are also common on secondary steam lines, which by their very nature have a large percentage of entrained condensate.

Important factors in trap selection for separators are the ability to handle slugs of condensate, provide good resistance to hydraulic shock and operate on light loads.

Trap selection and safety factors for separators. Apply a 3:1 safety factor in all cases, even though different types of traps are recommended, depending on condensate and pressure levels.

Use the following formula to obtain the required trap capacity:

Required trap capacity in lbs/hr = safety factor x steam flow rate in lbs/hr x anticipated percent of condensate (typically 10% to 20%).

EXAMPLE: What size steam trap will be required on a flow rate of 10,000 lbs/hr? Using the formula:

Required trap capacity =
 $3 \times 10,000 \times 0.10 = 3,000 \text{ lbs/hr.}$

The inverted bucket trap with large vent is recommended for separators. When dirt and hydraulic shock are not significant problems, an F&T type trap is an acceptable alternative.

An automatic differential condensate controller may be preferred in many cases. It combines the best features of both of the above and is recommended for large condensate loads that exceed the separating capability of the separator.

Installation

Connect traps to the separator drain line 10" to 12" below the separator with the drain pipe running the full size of the drain connection down to the trap take-off (Fig. CG-35). The drain pipe and dirt pocket should be the same size as the drain connection.

Branch Lines

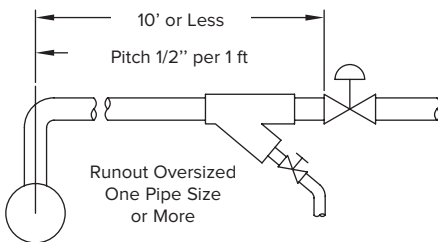

Figure CG-32. Piping for runout less than 10 ft. No trap required unless pitch back to supply header is less than 1/2" per ft.

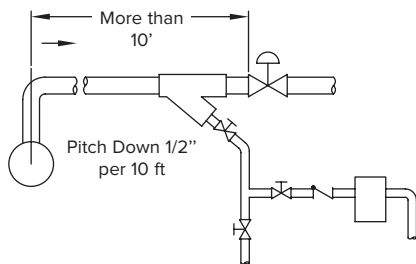

Figure CG-33. Piping for runout greater than 10'. Drip leg and trap required ahead of control valve. Strainer ahead of control valve can serve as drip leg if blowdown connection runs to an inverted bucket trap. This will also minimize the strainer cleaning problem. Trap should be equipped with an internal check valve or a swing check installed ahead of the trap.

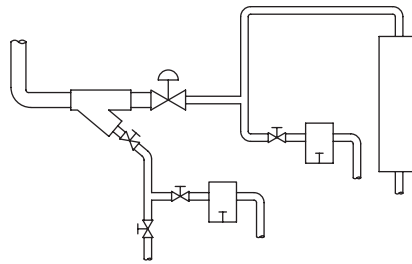

Figure CG-34. Regardless of the length of the runout, a drip leg and trap are required ahead of the control valve located below steam supply. If coil is above control valve, a trap should also be installed at downstream side of control valve.

Steam Separator

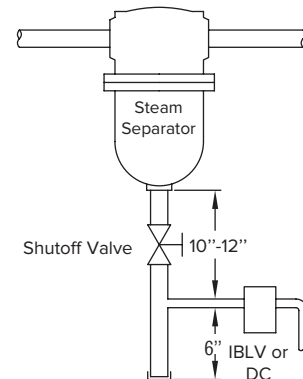

Figure CG-35. Drain downstream side of separator. Full-size drip leg and dirt pocket are required to ensure positive and fast flow of condensate to the trap.

How to Trap Steam Tracer Lines

Steam tracer lines are designed to maintain the fluid in a primary pipe at a certain uniform temperature. In most cases, these tracer lines are used outdoors, which makes ambient weather conditions a critical consideration.

The primary purpose of steam traps on tracer lines is to retain the steam until its latent heat is fully utilized and then discharge the condensate and non-condensable gases. As is true with any piece of heat transfer equipment, each tracer line should have its own trap. Even though multiple tracer lines may be installed on the same primary fluid line, unit trapping is required to prevent short circuiting. See page 17.

In selecting and sizing steam traps, it's important to consider their compatibility with the objectives of the system, as traps must:

1. Conserve energy by operating reliably over a long period of time.
2. Provide abrupt periodic discharge in order to purge the condensate and air from the line.
3. Operate under light load conditions.
4. Resist damage from freezing if the steam is shut off.

The cost of steam makes wasteful tracer lines an exorbitant overhead no industry can afford.

Trap Selection for Steam Tracer Lines.

The condensate load to be handled on a steam tracer line can be determined from the heat loss from the product pipe by using this formula:

$$Q = \frac{L \times U \times \Delta T \times E}{S \times H}$$

Where:

- Q = Condensate load, lbs/hr
- L = Length of product pipe between tracer line traps in ft
- U = Heat transfer factor in Btu/sq ft/°F/hr (from Chart CG-7, page 21)
- ΔT = Temperature differential in °F
- E = 1 minus efficiency of insulation (example: 75% efficient insulation or 1 - .75 = .25 or E = .25)
- S = Lineal feet of pipe line per sq ft of surface (from Table CG-29, page 55)
- H = Latent heat of steam in Btu/lb (from Steam Table, page 5)

Typical Tracer Installation

Figure CG-36.

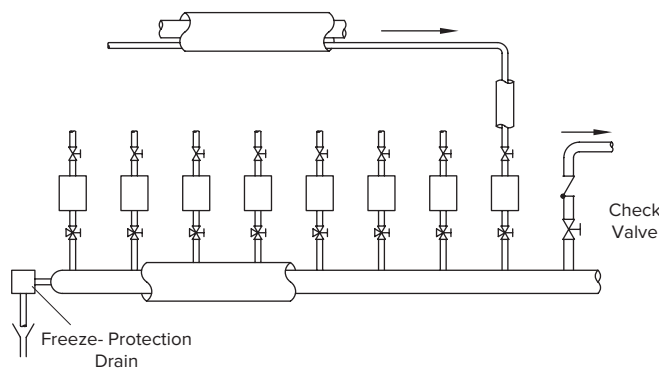

Figure CG-37.

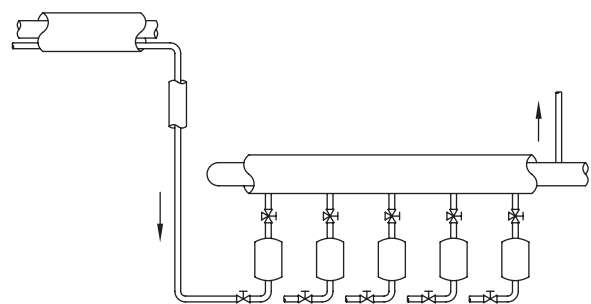

Chart CG-9. Recommendation Chart
(See Page CG-4 for "Feature Code" References.)

Equipment Being Trapped	1st Choice and Feature Code	Alternate Choice
Tracer Lines	*1B A, B, C, L, J, N, I, K	Thermostatic or CD

*Select a 5/64" steam trap orifice to conserve energy and avoid plugging with dirt and scale.

Table CG-14. Pipe Size Conversion Table (Divide lineal feet of pipe by factor given for size and type of pipe to get square feet of surface.)

Pipe Size (in)	Iron Pipe	Copper or Brass Pipe
1/2	4.55	7.63
3/4	3.64	5.09
1	2.90	3.82
1-1/4	2.30	3.05
1-1/2	2.01	2.55
2	1.61	1.91
2-1/2	1.33	1.52
3	1.09	1.27
4	.848	.954

EXAMPLE: Three tracer lines at 100 psig steam pressure are used on a 20" diameter, 100' long insulated pipe to maintain a temperature of 190°F with an outdoor design temperature of -10°F. Assume further that the pipe insulation is 75% efficient. What is the condensate load?

Using the formula:

$$Q = \frac{100 \text{ ft} \times 2.44 \text{ Btu/sq ft} \cdot \text{°F} \cdot \text{hr} \times 200\text{°F} \times .25}{0.191 \text{ lin ft/sq ft} \times 880 \text{ Btu/lb}} = 72 \text{ lbs/hr}$$

Now divide by three in order to get the load per tracer line — 24 lbs/hr.

On most tracer line applications, the flow to the steam trap is surprisingly low; therefore, the smallest trap is normally adequate. Based on its ability to conserve energy by operating reliably over a long period of time, handle light loads, resist freezing and purge the system, an inverted bucket trap is recommended for tracer line service.

Safety factor. Use a 2:1 safety factor whether exposure to ambient weather conditions is involved or not. Do not oversize steam traps or tracer lines. Select a 5/64" steam trap orifice to conserve energy and avoid plugging with dirt and scale.

Installation

Install distribution or supply lines at a height above the product lines requiring steam tracing. For the efficient drainage of condensate and purging of non-condensables, pitch tracer lines for gravity drainage and trap all low spots. This will also help avoid tracer line freezing. (See Figs. CG-36, CG-37 and CG-38.)

To conserve energy, return condensate to the boiler. Use vacuum breakers immediately ahead of the traps to ensure drainage on shutdown on gravity drain systems. Freeze-protection drains on trap discharge headers are suggested where freezing conditions prevail.

Figure CG-38. Typical Tracer Installation

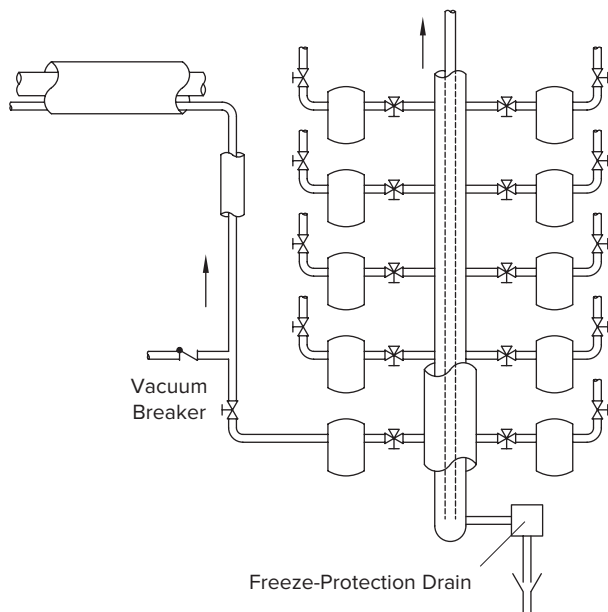
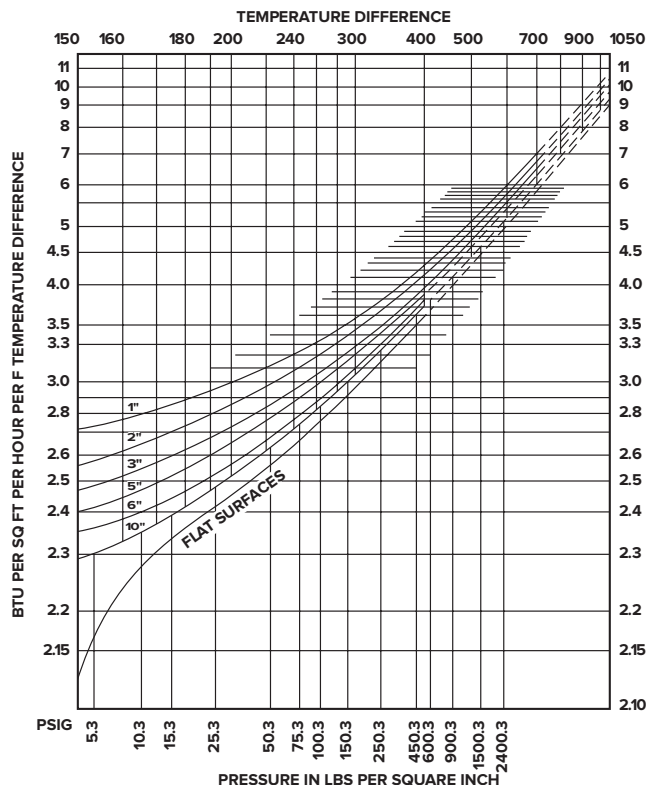

Chart CG-10. Btu Heat Loss Curves

Unit heat loss per sq ft of surface of uninsulated pipe of various diameters (also flat surface) in quiet air at 75°F for various saturated steam pressures or temperature differences.



How to Trap Superheated Steam Lines

At first glance, this may seem confusing due to the idea that superheated steam produces no condensate; therefore, the steam lines carrying superheated steam should not have any condensate in them. This is true once the system is up to temperature and pressure, but condensate removal is necessary up to this point. This section will explain what superheated steam is and the applications for its use.

The specific heat of any substance (using Btu standards) is the quantity of heat required to raise the temperature of 1 pound by 1 degree F. With this definition, the specific heat of water is 1, and the specific heat of superheated steam varies according to temperature and pressure. Specific heat decreases as the temperature rises but increases as the pressure goes up.

Superheated steam is customarily made by the addition of an extra set of coils inside the boiler or in the exhaust area of the boiler so as to use the “waste” heat from the boiler. Or, by the addition of a superheat chamber somewhere after the boiler, attached to the steam main. A schematic diagram of a steam generator with a superheated section of coil is shown below.

Properties of Superheated Steam

Superheated steam has several properties that make it unsuitable as a heat energy exchange medium yet ideal for work and mass transfer. Unlike saturated steam, the pressure and temperature of superheated steam are independent. As superheat is formed at the same pressure as the saturated steam, the temperature and volume increase.

In high heat release boilers with relatively small drums, separation of steam from water is extremely difficult. The combination of the small volume of water in the drums and rapid load swings produces severe shrink and swell conditions in the drum, which promotes water carryover.

This water can be removed with separators and traps in the steam outlets, but they are not 100% efficient. In

applications where dry steam is a necessity, additional superheating coils are placed in the boiler furnace as convection passes. More heat is added to the steam to vaporize the water carryover, which adds a small amount of superheat to guarantee absolutely dry steam.

Because superheated steam can give up so little heat before it converts back to saturated steam, it is not a good heat-transfer medium. Some processes, such as power plants, require a dry heat in order to do work. Whatever the type of power unit, superheat helps reduce the amount of condensation when starting from cold. Superheat also increases the power output by delaying condensation during the expansion stages in the equipment. Having drier steam at the exhaust end will increase the life of turbine blades.

Superheated steam can lose heat without condensing whereas saturated steam cannot. Therefore, superheated steam can be transported through very long steam lines without losing sufficient heat to condense. This permits the delivery of dry steam throughout the entire steam system.

Why Trap Superheated Systems?

The primary reason for traps on superheat systems is the start-up load. It can be heavy because of the large size of the mains. On start-up, manual valves will most likely be used since time is available to open and to close the valves. This is known as supervised start-up. A second reason for steam traps is to handle emergencies such as superheater loss or by-pass, which might require operation on saturated steam. In these unscheduled events, there is no time available for manually opening valves; therefore, steam traps are a necessity.

These are the situations for which proper trap sizing is a must. Condensate must be removed as it forms in any steam system to keep efficiency high and to minimize damaging water hammer and erosion.

Figure CG-39. Steam Generator

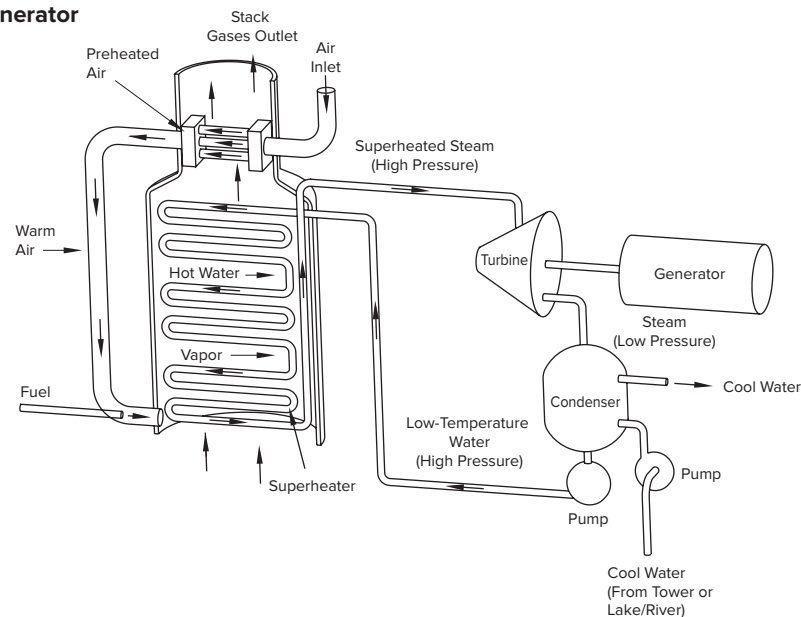

Sizing Superheat Loads to Traps

The condensate load to a trap used on superheat will vary widely from severe start-up loads to virtually no load during operation. Consequently, this is a demanding application for any steam trap.

During start-up, very large lines are being filled with steam from cold conditions. At this time, only saturated steam at low pressure is in the lines until the line temperature can be increased. This is done slowly over a long period so the lines are not stressed. Large condensate flow combined with low pressure is the start-up condition that requires the use of large capacity traps. These oversized traps are then required to operate at very high pressures with very low capacity requirements during normal superheat operation.

Typical start-up loads can be roughly calculated as follows:

Using:

$$C = \frac{0.114 W_p (t_2 - t_1)}{H}$$

Where:

- C = Amount of condensate in pounds
- W_p = Total weight of pipe (from Table CG-12 on page 20)
- H = Total heat of X pressure minus Sensible heat of Y Pressure (Latent heat of steam. For long warm-up times, use the total heat of saturated steam at the superheat steam supply pressure (X) minus the sensible heat of saturated steam at the average pressure (Y) during the warm-up time involved.)

0.114 = Specific heat of steel pipe in btu/lb °F

EXAMPLE:

Assuming a 100°F/hr (37°C/hr) heat-up
 14" (35 cm) diameter Schedule 80 line
 Supply superheated steam at 1200 psig 1070°F (85 bar, 577°C)
 Ambient temperature is 70°F (21°C)
 200 feet (61 m) of run between traps

For the first two hours:

$$W = (200 \text{ ft}) (107 \text{ lb/ft}) = 21,400 \text{ lb (9727 kg)}$$

$$t(2) - t(1) = 270 - 70 = 200^\circ\text{F (93}^\circ\text{C)}$$

$$H = 1184.8 \text{ btu/lb} - 196.27 \text{ btu/lb} = 988.5 \text{ btu/lb} = (474 \text{ kJ})$$

$$C = \frac{(0.114 \text{ btu/lb } ^\circ\text{F}) (21,400 \text{ lb}) (200^\circ\text{F})}{988.5 \text{ btu/lb}} = 493 \text{ lb (224 kg)}$$

For the second two hours:

The only thing that changes is the sensible heat of the saturated steam at average pressure during the time involved.

$$C = \frac{(0.114 \text{ btu/lb } ^\circ\text{F}) (21,400 \text{ lb}) (200^\circ\text{F})}{851.1 \text{ btu/lb}} = 573 \text{ lb (260 kg)}$$

Table CG-15. Time Period Table

Time Period	Average Pressure psig (barg)	Temperature at End of Time Period °F (°C)	14" Line Condensation Rate lb/hr (kg/hr)
1 st 2 hours	5 (.35)	270 (132)	247 (112)
2 nd 2 hours	140 (9.8)	470 (243)	286 (130)
3 rd 2 hours	700 (49)	670 (354)	352 (160)
4 th 2 hours	1200 (85)	870 (465)	288 (131)
5 th 2 hours	1200 (85)	1070 (577)	260 (118)

NOTE: For the average pressure of 1,200 psig (85 bar), assume H to be the latent heat of 1,200 psig (85 bar) steam plus superheat at temperature at the end of the period.

To ensure the condensate is removed efficiently, proper drip leg sizing and piping recommendations should also be followed when installing traps on superheat systems. The Table CG-13 on page 21 lists the proper drip leg size for given pipe sizes.

The question arises whether insulation should be used on the drip leg, piping leading to the trap, and the trap. The answer is no; unless it is mandatory for safety reasons, this section of the steam system should not be insulated. This ensures that some condensate is continuously being formed ahead of the trap and going to it, thus prolonging the trap's life.

Types of Superheat Traps

Bimetallic

A bimetallic trap is set to not open until condensate has cooled to a temperature below saturation. For the existing pressure, it will remain closed whenever steam of any temperature is in the trap. As the steam temperature rises, the pull of the bimetallic element becomes greater, providing a greater sealing force on the valve. Superheated steam tends to seal the valve better. The bimetallic trap also has the ability to handle large start-up loads. For these reasons, this trap is a good choice for superheat.

During superheat operation, the condensate in the trap must cool to a temperature below the saturation temperature before the trap can open. Condensate may back up into the line and cause damage to the lines, valves and equipment if drip leg size and length before the trap are insufficient.

Inverted Bucket

A water seal prevents steam from getting to the valve, promoting no live steam loss and long life. The valve at the top makes it impervious to dirt and permits removal of air. Large start-up loads can be handled, and the trap can still accommodate small running loads. There are problems associated with its application on superheat, mostly associated with the necessity of maintaining its water seal or "prime." Proper piping is necessary to maintain a prime in the IB.

For proper inverted bucket piping on superheat, refer to Figure CG-31 on page 21. When sizing a superheat trap, size for start-up load with no safety factor. Body materials should be selected on the basis of maximum pressure and temperature, including superheat.

How to Trap Space Heating Equipment

Space heating equipment such as unit heaters, air handling units, finned radiation and pipe coils is found in virtually all industries. This type of equipment is quite basic and should require very little routine maintenance. Consequently, the steam traps are usually neglected for long periods of time. One of the problems resulting from such neglect is residual condensate in the heating coil, which can cause damage due to freezing, corrosion and water hammer.

Trap Selection and Safety Factors

Different application requirements involving constant or variable steam pressure determine which type and size of trap should be used. There are two standard methods for sizing traps for coils.

1. Constant Steam Pressure.

INVERTED BUCKET TRAPS AND F&T TRAPS—Use a 3:1 safety factor at operating pressure differentials.

2. Modulating Steam Pressure.

F&T TRAPS AND INVERTED BUCKET TRAPS WITH THERMIC BUCKETS

- 0-15 psig steam—2:1 safety factor at 1/2 psi pressure differential
- 16-30 psig steam—2:1 at 2 psi pressure differential
- Above 30 psig steam—3:1 at 1/2 of maximum pressure differential across the trap.

INVERTED BUCKET TRAPS WITHOUT THERMIC BUCKETS
Above 30 psig steam pressure only—3:1 at 1/2 of maximum pressure differential across the trap.

Trap Selection for Unit Heaters and Air Handling Units

You may use three methods to compute the amount of condensate to be handled. Known operating conditions will determine which method to use.

1. **Btu method.** The standard rating for unit heaters and other air coils is Btu output with 2 psig steam pressure in the heater and entering air temperature of 60°F. To convert from standard to actual rating, use the conversion factors in Table CG-16 (page 29). Once the actual operating conditions are known, multiply the condensate load by the proper safety factor.

2. **CFM and air temperature rise method.** If you know only CFM capacity of fan and air temperature rise, find the actual Btu output by using this simple formula:
Btu/hr = CFM x 1.08 x temperature rise in °F.

EXAMPLE: What size trap will drain a 3,500 CFM heater that produces an 80°F temperature rise? Steam pressure is constant at 60 psig.

Using the formula:

$$3,500 \times 1.08 \times 80 = 302,400 \text{ Btu/hr.}$$

Now divide 302,400 Btu/hr by 904.5 Btu (from the Steam Tables) to obtain 334 lbs/hr and then multiply by the recommended safety factor 3. The application needs a trap with a 1,002 lbs/hr capacity.

Derive the 1.08 factor in the above formula as follows:

$$1 \text{ CFM} \times 60 = 60 \text{ CFH}$$

$$60 \text{ CFH} \times .075 \text{ lbs of air/cu ft} = 4.5 \text{ lbs of air/hr}$$

$$4.5 \times 0.24 \text{ Btu/lb } ^\circ\text{F (specific heat of air)} = 1.08 \text{ Btu/hr } ^\circ\text{F} - \text{CFM.}$$

3. Condensate method.

Once you determine Btu output:

- a. Divide Btu output by latent heat of steam at steam pressure used. See Column 2 of Table CG-16 (page 29) or the Steam Table (page 5). This will give the actual weight of steam condensed. For a close approximation, a rule of thumb could be applied in which the Btu output is simply divided by 1,000.
- b. Multiply the actual weight of steam condensing by the safety factor to get the continuous trap discharge capacity required.

Chart CG-11. Multipliers for Sizing Traps for Multiple Coils

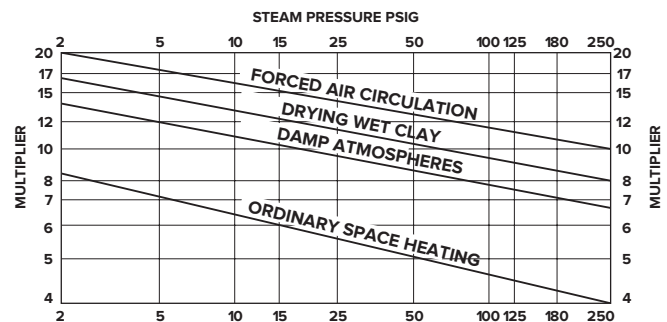

Chart CG-12. Recommendation Chart

(See Page 4 for "Feature Code" References.)

Equipment Being Trapped	1st Choice and Feature Code	Constant Pressure		1st Choice and Feature Code	Variable Pressure	
		0-30 psig	Above 30 psig		0-30 psig	Above 30 psig
Unit Heaters	B, C, E, K, N	IBLV	IBLV	B, C, G, H, L	F&T	*F&T
	Alternate Choice	F&T	*F&T	Alternate Choice	IBLV	IBLV
Air Handling Units	B, C, E, K, N, O	IBLV	IBLV	B, C, G, H, L	F&T	*F&T
	Alternate Choice	F&T	*F&T	Alternate Choice	IBT	IBLV
Finned Radiation & Pipe Coils	B, C, E, K, N	IBLV	IBLV	B, C, G, H, L	F&T	F&T
	Alternate Choice	Thermostatic	Thermostatic	Alternate Choice	IBLV	IBLV

*Use IBLV above F&T pressure/temperature limitations.

- PLEASE NOTE:
1. Provide vacuum breaker wherever subatmospheric pressures occur.
 2. Do not use F&T traps on superheated steam.

Designs, materials, weights and performance ratings are approximate and subject to change without notice. Visit armstronginternational.com for up-to-date information.

Trap Selection for Pipe Coils and Finned Radiation

Pipe coils. Insofar as possible, trap each pipe individually to avoid short circuiting.

Single pipe coils. To size traps for single pipes or individually trapped pipes, find the condensing rate per linear foot in Table CG-18 (page 29). Multiply the condensing rate per linear foot by the length in feet to get the normal condensate load.

For quick heating, apply a trap selection safety factor of 3:1 and use an inverted bucket trap with a thermic vent bucket. Where quick heating is not required, use a trap selection safety factor of 2:1 and select a standard inverted bucket trap.

Multiple pipe coils. To size traps to drain coils consisting of multiple pipes, proceed as follows:

1. Multiply the lineal feet of pipe in the coil by the condensing rate given in Table CG-18. This gives normal condensate load.
2. From Chart CG-11 (page 27), find the multiplier for your service conditions.
3. Multiply normal condensate load by multiplier to get trap required continuous discharge capacity.

Note that the safety factor is included in the multiplier.

Finned radiation. When Btu output is not known, condensing rates can be computed from Tables CG-17 and 19 (page

29) with sufficient accuracy for trap selection purposes. To enter Table CG-19, observe size of pipe, size of fins, number of fins and material. Determine condensing rate per foot under standard conditions from Table CG-19. Convert to actual conditions with Table CG-17.

Safety factor recommendations are to:

1. Overcome the short circuiting hazard created by the multiple tubes of the heater.
2. Ensure adequate trap capacity under severe operating conditions. In extremely cold weather the entering air temperature is likely to be lower than calculated, and the increased demand for steam in all parts of the plant may result in lower steam pressures and higher return line pressures—all of which cut trap capacity.
3. Ensure the removal of air and other non-condensables.

WARNING: For low-pressure heating, use a safety factor at the actual pressure differential, not necessarily the steam supply pressure, remembering that the trap must also be able to function at the maximum pressure differential it will experience.

Installation

In general, follow the recommendations of the specific manufacturer. Figs. CG-40, CG-41, CG-42 and CG-43 represent the consensus of space heating manufacturers.

NOTE: For explanation of safety drain trap, see Fig. CG-66 (page 49).

Figure CG-40. Trapping and Venting Air Heat Coil

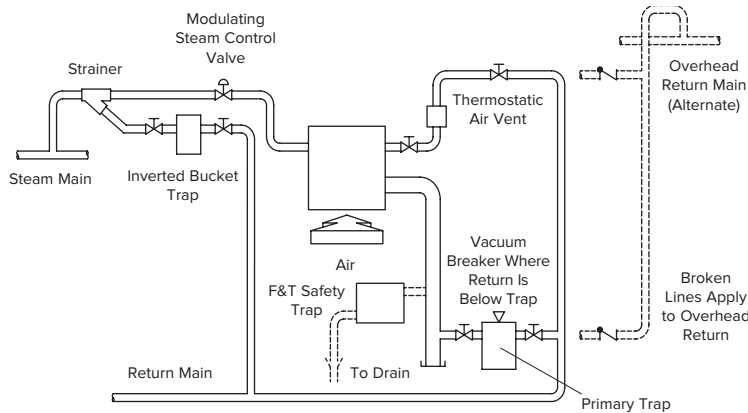

Figure CG-41. Trapping and Venting Air Heat Coil

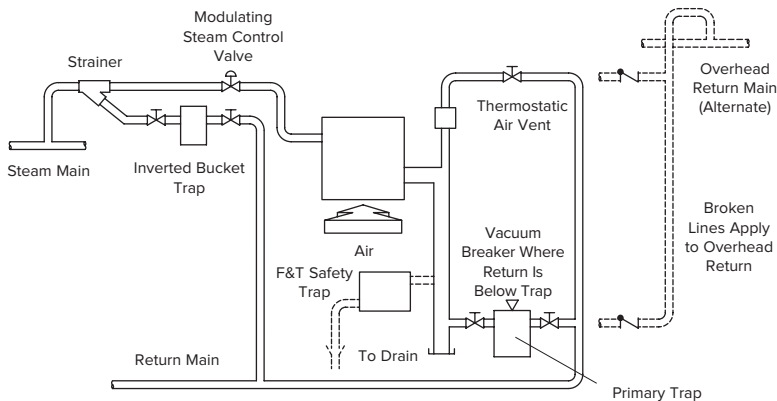

Figure CG-42. Generally approved method of piping and trapping high-pressure (above 15 psi) horizontal discharge heaters. Figs. CG-40 and CG-41 drip leg should be 10"-12" minimum.

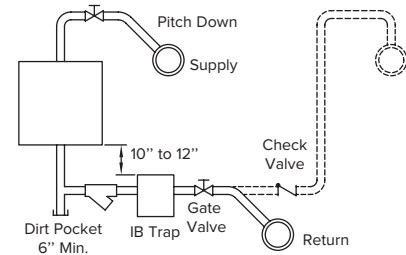

Figure CG-43. Generally approved method of piping and trapping low-pressure (under 15 psi) vertical discharge heaters.

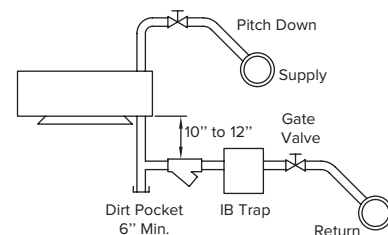

Table CG-16. A Table of Constants for determining the Btu output of a unit heater with conditions other than standard — standard being with 2 lbs steam pressure at 60°F entering air temperature. To apply, multiply the standard Btu capacity rating of heater by the indicated constant. (Reprinted from ASHRAE Guide by special permission.)

Steam Pressure lbs Per sq in	Latent Heat of Steam	Entering Air Temperature °F											
		-10	0	10	20	30	40	50	60	70	80	90	100
2	966.3	—	—	—	—	—	1.155	1.078	1.000	0.926	0.853	0.782	0.713
5	960.7	1.640	1.550	1.456	1.370	1.289	1.206	1.127	1.050	0.974	0.901	0.829	0.760
10	952.4	1.730	1.639	1.545	1.460	1.375	1.290	1.211	1.131	1.056	0.982	0.908	0.838
15	945.5	1.799	1.708	1.614	1.525	1.441	1.335	1.275	1.194	1.117	1.043	0.970	0.897
20	939.3	1.861	1.769	1.675	1.584	1.498	1.416	1.333	1.251	1.174	1.097	1.024	0.952
30	928.5	1.966	1.871	1.775	1.684	1.597	1.509	1.429	1.346	1.266	1.190	1.115	1.042
40	919.3	2.058	1.959	1.862	1.771	1.683	1.596	1.511	1.430	1.349	1.270	1.194	1.119
50	911.2	2.134	2.035	1.936	1.845	1.755	1.666	1.582	1.498	1.416	1.338	1.262	1.187
60	903.9	2.196	2.094	1.997	1.902	1.811	1.725	1.640	1.555	1.472	1.393	1.314	1.239
70	897.3	2.256	2.157	2.057	1.961	1.872	1.782	1.696	1.610	1.527	1.447	1.368	1.293
75	893.8	2.283	2.183	2.085	1.990	1.896	1.808	1.721	1.635	1.552	1.472	1.392	1.316
80	891.1	2.312	2.211	2.112	2.015	1.925	1.836	1.748	1.660	1.577	1.497	1.418	1.342
90	885.4	2.361	2.258	2.159	2.063	1.968	1.880	1.792	1.705	1.621	1.541	1.461	1.383
100	880.0	2.409	2.307	2.204	2.108	2.015	1.927	1.836	1.749	1.663	1.581	1.502	1.424

Table CG-17. Finned Radiation Conversion Factors for steam pressures and air temperatures other than 65°F air and 215°F steam.

Steam Pressure (psig)	Steam Temp. (°F)	Entering Air Temperature °F						
		45	55	65	70	75	80	90
.9	215.0	1.22	1.11	1.00	.95	.90	.84	.75
5	227.1	1.34	1.22	1.11	1.05	1.00	.95	.81
10	239.4	1.45	1.33	1.22	1.17	1.11	1.05	.91
15	249.8	1.55	1.43	1.31	1.26	1.20	1.14	1.00
30	274.0	1.78	1.66	1.54	1.48	1.42	1.37	1.21
60	307.3	2.10	2.00	1.87	1.81	1.75	1.69	1.51
100	337.9	2.43	2.31	2.18	2.11	2.05	2.00	1.81
125	352.9	2.59	2.47	2.33	2.27	2.21	2.16	1.96
175	377.4	2.86	2.74	2.60	2.54	2.47	2.41	2.21

Table CG-19. Finned Radiation Condensing Rates with 65°F air and 215°F steam (for trap selection purposes only).

	Pipe Size (in)	Fin Size (in)	Fins Per Inch	No. of Pipes High on 6" Centers	Condensate lbs/hr Per Foot of Pipe
Steel Pipe, Steel Fins Painted Black	1-1/4	3-1/4	3 to 4	1	1.1
				2	2.0
				3	2.6
	1-1/4	4-1/4	3 to 4	1	1.6
				2	2.4
				3	3.1
2	4-1/4	2 to 3	1	1.5	
			2	2.4	
			3	3.1	
Copper Pipe Aluminum Fins Unpainted	1-1/4	3-1/4	4	1	1.6
				2	2.2
				3	2.8
1-1/4	4-1/4	5	1	2.2	
			2	3.0	
			3	3.6	

Table CG-18. Condensing Rates in Bare Pipe Carrying Saturated Steam

Steam Pressure (psig)	Temp. Rise From 70°	Pounds of Condensate Per hr Per Lineal ft						
Pipe Size (in)	sq ft Per Lineal ft	15	30	60	125	180	250	
		180	204	237	283	310	336	
1/2	.220	.13	.15	.19	.26	.30	.35	
3/4	.275	.15	.19	.24	.33	.38	.45	
1	.344	.19	.23	.28	.39	.46	.54	
1-1/4	.434	.23	.28	.36	.49	.57	.67	
1-1/2	.497	.26	.32	.41	.55	.65	.76	
2	.622	.33	.40	.50	.68	.80	.93	
2-1/2	.753	.39	.47	.59	.81	.95	1.11	
3	.916	.46	.56	.70	.96	1.13	1.31	
3-1/2	1.047	.52	.63	.80	1.08	1.27	1.50	
4	1.178	.58	.70	.89	1.21	1.43	1.72	

Process air heaters are used for drying paper, lumber, milk, starch and other products as well as preheating combustion air for boilers.

Common examples of this type of equipment are process dryers, tunnel dryers, and combustion air preheaters. Compared with air heaters for space heating, process air heaters operate at very high temperature, 500°F not being uncommon. These extremely high-temperature applications require high pressure (and occasionally superheated) steam.

Trap Selection and Safety Factor

Determine the condensate load for process air heaters with the following formula:

$$Q = \frac{F \times C_p \times d \times 60 \text{ min/hr} \times \Delta T}{H}$$

Where:

- Q = Condensate load in lbs/hr
- F = Cubic feet of air per minute
- C_p = Specific heat of air in Btu/lb—°F (from Table CG-34, page CG-57)
- d = Density of air—.075 lbs/cu ft
- ΔT = Temperature rise in °F
- H = Latent heat of steam in Btu/lb (Steam Table, page CG-5)

EXAMPLE: What would be the condensate load on a tunnel dryer coil handling 2,000 CFM of air and requiring a 100°F temperature rise? The steam pressure is 45 psig. Using the formula:

$$Q = \frac{2000 \times .24 \times .075 \times 60 \times 100}{915}$$

$$Q = 236 \text{ lbs/hr}$$

Multiplying by a safety factor of 2—which is recommended for all constant pressure process air heaters—indicates that a trap with a capacity of 472 lbs/hr will be required. This is based on one coil. For higher air temperature rises, additional coils in series may be required.

Safety Factors

For constant steam pressure, use a safety factor of 2:1 at operating pressure differential. For modulating steam pressure, use a safety factor of 3:1 at 1/2 of maximum pressure differential across the trap.

Installation

Give piping for an entire piece of process air heating equipment—including all steam trap connections—adequate allowance for expansion due to the wide temperature variations. Mount traps 10"-12" below the coils with a dirt pocket of at least 6". On both constant and modulated pressure heaters, install a vacuum breaker between the coil and the steam trap. Install an air vent on each coil to remove air and other non-condensables that can cause rapid corrosion.

See Fig. CG-44.

Consider a safety drain if condensate is elevated after the trap or if back pressure is present. See page CG-49 for piping diagram and explanation.

Figure CG-44. Process Air Heater

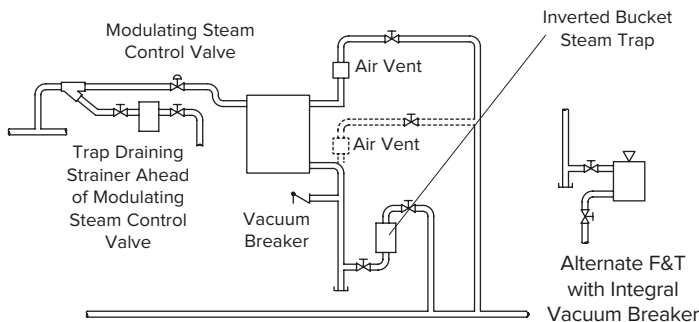

Chart CG-13. Recommendation Chart

(See Page CG-4 for "Feature Code" References.)

Equipment Being Trapped	1st Choice and Feature Code	Constant Pressure		1st Choice and Feature Code	Variable Pressure	
		0-30 psig	Above 30 psig		0-30 psig	Above 30 psig
Process Air Heaters	A, B, F, I, K, M	IB	IB	B, C, G, H, L	F&T	*F&T
	Alternate Choice	F&T	IBLV	Alternate Choice	IBLV	IBLV

*Use IBLV above F&T pressure temperature limitations.

PLEASE NOTE:

1. Provide vacuum breaker wherever subatmospheric pressures occur.
2. Do not use F&T traps on superheated steam.

Designs, materials, weights and performance ratings are approximate and subject to change without notice. Visit armstronginternational.com for up-to-date information.

How To Trap – Shell & Tube Heat Exchangers & Submerged Coils

Submerged coils are heat transfer elements that are immersed in the liquid to be heated, evaporated or concentrated. This type of coil is found in virtually every plant or institution that uses steam. Common examples are water heaters, reboilers, suction heaters, evaporators and vaporizers. These are used in heating water for process or domestic use, vaporizing industrial gases such as propane and oxygen, concentrating in-process fluids such as sugar, black liquor and petroleum, and heating fuel oil for easy transfer and atomization.

Different application requirements involving constant or variable steam pressure determine which type of trap should be used. Trap selection factors include the ability to handle air at low differential pressures, energy conservation and the removal of dirt and slugs of condensate. Three standard methods of sizing help determine the proper type and size traps for coils.

Safety Factor

- 1. Constant Steam Pressure. INVERTED BUCKET TRAPS OR F&T TRAPS**—use a 2:1 safety factor at operating pressure differentials.
- 2. Modulating Steam Pressure. F&T TRAPS OR INVERTED BUCKET TRAPS.**
 - 0-15 psig steam—2:1 at 1/2 psi pressure differential.
 - 16-30 psig steam—2:1 at 2 psi pressure differential.
 - Above 30 psig steam—3:1 at 1/2 of maximum pressure differential across the trap.
- 3. Constant or Modulating Steam Pressure with Syphon Drainage.** An automatic differential condensate controller with a safety factor of 3:1 should be used. An alternate is an IBLV with a 5:1 safety factor.

Apply the safety factor at full differential on constant steam pressure. Apply the safety factor at 1/2 maximum differential for modulating steam pressure.

Figure CG-45. Shell And Tube Heat Exchangers
(Typical Piping Diagram)

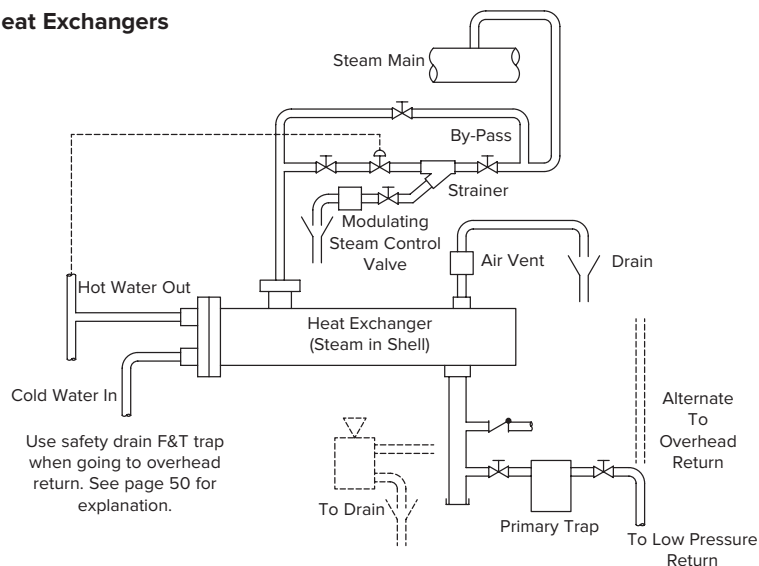

Shell and Tube Heat Exchangers

One type of submerged coil is the shell and tube heat exchanger (Fig. CG-45). In these exchangers, numerous tubes are installed in a housing or shell with confined free area. This ensures positive contact with the tubes by any fluid flowing in the shell. Although the term submerged coil implies that steam is in the tubes and the tubes are submerged in the liquid being heated, the reverse can also be true, where steam is in the shell and a liquid is in the tubes.

Trap Selection for Shell and Tube Heat Exchangers

To determine the condensate load on shell and tube heaters, use the following formula when actual rating is known.* (If heating coil dimensions alone are known, use formula shown for embossed coils. Be sure to select applicable "U" factor):

$$Q = \frac{L \times \Delta T \times C \times 500 \times sg}{H}$$

Where:

- Q = Condensate load in lbs/hr
- L = Liquid flow in GPM
- ΔT = Temperature rise in °F
- C = Specific heat of liquid in Btu/lb-°F (Table CG-33, page 57)
- 500 = 60 min/hr x 8.33 lbs/gal
- sg = Specific gravity of liquid (Table CG-33)
- H = Latent heat of steam in Btu/lb (Steam Table, page 5)

EXAMPLE: Assume a water flow rate of 50 GPM with an entering temperature of 40°F and a leaving temperature of 140°F. Steam pressure is 15 psig. Determine the condensate load.

Using the formula:

$$Q = \frac{50 \text{ GPM} \times 100^\circ\text{F} \times 1 \text{ Btu/lb-}^\circ\text{F} \times 500 \times 1.0 \text{ sg}}{945 \text{ Btu/lb}} =$$

*** Size steam traps for reboilers, vaporizers and evaporators (processes that create vapor) using the formula for EMBOSSED COILS on page 32.**

Rule of Thumb for Computing Condensing Rate for Water Heaters: Raising the temperature of 100 gallons of water 1°F will condense one pound of steam.

Embossed Coils

Very often open tanks of water or chemicals are heated by means of embossed coils (Fig. CG-46). Upsetting grooves in the sheet metal of the two halves produce the spaces for the steam. When welded together, the halves form the passages for steam entry, heat transfer and condensate evacuation.

Trap Selection for Embossed Coils

Calculate the condensate load on embossed coils with the following formula:

$$Q = A \times U \times Dm$$

Where:

Q = Total heat transferred in Btu per hour

A = Area of outside surface of coil in sq ft

U = Overall rate of heat transfer in Btu per hr-sq ft-°F. See Tables CG-20 and CG-21.

Dm = Logarithmic mean temperature difference between steam and liquid (as between inlet and outlet of a heat exchanger) in °F

$$Dm = \frac{D1-D2}{\text{Log}_e \left(\frac{D1}{D2} \right)}$$

D1 = Greatest temperature difference

D2 = Least temperature difference

Logarithmic mean temperature difference can be determined with slightly less accuracy using the nomograph, Chart CG-16 (page 36).

U values are determined by tests under controlled conditions. Tables CG-20 and CG-21 show the commonly accepted range

Type of Service	Circulation	
	Natural	Forced
Steam to Water	50-200	150-1200
1-1/2" Tube Heaters	180	450
3/4" Tube Heaters	200	500
Steam to Oil	10-30	50-150
Steam to Boiling Liquid	300-800	-
Steam to Boiling Oil	50-150	-

Figure CG-46. Thermostatic Controlled Embossed Coil, Syphon Drained

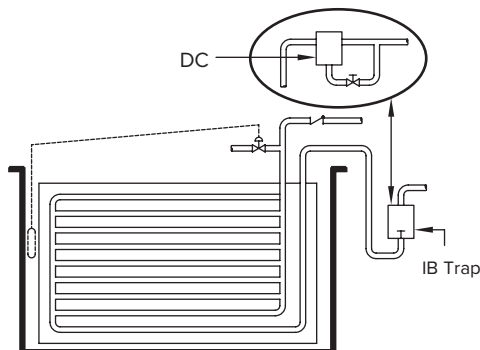

for submerged embossed coils. For trap selection purposes, use a U value that is slightly greater than the conservative U value selected for estimating actual heat transfer.

EXAMPLE:

A = 20 sq ft of coil surface

U = 175 Btu/sq ft-hr-°F

Conditions:

Water in: 40°F

Water out: 150°F

Steam pressure: 125 psig or 353°F

D1 = 353 - 40, or 313

D2 = 353 - 150, or 203

Dividing by 4 to get within range of Chart CG-16 (page 36), we have:

D1 = 78.25

D2 = 50.75

Mean difference from chart is 63°F.

Multiplying by 4, the mean temperature difference for the original values is 252°F. Substituting in the equation:

$$Q = 20 \times 175 \times 252 = 882,000 \text{ Btu/hr}$$

Btu transferred per hour.

Latent heat of steam at 125 psig = 867.6

$$\frac{882,000}{867.6} = 1,016 \text{ lbs condensate per hr}$$

To determine trap capacity required, multiply condensing rate by the recommended safety factor.

Table CG-21. Embossed Coil U Values in Btu/hr-sq ft-°F

Type of Service	Circulation	
	Natural	Forced
Steam to Watery Solutions	100-200	150-275
Steam to Light Oil	40-45	60-110
Steam to Medium Oil	20-40	50-100
Steam to Bunker C	15-30	40-80
Steam to Tar Asphalt	15-25	18-60
Steam to Molten Sulphur	25-35	35-45
Steam to Molten Paraffin	25-35	40-50
Steam to Molasses or Corn Syrup	20-40	70-90
Downtherm to Tar Asphalt	15-30	50-60

Figure CG-47. Continuous Coil, Syphon Drained

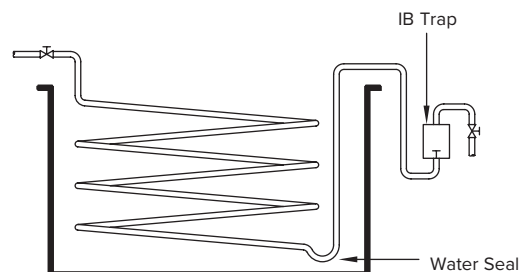

How To Trap – Shell & Tube Heat Exchangers & Submerged Coils

Pipe Coils

Pipe coils are heat transfer tubes immersed in vessels that are large in volume compared to the coils themselves (Fig. CG-47, page 32). This is their primary difference when compared to shell and tube heat exchangers. Like embossed coils, they may be drained by gravity or syphon drained, depending on the conditions prevailing at the installation site. Unlike embossed coils, most pipe coils are installed in closed vessels.

Trap Selection for Pipe Coils

Determine the condensate load for pipe coils by applying one of the formulas, depending on known data. If capacity is known, use the formula under shell and tube heat exchangers. When physical dimensions of coil are known, use the formula under embossed coils.

Installation

When gravity drainage is utilized on shell and tube heat exchangers, embossed coils and pipe coils, locate the steam trap below the heating coil. Under modulating pressure, use a vacuum breaker. This can be integral in F&T traps or mounted off the inlet piping on an inverted bucket trap. Place an ample drip leg ahead of the trap to act as a reservoir. This ensures coil drainage when there is a maximum condensate load and a minimum steam pressure differential.

Avoid lifting condensate from a shell and tube heat exchanger, embossed coil or pipe coil under modulated control.

However, if it must be done, the following is suggested:

1. Do not attempt to elevate condensate more than 1' for every pound of normal pressure differential, either before or after the trap.
2. If condensate lift takes place after the steam trap, install a low-pressure safety drain. (See page 49).
3. If condensate lift takes place ahead of the steam trap (syphon lift), install an automatic differential condensate controller to efficiently vent all flash steam.

For Pounds of Steam Condensed Per sq ft Per Hour of Submerged Coil Surface, see Chart CG-17 (page 36).

Chart CG-14. Recommendation Chart
(See Page 4 for "Feature Code" References.)

Equipment Being Trapped	1st Choice and Feature Code	Constant Pressure		1st Choice and Feature Code	Variable Pressure	
		0-30 psig	Above 30 psig		0-30 psig	Above 30 psig
Shell and Tube Heat Exchangers	B, C, E, F, G, I, K, N, Q	IBLV	IBLV	B, C, G, H, I, L	F&T ¹	F&T ¹
	Alternate Choice	DC F&T	DC *F&T	Alternate Choice	DC IBT	DC IBLV
Embossed Coils and Pipe Coils Syphon Drain	B, C, E, F, G, H, I, K, N, Q	DC	DC	B, C, G, H, I, L	DC	DC
	Alternate Choice	IBLV	IBLV	Alternate Choice	F&T ¹	*F&T ¹
Embossed Coil and Pipe Coils Gravity Drain	B, C, E, F, G, I, K, N, Q	IBLV	IBLV	B, C, G, H, I, L	F&T ¹	*F&T ¹
	Alternate Choice	DC F&T	DC F&T	Alternate Choice	DC IBT	DC IBLV

¹Use IBLV above pressure/temperature limitations.

If dirt and large volumes of air must be handled, an inverted bucket trap with an external thermostatic air vent can be used effectively.

Please Note:

1. Provide vacuum breaker wherever subatmospheric pressures occur.
2. Provide a safety drain when elevating condensate on modulating service.

Evaporators reduce the water content from a product through the use of heat. They are very common to many industries, especially paper, food, textiles, chemical and steel.

An evaporator is a shell and tube heat exchanger where the steam is normally in the shell and the product is in the tubes and in motion. Depending upon the type of product and the desired results, more than one stage or effect of evaporation may be required. The triple effect is the most common, although as many as five or six can be found on some applications.

Single Effect

While the product is being forced through the tubes of the evaporator, heat is added to remove a specific amount of moisture. After this is completed, both the product vapor and the concentrated product are forced into the separating chamber where the vapor is drawn off and may be used elsewhere. The concentrate is then pumped off to another part of the process (Fig. CG-48).

Multiple Effect

In using the multiple effect method, there is a conservation of heat as steam from the boiler is used in the first effect, and then vapor generated from the product is used as the heat source in the second effect. The vapor generated here is then used as the heat source in the third effect and finally heats water for some other process or preheats the incoming feed (Fig. CG-49).

There are many variables in the design of evaporators due to their wide application to many different products. The steam capabilities for evaporators can vary from approximately 1,000 lbs per hour to 100,000 lbs per hour, while steam pressures may vary from a high of 150 psig in the first effect to a low of 24" mercury vacuum in the last effect.

Because evaporators are normally run continuously, there is a uniform load of condensate to be handled. It's important to remember that traps must be selected for the actual pressure differential for each effect.

The three major considerations when trapping evaporators are:

1. Large condensate loads.
2. Low pressure differentials in some effects.
3. The evacuation of air and contaminants.

Safety Factor

- When load is fairly constant and uniform, a 2:1 safety factor should be adequate when applied to an actual condensing load in excess of 50,000 lbs/hr.

- Below 50,000 lbs/hr, use a 3:1 safety factor.

For single and multiple effect evaporators, automatic differential condensate controllers are recommended. In addition to offering continuous operation, DC traps vent air and CO₂ at steam temperature, handle flash steam and respond immediately to slugs of condensate.

Figure CG-48. Single Effect Evaporator System

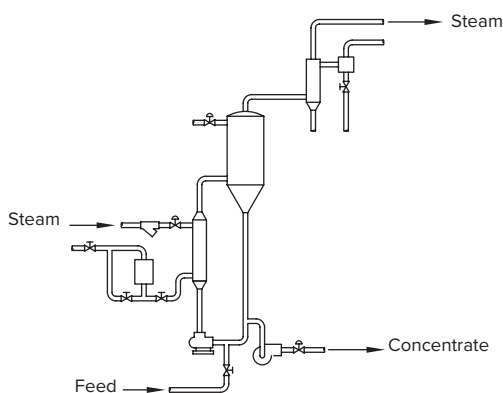

Figure CG-49. Triple Effect Evaporator System

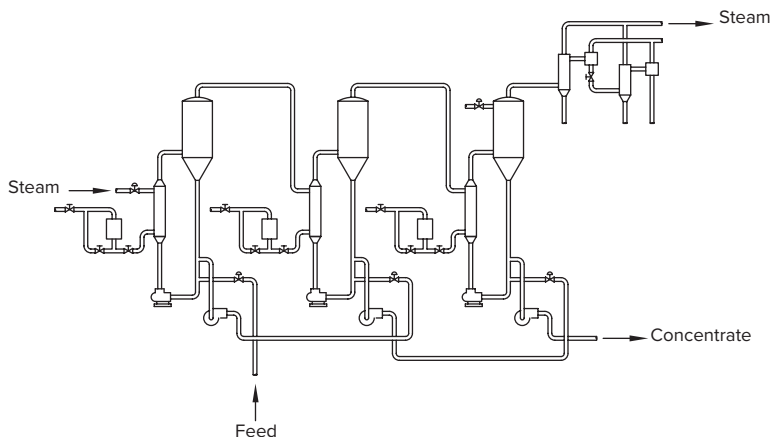

Chart CG-15. Recommendation Chart

(See Page 4 for "Feature Code" References.)

Equipment Being Trapped	1st Choice, Feature Code and Alternate Choice(s)	0-30 psig	Above 30 psig
Evaporator Single Effect	A, F, G, H, K, M, P	DC	DC
	Alternate Choices	IBLV F&T	IBLV F&T
Evaporator Multiple Effect	A, F, G, H, K, M, P	DC	DC
	Alternate Choices	IBLV F&T	IBLV F&T

How to Trap Evaporators

Installation

Because an evaporator is basically a shell and tube heat exchanger with the steam in the shell, there should be separate steam air vents on the heat exchanger. Place these vents at any area where there is a tendency for air to accumulate, such as in the quiet zone of the shell. Install a separate trap on each effect. While the condensate from the first effect may be returned to the boiler, condensate from each successive effect may not be returned to the boiler due to contamination from the product.

Trap Selection for Evaporators

When calculating the condensate load for evaporators, take care in selecting the U value (Btu/hr-sq ft-°F). As a general rule, the following U values can be used:

- 300 for natural circulation evaporators with low pressure steam (up to 25 psig)
- 500 on natural circulation with high pressure (up to 45 psig)
- 750 with forced circulation evaporators

Use the following formula to compute heat transfer for constant steam pressure continuous flow heat exchangers.

$$Q = A \times U \times D_m$$

Where:

Q = Total heat transferred in Btu per hour

A = Area of outside surface of coil in sq ft

U = Overall rate of heat transfer in Btu/hr-sq ft-°F
(See Tables CG-20 and CG-21 on page 32)

D_m = Logarithmic mean temperature difference between steam and liquid (as between inlet and outlet of a heat exchanger) in °F

$$D_m = \frac{D_1 - D_2}{\text{Log}_e \left(\frac{D_1}{D_2} \right)}$$

Where:

D₁ = Greatest temperature difference

D₂ = Least temperature difference

Logarithmic mean temperature difference can be estimated by using the nomograph, Chart CG-16 (page 36).

EXAMPLE:

A = Heat transfer tubes: eight 3/4" OD tubes 12' long

$$\frac{8 \times 12'}{5.09} = 20 \text{ sq ft of coil surface}$$

(from Table CG-24)

U = 500 Btu/hr-sq ft-°F

Conditions:

Water in: 40°F

Water out: 150°F

125 psig or 353°F steam pressure:

D₁ = 353°F - 40°F, or 313°F

D₂ = 353°F - 150°F, or 203°F

Dividing by 4 to get within range of Chart CG-16, we have:

D₁ = 78.25°F

D₂ = 50.75°F

Mean difference from chart is 63°F. Multiplying by 4, the mean temperature difference for the original value is 252°F. Substituting in the equation:

$$Q = 20 \times 500 \times 252 = 2,520,000 \text{ Btu/hr}$$

transferred per hour

Latent heat of steam at 125 psig = 867.6

$$\frac{2,520,000}{867.69} = 2,900 \text{ lbs condensate per hour}$$

To determine trap capacity required, multiply the condensing rate by the recommended safety factor.



How to Trap Evaporators

Table CG-22. Pipe Coil U Values in Btu/hr-sq ft-°F

Type of Service	Circulation	
	Natural	Forced
Steam to Water	50-200	150-200
1-1/2" Tube Heaters	180	450
3/4" Tube Heaters	200	500
Steam to Oil	10-30	50-150
Steam to Boiling Liquid	300-800	-
Steam to Boiling Oil	50-150	-

Table CG-23. Embossed Coil U Values in Btu/hr-sq ft-°F

Type of Service	Circulation	
	Natural	Forced
Steam to Watery Solutions	100-200	150-275
Steam to Light Oil	40-45	60-110
Steam to Medium Oil	20-40	50-100
Steam to Bunker C	15-30	40-80
Steam to Tar Asphalt	15-25	18-60
Steam to Molten Sulphur	25-35	35-45
Steam to Molten Paraffin	25-35	40-50
Steam to Molasses or Corn Syrup	20-40	70-90
Downtherm to Tar Asphalt	15-30	50-60

Chart CG-16. Mean Temperature Difference Chart for Heat Exchange Equipment

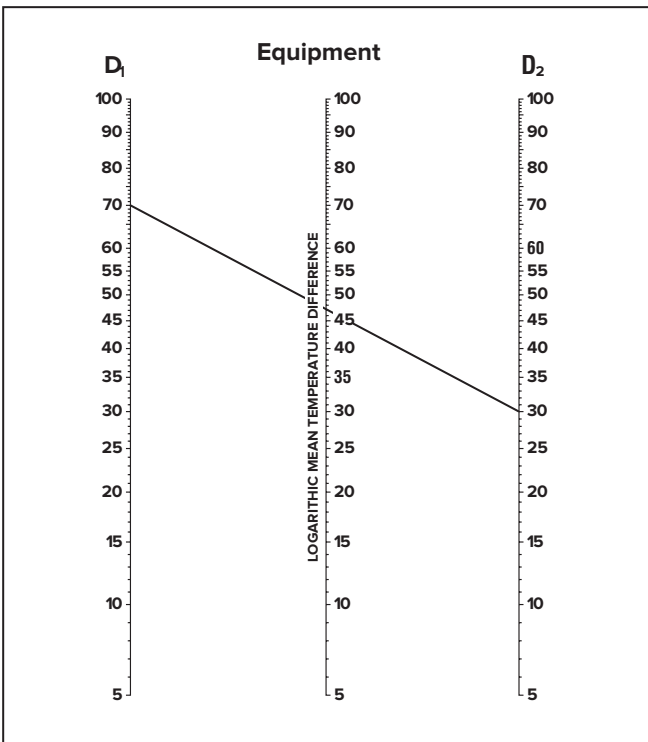

Connect greatest temperature difference on scale **D₁** with least temperature difference on scale **D₂** to read logarithmic mean temperature difference on center scale.

Table CG-24. Pipe Size Conversion Table. (Divide lineal feet of pipe by factor given for size and type of pipe to get square feet of surface)

Pipe Size (in)	Iron Pipe	Copper or Brass Pipe
1/2	4.55	7.63
3/4	3.64	5.09
1	2.90	3.82
1-1/4	2.30	3.05
1-1/2	2.01	2.55
2	1.63	1.91
2-1/2	1.33	1.52
3	1.09	1.27
4	.848	.954

Chart CG-17. Pounds of Steam Condensed Per sq ft Per Hour of Submerged Coil Surface

(See "Conditions" conversion factors below chart)

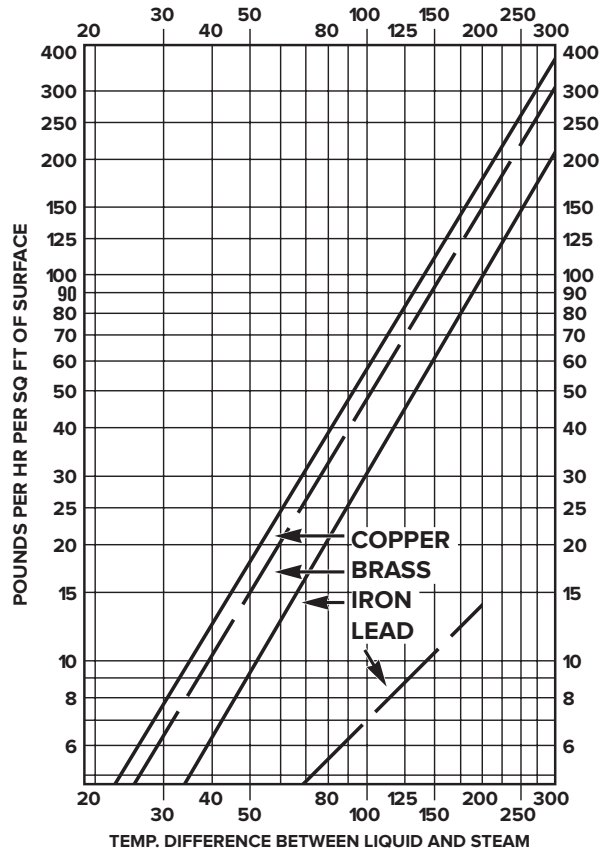

Condition Factors
(Divide chart figures by proper factor)

CONDITIONS	FACTOR
Will remain bright _____	1
Moderate scale _____	2
Liquid contains up to 25% solids _____	3-5
Thick viscous liquids _____	4-8

How to Trap Jacketed Kettles

Steam jacketed kettles are essentially steam jacketed cookers or concentrators. They are found in all parts of the world and in almost every kind of application: meat packing, paper and sugar making, rendering, fruit and vegetable processing and food preparation—to name a few.

There are basically two types of steam jacketed kettles—fixed gravity drain and tilting syphon drain. Each type requires a specialized method for trapping steam, although the major problems involved are common to both.

The most significant problem encountered is air trapped within the steam jacket, which adversely affects the temperature. Jacketed kettles usually perform batch operations, and maintaining a uniform or “cooking” temperature is critical. With an excessive amount of air, wide variations in temperature occur and may result in burnt product and/or slow production. To be more specific, under certain conditions as little as 1/2 of 1% by volume of air in steam can form an insulating film on the heat transfer surface and reduce efficiency as much as 50%. See pages 9 and 10.

A second basic concern in the use of steam jacketed kettles is the need for a steady, thorough removal of condensate. Accumulation of condensate in the jacket leads to unreliable temperature control, reduces the output of the kettle and causes water hammer.

Trap Selection for Jacketed Kettles

Table CG-25 gives the required trap capacities for various size kettles based on the following assumptions:

U = 175 Btu/hr-sq ft-°F

Safety factor of 3 included.

EXAMPLE: What would be the recommended trap capacity for a 34” gravity drained kettle at 40 psig steam? Reading directly from the chart, a trap with a capacity of 1,704 lbs/hr at the operating pressure is required.

For an alternative method of determining condensate, use the following formula:

$$Q = \frac{G \times sg \times Cp \times \Delta T \times 8.3}{H \times t}$$

Where:

- Q = Condensate loads (lbs/hr)
- G = Gallons of liquid to be heated
- sg = Specific gravity of the liquid
- Cp = Specific heat of the liquid
- ΔT = Temperature rise of the liquid °F
- 8.3 = lbs/gal of water
- H = Latent heat of the steam (Btu/lb)
- t = Time in hours for product heating

EXAMPLE: Select a trap for a 250-gallon kettle using 25 psig steam to heat a product with a specific gravity of 0.98 and a specific heat of 0.95 Btu/lb-°F. Starting at room temperature of 70°F, the product will be heated to 180°F in 1/2 hour. (Assume 3:1 safety factor.) Using the formula:

$$\begin{aligned} Q &= \frac{250 \text{ gal} \times 0.98 \times 0.95 \text{ Btu/lb-}^\circ\text{F} \times 110^\circ\text{F} \times 8.3 \text{ lbs/gal}}{933 \text{ Btu/lb} \times 0.5 \text{ hr}} \\ &= \frac{212,500}{466.5} \\ &= 455 \text{ lbs/hr} \end{aligned}$$

Now simply multiply by a safety factor of 3 to get 1,365 lbs/hr of condensate and select the proper type and capacity trap.

Based on the standard requirements and problems involved with fixed gravity drained kettles, the most efficient type trap to use is the inverted bucket.

The inverted bucket trap vents air and CO₂ at steam temperature and provides total efficiency against back pressure. The primary recommendation for tilting syphon drained kettles is the automatic differential condensate controller. In addition to providing the same features as the IB, the DC offers excellent air venting ability at very low pressure and excellent flash steam handling ability. If an IB trap is selected for syphon drained service, use a trap one size larger.

General Recommendations for Maximum Efficiency

Desirable Cooking Speed. Because the product cooked has such an important bearing on trap selection, a plant with many jacketed kettles should conduct experiments using different sizes of traps to determine the size giving best results.

Steam Supply. Use steam lines of ample size to supply steam to the kettles. Locate the inlet nozzle high up on the jacket for best results. It should be slotted so as to give steam flow around the entire jacket area.

Installation

Install traps close to the kettle. You can further increase the dependability and air-handling capability by installing a thermostatic air vent at high points in the jacket. See Figs. CG-50 and CG-51.

Never drain two or more kettles with a single trap. Group drainage will invariably result in short circuiting.

Chart CG-18. Recommendation Chart
(See Page 4 for “Feature Code” References.)

Equipment Being Trapped	1st Choice and Feature Code	Alternate Choices
Jacketed Kettles Gravity Drain	IBLV B, C, E, H, K, N	F&T or Thermostatic
Jacketed Kettles Syphon Drain	DC B, C, E, G, H, K, N, P	IBLV

Figure CG-50. Fixed Gravity Drained Kettle

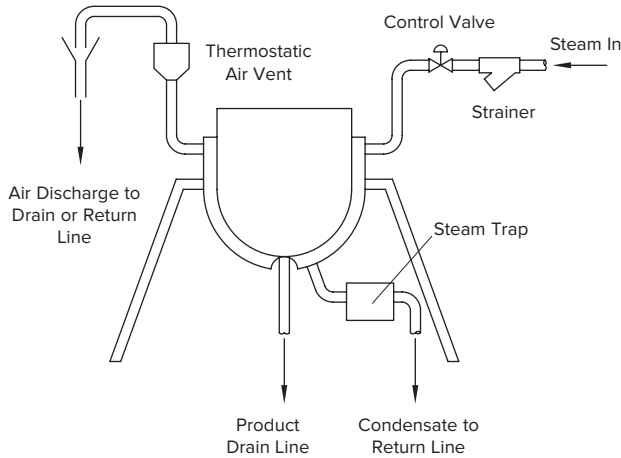

Figure CG-51. Tilting Syphon Drained Kettle

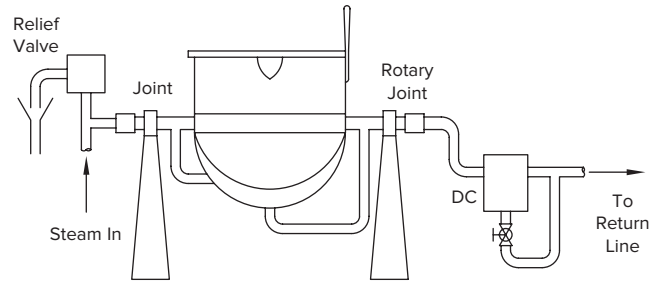

Table CG-25. Condensate Rates in lbs/hr for Jacketed Kettles—Hemispherical Condensing Surface
 Safety factor 3:1 is included. Assume U = 175 Btu/hr-sq ft-°F, 50°F starting temperature.

Kettle Diameter (in)	Heat Transfer Surface (sq ft)	U.S. Gallons of Water in Hemisphere	U.S. Gals. Water per in. of Height Above Hemisphere	Steam Pressure								
				5 psig 227°F	10 psig 240°F	15 psig 250°F	25 psig 267°F	40 psig 287°F	60 psig 307°F	80 psig 324°F	100 psig 338°F	125 psig 353°F
18	3.50	7	1.10	339	366	387	426	474	522	564	603	642
19	3.90	8	1.20	378	408	432	477	528	582	630	669	714
20	4.35	9	1.35	420	456	483	531	588	651	702	747	798
22	5.30	12	1.65	513	555	588	648	717	792	855	912	972
24	6.30	16	1.95	609	660	699	768	852	942	1,017	1,083	1,155
26	7.40	20	2.30	717	774	822	903	1,002	1,107	1,194	1,272	1,356
28	8.50	25	2.65	822	891	942	1,038	1,149	1,269	1,371	1,461	1,557
30	9.80	31	3.05	948	1,026	1,089	1,197	1,326	1,464	1,581	1,686	1,797
32	11.20	37	3.50	1,086	1,173	1,242	1,368	1,515	1,674	1,809	1,926	2,052
34	12.60	45	3.95	1,221	1,320	1,398	1,539	1,704	1,881	1,944	2,166	2,310
36	14.10	53	4.40	1,365	1,476	1,566	1,722	1,908	2,106	2,277	2,424	2,586
38	15.70	62	4.90	1,521	1,644	1,743	1,917	2,124	2,346	2,535	2,700	2,877
40	17.40	73	5.45	1,686	1,821	1,932	2,124	2,355	2,601	2,808	2,991	3,189
42	19.20	84	6.00	1,860	2,010	2,130	2,343	2,598	2,868	3,099	3,300	3,519
44	21.10	97	6.60	2,043	2,208	2,343	2,577	2,856	3,153	3,405	3,627	3,867
46	23.00	110	7.20	2,229	2,409	2,553	2,808	3,111	3,435	3,711	3,954	4,215
48	25.30	123	7.85	2,451	2,649	2,808	3,087	3,423	3,780	4,083	4,350	4,638
54	31.70	178	9.90	3,076	3,324	3,523	3,875	4,296	4,743	5,125	5,458	5,820
60	39.20	245	12.30	3,798	4,104	4,350	4,785	5,304	5,856	6,327	6,738	7,185
72	56.40	423	17.70	5,469	5,910	6,264	6,890	7,638	8,433	9,111	9,703	10,346

How to Trap – Closed, Stationary Steam Chamber Equipment

Closed, stationary steam chamber equipment includes platen presses for the manufacture of plywood and other sheet products, steam jacketed molds for rubber and plastic parts, autoclaves for curing and sterilizing and retorts for cooking.

Product Confined in Steam Jacketed Press

Molded plastic and rubber products such as battery cases, toys, fittings and tires are formed and cured, and plywood is compressed and glue-cured in equipment of this type. Laundry flatwork ironers are a specialized form of press with a steam chamber on one side of the product only.

Trap Selection and Safety Factor

The condensate load for closed, stationary steam chamber equipment is determined by use of the following formula:

$$Q = A \times R \times S$$

Where:

- Q = Condensate load in lbs/hr
- A = Total area of platen in contact with product in sq ft
- R = Condensing rate in lbs/sq ft-hr (For purposes of sizing steam traps, a 3 lbs/sq ft-hr condensing rate may be used)
- S = Safety factor

EXAMPLE: What is the condensate load for a mid platen on a press with 2' x 3' platens, upper and lower? Using the formula:

$$Q = 12 \text{ sq ft} \times 3 \text{ lbs/sq ft-hr} \times 3 = 108 \text{ lbs/hr}$$

End platens would have half this load.

The safety factor recommended for all equipment of this type is 3:1.

The inverted bucket trap is the recommended first choice on steam jacketed chambers, dryers and ironers because it can purge the system, resist hydraulic shock and conserve energy. Disc and thermostatic type traps may be acceptable alternatives.

Figure CG-52. Product Confined In Steam Jacketed Press

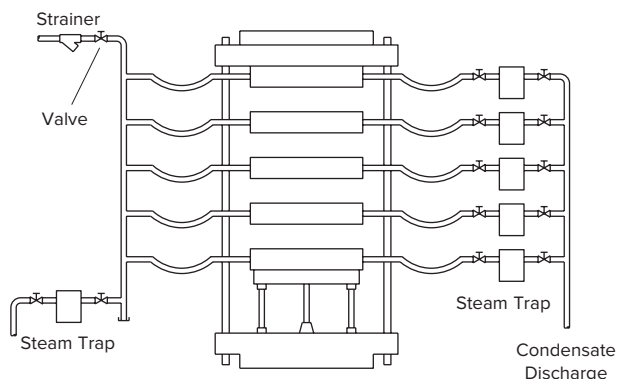

Installation

Although the condensate load on each platen is small, individual trapping is essential to prevent short circuiting, Fig. CG-52. Individual trapping ensures maximum and uniform temperature for a given steam pressure by efficiently draining the condensate and purging the non-condensables.

Direct Steam Injection Into Product Chamber

This type of equipment combines steam with the product in order to cure, sterilize or cook. Common examples are autoclaves used in the production of rubber and plastic products, sterilizers for surgical dressings and gowns, and retorts for cooking food products already sealed in cans.

Trap Selection and Safety Factor

Calculate the condensate load using the following formula:

$$Q = \frac{W \times C \times \Delta T}{H \times t}$$

Where:

- Q = Condensate load in lbs/hr
- W = Weight of the material in lbs
- C = Specific heat of the material in Btu/lb-°F (See page 57)
- ΔT = Material temperature rise in °F
- H = Latent heat of steam in Btu/lb (See Steam Tables on page 5)
- t = Time in hours

EXAMPLE: What will be the condensate load on an autoclave containing 300 lbs of rubber product which must be raised to a temperature of 300°F from a starting temperature of 70°F? The autoclave operates at 60 psig steam pressure and the heat-up process takes 20 minutes. Using the formula:

$$Q = \frac{300 \text{ lbs} \times .42 \text{ Btu/lb-°F} \times 230\text{°F}}{904 \text{ Btu/lb} \times .33 \text{ hr}} = 96 \text{ lbs/hr}$$

Multiply by a recommended safety factor of 3:1 to get the required capacity—288 lbs/hr.

Since steam is in contact with the product, you can anticipate dirty condensate. In addition, the vessel is a large volume chamber that requires special consideration in the purging of condensate and non-condensables. For these reasons, an inverted bucket trap with an auxiliary thermostatic air vent installed at the top of the chamber is recommended.

Where no remote thermostatic air vent can be installed, incorporate the large volume air purging capabilities in the steam trap itself. An automatic differential condensate controller should be considered a possible first choice on large chambers. As an alternative, an F&T or thermostatic trap should be used and be preceded by a strainer, the latter receiving regular checks for free flow.

Installation

Because the steam and condensate is in contact with the product, the trap discharge should almost always be disposed of by some means other than return to the boiler. In virtually all cases this equipment is gravity drained to the trap. However, very often there is a condensate lift after the trap. Because steam pressure is usually constant, this does not present a problem. For thorough air removal and quicker warm-up, install a thermostatic air vent at a high point of the vessel. See Fig. CG-53.

Product in Chamber—Steam in Jacket

Autoclaves, retorts and sterilizers are also common examples of this equipment; however, the condensate is not contaminated from actual contact with the product and can be returned directly to the boiler. Steam traps with purging ability and large volume air venting are still necessary for efficient performance.

Trap Selection and Safety Factor

Size steam traps for “product in chamber—steam in jacket equipment” by using the same formula outlined for direct steam injection. The safety factor is also 3:1.

The inverted bucket trap is recommended because it conserves steam, purges the system and resists hydraulic shock.

Use the IB trap in combination with a thermostatic air vent at the top of the chamber for greater air-handling capability. As an alternative, an F&T or thermostatic trap could be used. On large chambers, where it’s not possible to install the air vent, an automatic differential condensate controller should be considered a possible first choice.

Installation

With “product in chamber—steam in jacket equipment,” the steam and condensate do not come in contact with the product and can be piped to the condensate return system. Where possible, install an auxiliary thermostatic air vent at a remote high point on the steam chamber. See Fig. CG-54.

Chart CG-19. Recommendation Chart (See Page 4 for “Feature Code” References.)		
Equipment Being Trapped	1st Choice and Feature Code	Alternate Choices
Product Confined Steam Jacketed Press	IB A, B, E, K	CD and Thermostatic
Direct Steam Injection into Product Chamber	*IB A, B, E, H, K, N, Q	**DC
Product in Chamber—Steam in Jacket	*IB A, B, E, H, K	Thermostatic and F&T and **DC

*An auxiliary air vent is recommended.

**First choice on large volume vessels.

Figure CG-53. Direct Steam Injection Into Product Chamber

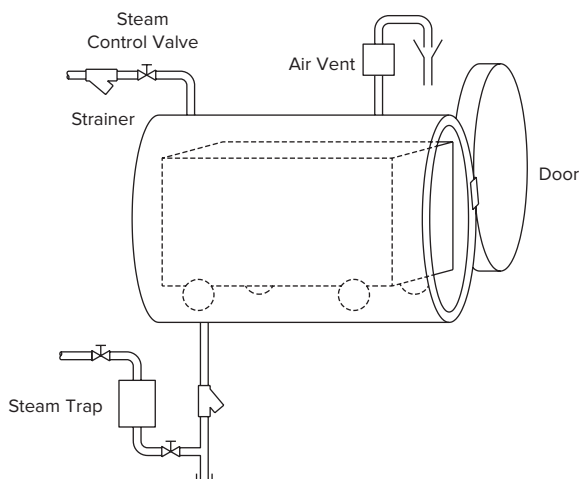
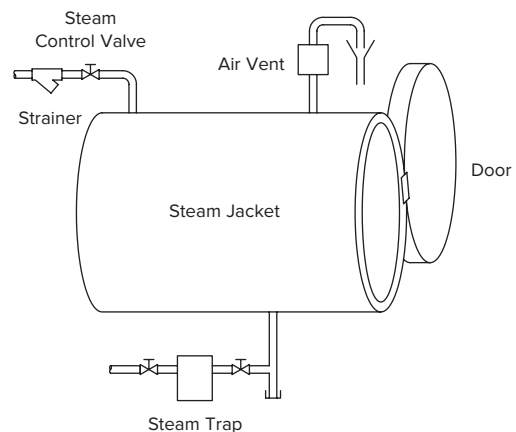

Figure CG-54. Product in Chamber—Steam in Jacket



How to Trap – Rotating Dryers Requiring Syphon Drainage

There are two classifications of rotating dryers which vary significantly in both function and method of operation. The first dries a product by bringing it into contact with the outside of a steam-filled cylinder. The second holds the product inside a rotating cylinder where steam-filled tubes are used to dry it through direct contact. In some applications a steam jacket surrounding the cylinder is also used.

Safety Factor

The safety factor for both kinds of dryers depends on the type of drainage device selected.

- If an automatic differential condensate controller (DC) is installed, use a safety factor of 3:1 based on the maximum load. This will allow sufficient capacity for handling flash steam, large slugs of condensate, pressure variations and the removal of non-condensables. The DC performs these functions on both constant and modulated pressure.
- If an inverted bucket trap with large vent is used, increase the safety factor in order to compensate for the large volume of non-condensable and flash steam that will be present. Under constant-pressure conditions, use a safety factor of 8:1. On modulated pressure increase it to 10:1.

Rotating Steam Filled Cylinder with Product Outside

These dryers are used extensively in the paper, textile, plastic and food industries, where common examples are dry cans, drum dryers, laundry ironers and paper machine dryers. Their speed of operation varies from 1 or 2 rpm to surface velocities as high as 5,000 rpm. Operating steam pressure ranges from subatmospheric to more than 200 psig. Diameters can vary from 6" or 8" to 14' or more. In all cases syphon drainage is required and flash steam will accompany the condensate.

Figure CG-55. Product Outside Dryer

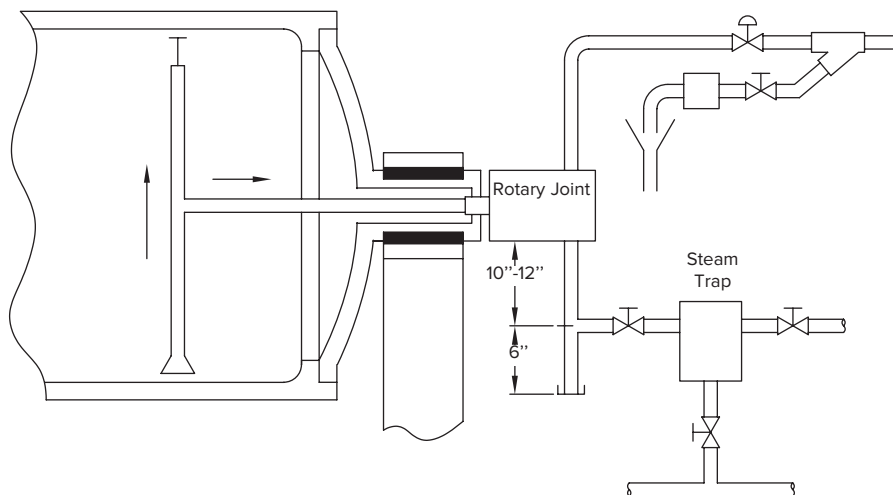

A revolving cylinder drained with a syphon—an internal syphon surrounded by steam. Some condensate flashes back to steam due to the steam jacketed syphon pipe and syphon lifting during evacuation.

Trap Selection

Condensate loads can be determined by use of the following formula:

$$Q = 3.14D \times R \times W$$

Where:

- Q = Condensate load in lbs/hr
- D = Diameter of the dryer in ft
- R = Rate of condensation in lbs/sq ft-hr
- W = Width of dryer in ft

EXAMPLE: Determine the condensate load of a dryer 5 ft in diameter, 10 ft in width and with a condensing rate of 7 lbs/sq ft-hr. Using the formula:

$$\text{Condensate load} = 3.14(5) \times 7 \times 10 = 1,100 \text{ lbs/hr}$$

Based on its ability to handle flash steam, slugs of condensate and purge the system, a DC is the recommended first choice. An IBLV may be adequate if proper sizing procedures are followed.

Chart CG-20. Recommendation Chart (See Page 4 for "Feature Code" References.)		
Equipment Being Trapped	1st Choice and Feature Code	Alternate Choice
Rotating Dryers	DC A, B, K, M, P, N	IBLV*

*On constant pressure use 8:1 safety factor, and on modulated pressure use 10:1.

Product Inside a Rotating Steam Heated Dryer

This type of dryer finds wide application in meat packing as well as food processing industries. Common examples are grain dryers, rotary cookers and bean conditioners.

Their speed of rotation is relatively slow, usually limited to a few rpm, while steam pressure may range from 0-150 psig. These slower rotating speeds permit the condensate to accumulate in the bottom of the collection chamber in practically all cases. Again, syphon drainage is required and flash steam is generated during condensate removal.

Trap Selection

The condensate load generated by these dryers can be determined through use of the following formula:

$$Q = \frac{N \times L \times R}{P}$$

Where:

- Q = Condensate in lbs/hr
- N = Number of tubes
- L = Length of tubes in ft
- R = Condensing rate in lbs/sq ft-hr
(typical 6-9 lbs/sq ft-hr)
- P = Lineal ft of pipe per sq ft of surface
(see Table CG-26)

EXAMPLE: What will be the condensate load on a rotary cooker containing 30 1-1/4" steel pipes 12' in length with a condensing rate of 8 lbs/sq ft-hr?

Using the formula:

$$Q = \frac{30 \times 12 \times 8}{2.30} = 1,252 \text{ lbs/hr}$$

A differential controller is recommended on these dryers for its purging and flash steam handling ability.

The IBLV again requires proper sizing for certain applications.

Installation

In all cases, condensate drainage is accomplished through a rotary joint, Figs. CG-55 and CG-56. The DC should then be located 10"-12" below the rotary joint with an extended 6" dirt pocket. These provide a reservoir for surges of condensate and also a pocket for entrained scale.

Table CG-26. Pipe Size Conversion Table (Divide lineal feet of pipe by factor given for size and type of pipe to get square feet of surface)

Pipe Size (in)	Iron Pipe	Copper or Brass Pipe
1/2	4.55	7.63
3/4	3.64	5.09
1	2.90	3.82
1-1/4	2.30	3.05
1-1/2	2.01	2.55
2	1.61	1.91
2-1/2	1.33	1.52
3	1.09	1.27
4	.848	.954

Figure CG-56. Product Inside Dryer

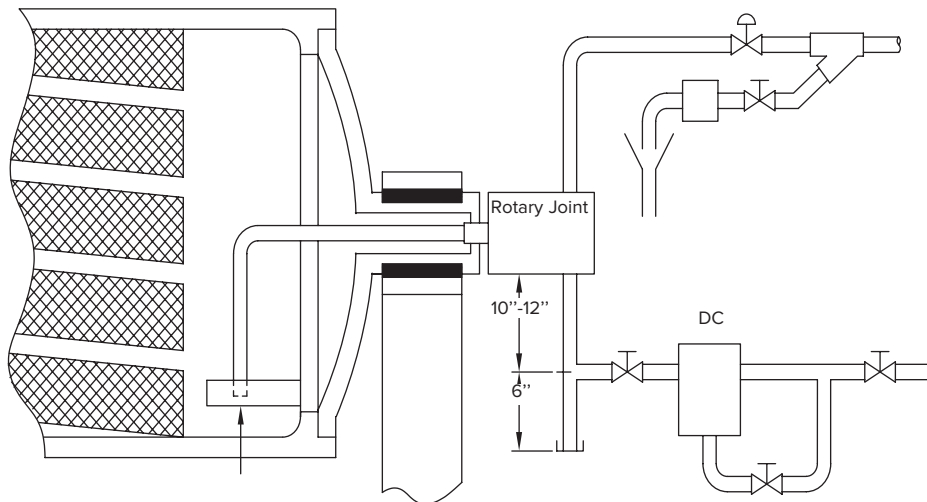

A revolving cylinder drained with a syphon—an internal syphon surrounded by steam. Some condensate flashes back to steam due to the steam jacketed syphon pipe and syphon lifting during evacuation.

How to Trap Flash Tanks

When hot condensate or boiler water, under pressure, is released to a lower pressure, part of it is re-evaporated, becoming what is known as flash steam. The heat content of flash is identical to that of live steam at the same pressure, although this valuable heat is wasted when allowed to escape through the vent in the receiver. With proper sizing and installation of a flash recovery system, the latent heat content of flash steam may be used for space heating; heating or preheating water, oil and other liquids; and low pressure process heating.

If exhaust steam is available it may be combined with the flash. In other cases, the flash will have to be supplemented by live make-up steam at reduced pressure. The actual amount of flash steam formed varies according to pressure conditions. The greater the difference between initial pressure and pressure on the discharge side, the greater the amount of flash that will be generated.

To determine the exact amount, as a percentage, of flash steam formed under certain conditions, refer to page 6 for complete information.

Trap Selection

The condensate load can be calculated using the following formula:

$$Q = L - \frac{L \times P}{100}$$

Where:

- Q = Condensate load in lbs/hr (to be handled by steam trap)
- L = Condensate flow into flash tank in lbs/hr
- P = Percentage of flash

EXAMPLE: Determine the condensate load of a flash tank with 5,000 lbs/hr of 100 psig condensate entering the flash tank held at 10 psig. From page 6, the flash percentage is P = 10.5%. Using the formula:

$$Q = 5,000 - \frac{(5,000 \times 10.5)}{100} = 4,475 \text{ lbs/hr}$$

Due to the importance of energy conservation and operation against back pressure, the trap best suited for flash steam service is the inverted bucket type with large bucket vent. In addition, the IB operates intermittently while venting air and CO₂ at steam temperature.

In some cases, the float and thermostatic type trap is an acceptable alternative. One particular advantage of the F&T is its ability to handle heavy start-up air loads.

Chart CG-21. Recommendation Chart

(See Page 4 for "Feature Code" References.)

Equipment Being Trapped	1st Choice and Feature Code	Alternate Choice
Flash Tanks	IBLV B, E, M, L, I, A, F	F&T or *DC

*Recommended where condensate loads exceed the separating capability of the flash tank.

Refer to Chart CG-3 (page 6) for percentage of flash steam formed when discharging condensate to reduced pressure.

A third type of device that may be the preferred selection in many cases is the automatic differential condensate controller. It combines the best features of both the IB and F&T and is recommended for large condensate loads that exceed the separating capability of the flash tank.

Safety Factor

The increased amount of condensate at start-up and the varying loads during operation accompanied by low pressure differential dictates a safety factor of 3:1 for trapping flash tanks.

Figure CG-57. Typical Flash Tank Piping Sketch

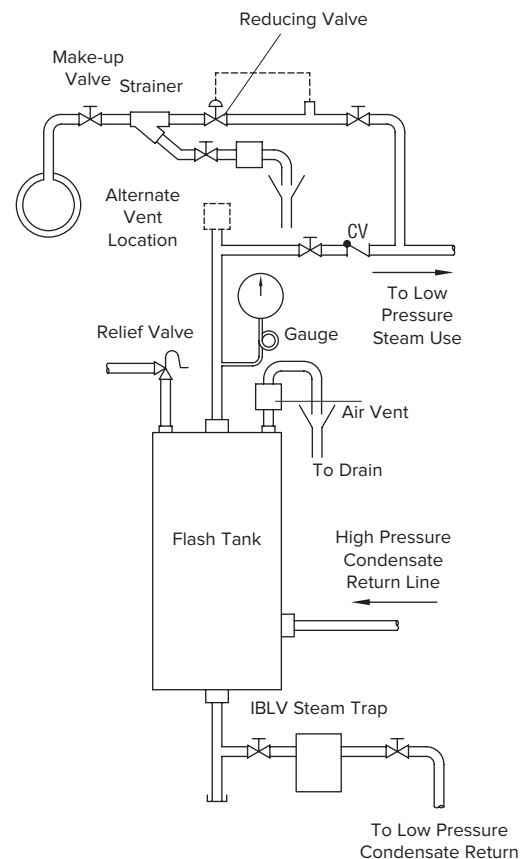

Flash steam tank with live steam make-up, showing recommended fittings and connections. The check valves in the incoming lines prevent waste of flash when a line is not in use. The by-pass is used when flash steam cannot be used. Relief valves prevent pressure from building up and interfering with the operation of the high pressure steam traps. The reducing valve reduces the high pressure steam to the same pressure as the flash, so they can be combined for process work or heating.

Installation

Condensate return lines contain both flash steam and condensate. To recover the flash steam, the return header runs to a flash tank, where the condensate is drained, and steam is then piped from the flash tank to points of use, Fig. CG-57. Since a flash tank causes back pressure on the steam traps discharging into the tank, these traps should be selected to ensure their capability to work against back pressure and have sufficient capacity at the available differential pressures.

Condensate lines should be pitched toward the flash tank, and where more than one line feeds into a flash tank, each line should be fitted with a swing check valve. Then, any line not in use will be isolated from the others and will not be fed in reverse with resultant wasted flash steam. If the trap is operating at low pressure, gravity drainage to the condensate receiver should be provided.

Generally, the location chosen for the flash tank should meet the requirement for maximum quantity of flash steam and minimum length of pipe.

Condensate lines, the flash tank, and the low pressure steam lines should be insulated to prevent waste of flash through radiation. The fitting of a spray nozzle on the inlet pipe inside the tank is not recommended. It may become choked, stop the flow of condensate, and produce a back pressure to the traps.

Low pressure equipment using flash steam should be individually trapped and discharged to a low pressure return. Large volumes of air need to be vented from the flash tank; therefore, a thermostatic air vent should be used to remove the air and keep it from passing through the low pressure system.

Figure CG-58. Flash Steam Recovery from an Air Heater Battery

Flash is taken from the flash tank and combined with live steam, the pressure of which is reduced to that of the flash by a reducing valve.

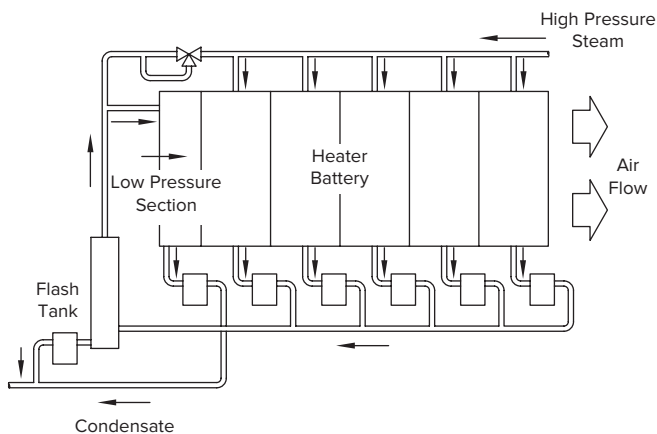

Flash Tank Dimensions

The flash tank can usually be conveniently constructed from a piece of large diameter piping with the bottom ends welded or bolted in position. The tank should be mounted vertically. A steam outlet is required at the top and a condensate outlet at the bottom. The condensate inlet connection should be 6"-8" above the condensate outlet.

The important dimension is the inside diameter. This should be such that the upward velocity of flash to the outlet is low enough to ensure that the amount of water carried over with the flash is small. If the upward velocity is kept low, the height of the tank is not important, but good practice is to use a height of 2'-3'.

It has been found that a steam velocity of about 10' per second inside the flash tank will give good separation of steam and water. On this basis, proper inside diameters for various quantities of flash steam have been calculated; the results are plotted in Chart CG-22. This curve gives the smallest recommended internal diameters. If it is more convenient, a larger tank may be used.

Chart CG-22 does not take into consideration pressure—only weight. Although volume of steam and upward velocity are less at a higher pressure, because steam is denser, there is an increased tendency for priming. Thus it is recommended that, regardless of pressure, Chart CG-22 be used to find the internal diameter.

Chart CG-22. Determination of Internal Diameter of Flash Tank to Handle a Given Quantity of Flash Steam

Find amount of available flash steam (in pounds per hour) on bottom scale, read up to curve and across to vertical scale, to get diameter in inches.

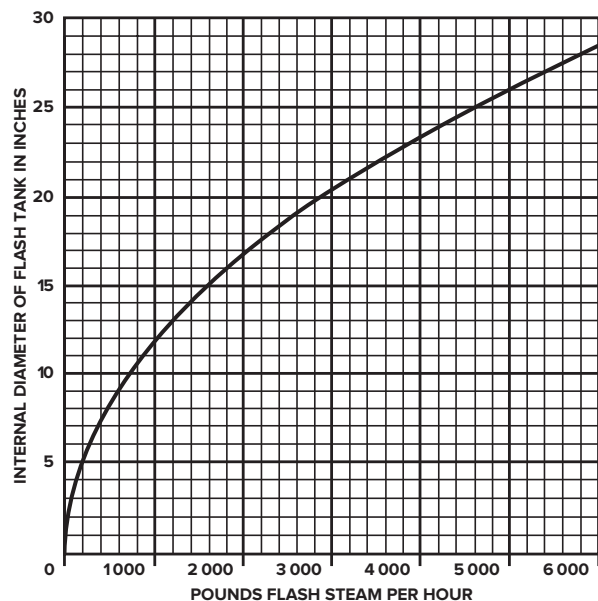

How to Trap Absorption Machines

An absorption refrigeration machine chills water for air conditioning or process use by evaporating a water solution, usually lithium bromide. Steam provides the energy for the concentration part of the cycle and, except for electric pumps, is the only energy input during the entire cycle.

A steam trap installed on a steam absorption machine should handle large condensate loads and purge air at low pressure, modulated conditions.

Trap Selection and Safety Factor

Determine the condensate load produced by a low pressure (normally 15 psig or less) single-stage steam absorption machine by multiplying its rating in tons of refrigeration by 20, the amount of steam in lbs/hr required to produce a ton of refrigeration. This represents consumption at the rated capacity of the machine.

EXAMPLE: How much condensate will a single-stage steam absorption machine with a rated capacity of 500 tons produce?

Multiply the 500-ton machine capacity rating x 20 lbs/hr to get the condensate load—10,000 lbs/hr.

A 2:1 safety factor should be applied to the full capacity condensate load, and the steam trap must be capable of draining this load, at a 1/2 psi differential. In other words, the machine in the example would require a trap capable of handling 20,000 lbs/hr of condensate at 1/2 psi, and the capability of functioning at the maximum pressure differential, usually 15 psi.

In comparison, two-stage absorption machines operate at a higher steam pressure of 150 psig. They have an advantage over single-stage units in that their energy consumption per ton of refrigeration is less (12.2 lbs steam/hr/ton of refrigeration at rated capacity).

EXAMPLE: How much condensate will a two-stage steam absorption machine with a rated capacity of 300 tons produce?

Multiply the 300-ton machine capacity rating x 10 lbs/hr to get the condensate load—3,000 lbs/hr.

On two-stage steam absorption machines, a 3:1 safety factor should be used. Therefore, the example requires a steam trap with a capacity of 9,000 lbs/hr. At pressures above 30 psig, the trap capacity must be achieved at 1/2 maximum pressure differential, which in the example is 75 psi. At pressures below 30 psig, trap capacity must be achieved at 2 psi differential pressure. However, the trap must still be capable of operating at a maximum inlet pressure of 150 psig.

The F&T trap with an integral vacuum breaker is ideally suited for draining both single- and double-stage steam absorption machines. It provides an even, modulated condensate flow and energy-conserving operation. An inverted bucket trap with an external thermostatic air eliminator may also be acceptable.

Installation

Mount the steam trap below the steam coil of the absorption machine with a drip leg height of at least 15" (Fig. CG-59). This ensures a minimum differential pressure across the trap of 1/2 psi. Whichever trap is used, a standby trapping system is recommended for this service. In the event that a component in the drainage system needs maintenance, the absorption machine can operate on the standby system while the repairs are being made. This ensures continuous, uninterrupted service.

In some cases, very heavy condensate loads may require the use of two traps operating in parallel to handle the normal load.

Figure CG-59. Generally approved method of piping steam absorption machine with standby trapping system.

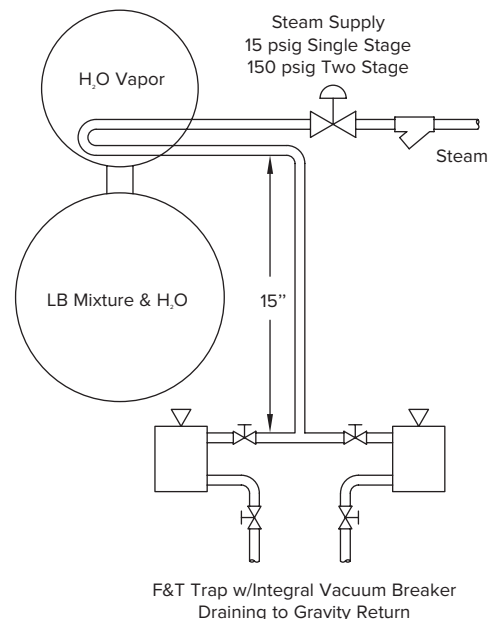

Chart CG-23. Recommendation Chart
(See Page 4 for "Feature Code" References.)

Equipment Being Trapped	1st Choice and Feature Code	Alternate Choice
Steam Absorption Machine	F&T A, B, G	*IB

NOTE: Vacuum breaker and standby system should be provided.

*With external thermostatic air vent.



Trap Selection and Safety Factors

This table provides recommendations for traps likely to be most effective in various applications. The recommended safety factors ensure proper operation under varying

conditions. For more specific information on recommended traps and safety factors, contact your Armstrong Representative.

Table CG-27.			
Application	1st Choice	2nd Choice	Safety Factor
Boiler Header (Superheat)	IBLV	F&T	1.5:1
	IBCV	Wafer	Start-Up Load
	Burnished		
Steam Mains & Branch Lines (Non-Freezing) (Freezing)	IB (CV if pressure varies)	F&T	2:1, 3:1 if @ end of main, ahead of valve, or on branch
	IB	Thermostatic or Disc	Same as above
Steam Separator Steam quality 90% or less	IBLV	DC	3:1
	DC	—	
Tracer Lines	IB	Thermostatic or Disc	2:1
Unit Heaters and Air Handlers (Constant Pressure) (0-15 Variable Pressure) (16-30 Variable Pressure) (>30 Variable Pressure)	IBLV	F&T	3:1
	F&T	IBLV	2:1 @ 1/2 psi Differential
			2:1 @ 2 psi Differential
			3:1 @ 1/2 Max. Pressure Differential
Finned Radiation & Pipe Coils (Constant Pressure) (Variable Pressure)	IB	Thermostatic	3:1 for quick heating 2:1 normally
	F&T	IB	
Process Air Heaters (Constant Pressure) (Variable Pressure)	IB	F&T	2:1
	F&T	IBLV	3:1 @ 1/2 Max. Pressure Differential
Steam Absorption Machine (Chiller)	F&T	IB Ext. Air Vent	2:1 @ 1/2 psi Differential
Shell & Tube Heat Exchangers, Pipe & Embossed Coils (Constant Pressure) (Variable Pressure)	IB	DC or F&T	2:1
	F&T	DC or IBT (If >30 psi IBLV)	<15 psi 2:1 @ 1/2 psi 16-30 psi 2:1 @ 2 psi >30 psi 3:1 @ 1/2 Max. Pressure Differential
Evaporator Single Effect & Multiple Effect	DC	IBLV or F&T	2:1, If load 50,000 lbs/hr use 3:1
Jacketed Kettles (Gravity Drain) (Syphon Drain)	IBLV	F&T or Thermostatic	3:1
	DC	IBLV	
Rotating Dryers	DC	IBLV	3:1 for DC, 8:1 for IB constant pressure, 10:1 for IB variable pressure
Flash Tanks	IBLV	DC or F&T	3:1

- IBLV = Inverted Bucket Large Vent
- IBCV = Inverted Bucket Internal Check Valve
- IBT = Inverted Bucket Thermic Vent
- F&T = Float & Thermostatic
- DC = Differential Condensate Controller

Use an IB with external air vent above the F&T pressure limitations or if the steam is dirty. All safety factors are at the operating pressure differential unless otherwise noted.

Installation and Testing of Armstrong Steam Traps

Before Installing

Run pipe to trap. Before installing the trap, clean the line by blowing down with steam or compressed air. (Clean any strainer screens after this blowdown.)

Trap Location ABCs

Accessible for inspection and repair.

Below drip point whenever possible.

Close to drip point.

Trap Hookups. For typical hookups, see Figs. CG-60 (below) through CG-71, pages 47 through 50.

Shutoff Valves ahead of traps are needed when traps drain steam mains, large water heaters, etc., where system cannot be shut down for trap maintenance. They are not needed for small steam-heated machines—a laundry press, for example. Shutoff valve in steam supply to machine is usually sufficient.

Shutoff Valves in trap discharge line are needed when trap has a by-pass. It is a good idea when there is high pressure in discharge header. See also Check Valves.

Figure CG-60.
Typical IB Hookup

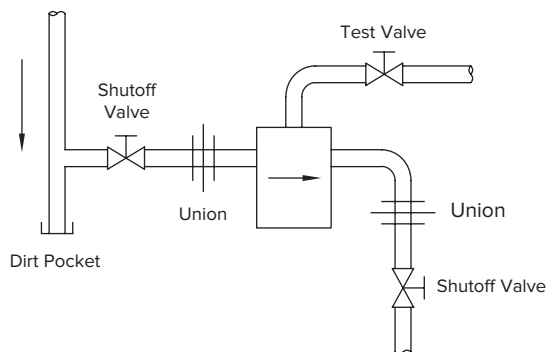
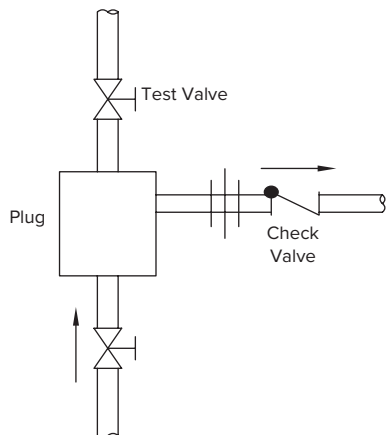

Figure CG-62.
Typical IB Bottom Inlet—Side Outlet Hookup



By-passes (Figs. CG-64 and CG-65) are discouraged, for if left open, they will defeat the function of the trap. If continuous service is absolutely required, use two traps in parallel, one as a primary, one as a standby.

Unions. If only one is used, it should be on discharge side of trap. With two unions, avoid horizontal or vertical in-line installations. The best practice is to install at right angles as in Figs. CG-60 and CG-64, or parallel as in Fig. CG-65.

Standard Connections. Servicing is simplified by keeping lengths of inlet and outlet nipples identical for traps of a given size and type. A spare trap with identical fittings and half unions can be kept in storeroom. In the event a trap needs repair, it is a simple matter to break the two unions, remove the trap, put in the spare and tighten the unions. Repairs can then be made in the shop and the repaired trap, with fittings and half unions, put back in stock.

Test Valves (Fig. CG-60) provide an excellent means of checking trap operation. Use a small plug valve. Provide a check valve or shutoff valve in the discharge line to isolate trap while testing.

Figure CG-61.
Typical IB Bottom Inlet—Top Outlet Hookup

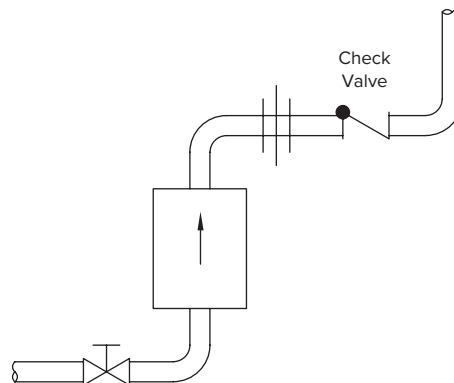
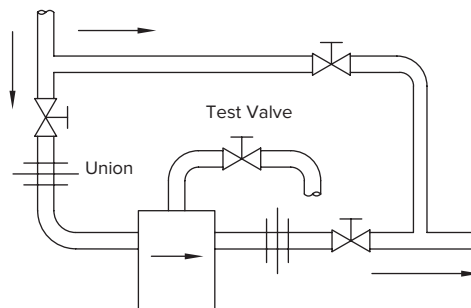

Figure CG-63.
Typical IB By-pass Hookup



Strainers. Install strainers ahead of traps if specified or when dirt conditions warrant their use. Some types of traps are more susceptible to dirt problems than others—see Recommendation Chart on page 4.

Some traps have built-in strainers. When a strainer blowdown valve is used, shut off steam supply valve before opening strainer blowdown valve. Condensate in trap body will flash back through strainer screen for thorough cleaning. Open steam valve slowly.

Dirt Pockets are excellent for stopping scale and core sand, and eliminating erosion that can occur in elbows when dirt pockets are not provided. Clean periodically.

Syphon Installations require a water seal and, with the exception of the DC, a check valve in or before the trap. Syphon pipe should be one size smaller than nominal size of trap used but not less than 1/2" pipe size.

Elevating Condensate. Do not oversize the vertical riser. In fact, one pipe size smaller than normal for the job will give excellent results.

Check Valves are frequently needed. They are a must if no discharge line shutoff valve is used. Fig. CG-63 shows three possible locations for external check valves—Armstrong inverted bucket traps are available with internal check valves, while disc traps act as their own check valve. Recommended locations are given in Fig. CG-63.

Discharge Line Check Valves prevent backflow and isolate trap when test valve is opened. Normally installed at location B, Fig. CG-63. When return line is elevated and trap is exposed to freezing conditions, install check valve at location A.

Inlet Line Check Valves prevent loss of seal if pressure should drop suddenly or if trap is above drip point in IB traps. Armstrong Stainless Steel Check Valve in trap body, location D, Fig. CG-63, is recommended. If swing check is used, install at location C.

Figure CG-64.
Possible Check Valve Locations

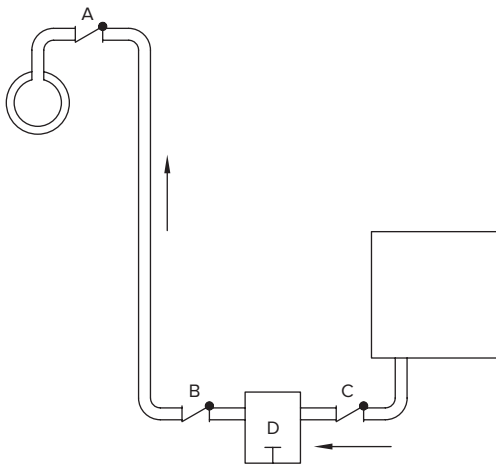

Figure CG-65.
Typical IB By-pass Hookup, Bottom Inlet—Top Outlet

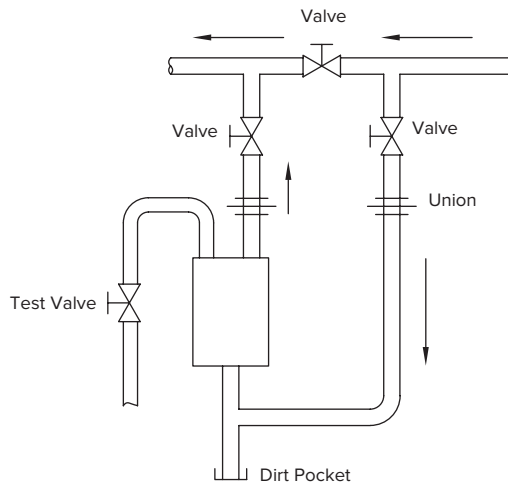
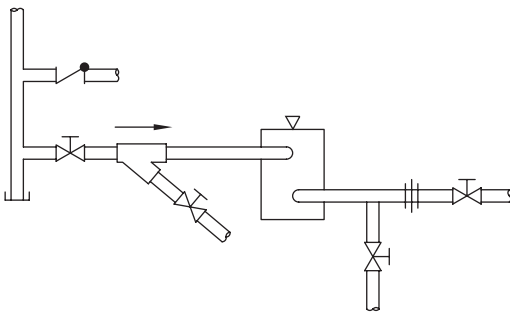

Figure CG-66.
Typical F&T Hookup



Installation and Testing of Armstrong Steam Traps

Protection Against Heat Exchanger Stall

Stall occurs when the inlet pressure will fall below the outlet pressure of a steam trap. In these situations, a condensate pump should be used to overcome the back pressure, return the condensate adequately, and avoid stalling the heat exchanger. When a condensate pump is not practical, a **Safety Drain Trap** should be used whenever there is a likelihood that the inlet pressure will fall below the outlet pressure of a primary steam trap, especially in the presence of freezing air. One such application would be on a modulated pressure heating coil that must be drained with an elevated return line. In the event of insufficient drainage from the primary trap, condensate rises into the safety drain and is discharged before it can enter the heat exchanger. An F&T trap makes a good safety drain because of its ability to handle large amounts of air and its simplicity of operation. Safety drain trap should be same size (capacity) as primary trap.

The proper application of a safety drain is shown in Fig. CG-66. The inlet to the safety drain must be located on the heat exchanger drip leg, above the inlet to the primary trap. It must discharge to an open sewer. The drain plug of the safety drain is piped to the inlet of the primary trap. This prevents the discharge of condensate formed in the safety drain by body radiation when the primary trap is active. The safety drain has an integral vacuum breaker to maintain operation when pressure in the heat exchanger falls below atmospheric. The inlet of the vacuum breaker should be fitted with a gooseneck to prevent dirt from being sucked in when it operates. The vacuum breaker inlet should be provided with a riser equal in elevation to the bottom of the heat exchanger to prevent water leakage when the vacuum breaker is operating, but the drip leg and trap body are flooded.

Protection Against Freezing

A properly selected and installed trap will not freeze as long as steam is coming to the trap. If the steam supply should be shut off, the steam condenses, forming a vacuum in the heat exchanger or tracer line. This prevents free drainage of the condensate from the system before freezing can occur. Therefore, install a vacuum breaker between the equipment being drained and the trap. If there is not gravity drainage through the trap to the return line, the trap and discharge line should be drained manually or automatically by means of a freeze protection drain. Also, when multiple traps are installed in a trap station, insulating the traps can provide freeze protection.

Anti-Freeze Precautions.

1. Do not oversize trap.
2. Keep trap discharge lines very short.
3. Pitch trap discharge lines down for fast gravity discharge.
4. Insulate trap discharge lines and condensate return lines.
5. Where condensate return lines are exposed to ambient weather conditions, tracer lines should be considered.
6. If the return line is overhead, run vertical discharge line adjacent to drain line to top of return header and insulate drain line and trap discharge line together. See Fig. CG-67.

NOTE: A long horizontal discharge line invites trouble. Ice can form at the far end, eventually sealing off the pipe. This prevents the trap from operating. No more steam can enter the trap, and the water in the trap body freezes.

Figure CG-67. Typical Safety Drain Trap Hookup.

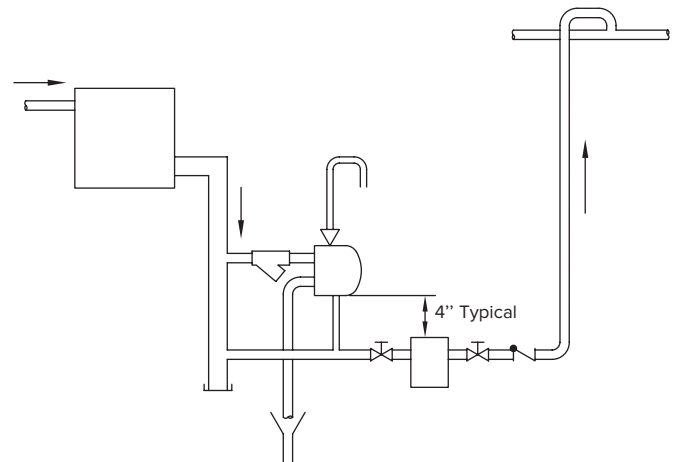

Figure CG-68. Typical Condensate Pump Hookup.

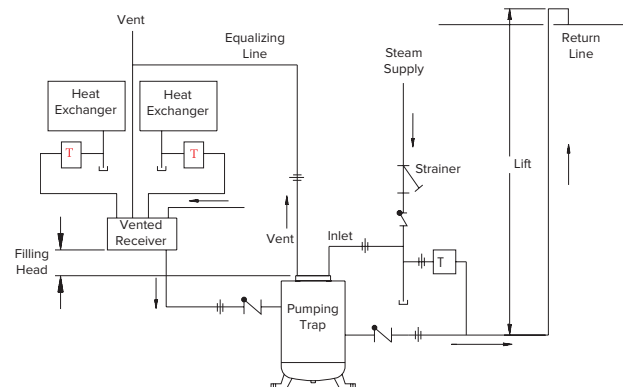
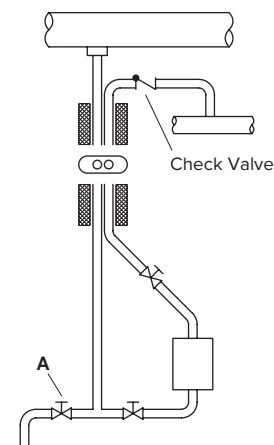

Figure CG-69.



Outdoor installation to permit ground level trap testing and maintenance when steam supply and return lines are high overhead. Drain line and trap discharge line are insulated together to prevent freezing. Note location of check valve in discharge line and blowdown valve **A** that drains the steam main when trap is opened for cleaning or repair.

Testing Armstrong Steam Traps

Testing Schedule.

For maximum trap life and steam economy, a regular schedule should be set up for trap testing and preventive maintenance. Trap size, operating pressure and importance determine how frequently traps should be checked.

Table CG-28. Suggested Yearly Trap Testing Frequency

Operating Pressure (psig)	Application			
	Drip	Tracer	Coil	Process
0-100	1	1	2	3
101-250	2	2	2	3
251-450	2	2	3	4
451 and above	3	3	4	12

How to Test

The **test valve method** is best. Fig. CG-60 (page 47) shows correct hookup, with shutoff valve in return line to isolate trap from return header. Here is what to look for when test valve is opened:

1. **Condensate Discharge**—Inverted bucket and disc traps should have an intermittent condensate discharge. F&T traps should have a continuous condensate discharge, while thermostatic traps can be either continuous or intermittent, depending on the load. When an IB trap has an extremely small load it will have a continuous condensate discharge which causes a dribbling effect. This mode of operation is normal under this condition.
2. **Flash Steam**—Do not mistake this for a steam leak through the trap valve. Condensate under pressure holds more heat units-Btu-per pound than condensate at atmospheric pressure. When condensate is discharged, these extra heat units re-evaporate some of the condensate. See description of flash steam on page 6.

How to Identify Flash: Trap users sometimes confuse flash steam with leaking steam. Here's how to tell the difference: If steam blows out continuously, in a "blue" stream, it's leaking steam. If steam "floats" out intermittently (each time the trap discharges) in a whitish cloud, it's flash steam.

3. **Continuous Steam Blow**—Trouble. Refer to page 51.

4. **No Flow**—Possible trouble. Refer to page 51.

Listening Device Test. Use a listening device or hold one end of a steel rod against the trap cap and the other end against your ear. You should be able to hear the difference between the intermittent discharge of some traps and the continuous discharge of others. This correct operating condition can be distinguished from the higher velocity sound of a trap blowing through. Considerable experience is required for this method of testing, as other noises are telegraphed along the pipe lines.

Pyrometer Method of Testing. This method may not give accurate results, depending on the return line design and the diameter of the trap orifice. Also, when discharging into a common return, another trap may be blowing through, causing a high temperature at the outlet of the trap being tested. Better results can be obtained with a listening device. Request Armstrong Bulletin 310.

Figure CG-70. Typical Disc Trap Hookup

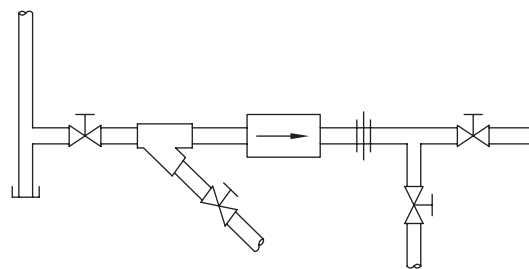

Figure CG-71. Typical Thermostatic Hookup

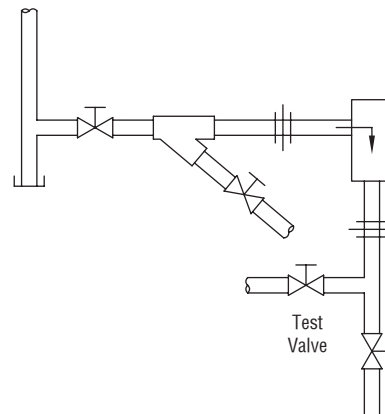
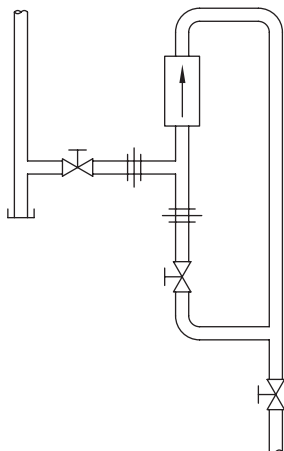

Figure CG-69. Typical DC Hookup



Troubleshooting Armstrong Steam Traps

The following summary will prove helpful in locating and correcting nearly all steam trap troubles. Many of these are actually system problems rather than trap troubles.

More detailed troubleshooting literature is available for specific products and applications—consult factory.

Whenever a trap fails to operate and the reason is not readily apparent, the discharge from the trap should be observed. If the trap is installed with a test outlet, this will be a simple matter—otherwise, it will be necessary to break the discharge connection.

Cold Trap—No Discharge

If the trap fails to discharge condensate, then:

- A.** Pressure may be too high.
 - 1. Wrong pressure originally specified.
 - 2. Pressure raised without installing smaller orifice.
 - 3. PRV out of order.
 - 4. Pressure gauge in boiler reads low.
 - 5. Orifice enlarged by normal wear.
 - 6. High vacuum in return line increases pressure differential beyond which trap may operate.
- B.** No condensate or steam coming to trap.
 - 1. Stopped by plugged strainer ahead of trap.
 - 2. Broken valve in line to trap.
 - 3. Pipe line or elbows plugged.
- C.** Worn or defective mechanism.
Repair or replace as required.
- D.** Trap body filled with dirt.
Install strainer or remove dirt at source.
- E.** For IB, bucket vent filled with dirt. Prevent by:
 - 1. Installing strainer.
 - 2. Enlarging vent slightly.
 - 3. Using bucket vent scrubbing wire.
- F.** For F&T traps, if air vent is not functioning properly, trap will likely air bind.
- G.** For thermostatic traps, the bellows element may rupture from hydraulic shock, causing the trap to fail closed.
- H.** For disc traps, trap may be installed backward.

Hot Trap—No Discharge

- A.** No condensate coming to trap.
 - 1. Trap installed above leaky by-pass valve.
 - 2. Broken or damaged syphon pipe in syphon drained cylinder.
 - 3. Vacuum in water heater coils may prevent drainage.
Install a vacuum breaker between the heat exchanger and the trap.

Steam Loss

If the trap blows live steam, the trouble may be due to any of the following causes:

- A.** Valve may fail to seat.
 - 1. Piece of scale lodged in orifice.
 - 2. Worn parts.

- B.** IB trap may lose its prime.
 - 1. If the trap is blowing live steam, close the inlet valve for a few minutes. Then gradually open. If the trap catches its prime, chances are the trap is all right.
 - 2. Prime loss is usually due to sudden or frequent drops in steam pressure. On such jobs, the installation of a check valve is called for—location D or C in Fig. CG-63 (page 48). If possible, locate trap well below drip point.
- C.** For F&T and thermostatic traps, thermostatic elements may fail to close.

Continuous Flow

If an IB or disc trap discharges continuously, or an F&T or thermostatic trap discharges at full capacity, check the following:

- A.** Trap too small.
 - 1. A larger trap, or additional traps, should be installed in parallel.
 - 2. High pressure traps may have been used for a low pressure job. Install right size of internal mechanism.
- B.** Abnormal water conditions. Boiler may foam or prime, throwing large quantities of water into steam lines. A separator should be installed or else the feed water conditions should be remedied.

Sluggish Heating

When trap operates satisfactorily, but unit fails to heat properly:

- A.** One or more units may be short-circuiting. The remedy is to install a trap on each unit. See page 17.
- B.** Traps may be too small for job even though they may appear to be handling the condensate efficiently. Try next larger size trap.
- C.** Trap may have insufficient air-handling capacity, or the air may not be reaching trap. In either case, use auxiliary air vents.

Mysterious Trouble

If trap operates satisfactorily when discharging to atmosphere, but trouble is encountered when connected with return line, check the following:

- A.** Back pressure may reduce capacity of trap.
 - 1. Return line too small—trap hot.
 - 2. Other traps may be blowing steam—trap hot.
 - 3. Atmospheric vent in condensate receiver may be plugged—trap hot or cold.
 - 4. Obstruction in return line—trap hot.
 - 5. Excess vacuum in return line—trap cold.

Imaginary Troubles

If it appears that steam escapes every time trap discharges, remember: Hot condensate forms flash steam when released to lower pressure, but it usually condenses quickly in the return line. See Chart CG-4 on page 6.

Sizing Charts

Chart CG-25, page 53, is the basic chart for determining the flow rate and velocity of steam in Schedule 40 pipe for various values of pressure drop per 100 ft, based on 0 psig saturated steam. Using the multiplier chart (Chart CG-24), Chart CG-25 can be used at all saturation pressures between 0 and 200 psig (see Example).

These Charts are based on the Moody Friction Factor, which considers the Reynolds number and the roughness of the internal pipe surfaces.

Notes: Based on Moody Friction Factor where flow of condensate does not inhibit the flow of steam. See Chart CG-24 for obtaining flow rates and velocities of all saturation pressures between 0 to 200 psig: see Example.

Pipe Sizing

Two principal factors determine pipe sizing in a steam system:

1. The initial pressure at the boiler and the allowable pressure drop of the total system. The total pressure drop in the system should not exceed 20% of the total maximum pressure at the boiler. This includes all drops—line loss, elbows, valves, etc. Remember, pressure drops are a loss of energy.

Chart CG-24. Velocity Multiplier Chart for CG-25.

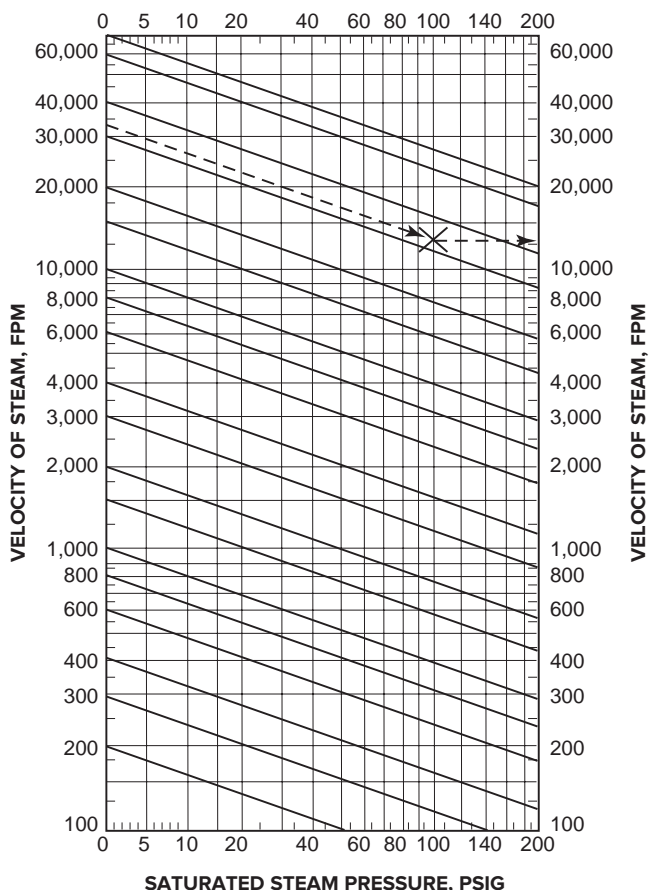

2. Steam velocity. Erosion and noise increase with velocity. Reasonable velocities for process steam are 6,000 to 12,000 fpm, but lower pressure heating systems normally have lower velocities. Another consideration is future expansion. Size your lines for the foreseeable future. If ever in doubt, you will have less trouble with oversized lines than with ones that are marginal.

Use of Basic and Velocity Multiplier Charts

Example.

Given a flow rate of 6,700 lb/hr, an initial steam pressure of 100 psig, and a pressure drop of 11 psi/100 ft, find the size of Schedule 40 pipe required and the velocity of steam in the pipe.

Solution: The following steps are illustrated by the broken line on Chart CG-25 and Chart CG-24.

1. Enter Chart CG-25 at a flow rate of 6,700 lb/hr, and move vertically to the horizontal line at 100 psig.
2. Follow inclined multiplier line (upward and to the left) to horizontal 0 psig line. The equivalent mass flow at 0 psig is about 2,500 lb/hr.
3. Follow the 2,500 lb/hr line vertically until it intersects the horizontal line at 11 psi per 100 ft pressure drop. Nominal pipe size is 2-1/2 in. The equivalent steam velocity at 0 psig is about 32,700 fpm.
4. To find the steam velocity at 100 psig, locate the value of 32,700 fpm on the ordinate of the velocity multiplier chart (Chart CG-24) at 0 psig.
5. Move along the inclined multiplier line (downward and to the right) until it intersects the vertical 100 psig pressure line. The velocity as read from the right (or left) scale is about 13,000 fpm.

NOTE: Steps 1 through 5 would be rearranged or reversed if different data were given.

Reproduced with permission of the American Society of Heating, Refrigerating and Air-Conditioning Engineers from the 1997 ASHRAE Handbook.

Chart CG-25. Flow Rate and Velocity of Steam in Schedule 40 Pipe at Saturation Pressure of 0 psig

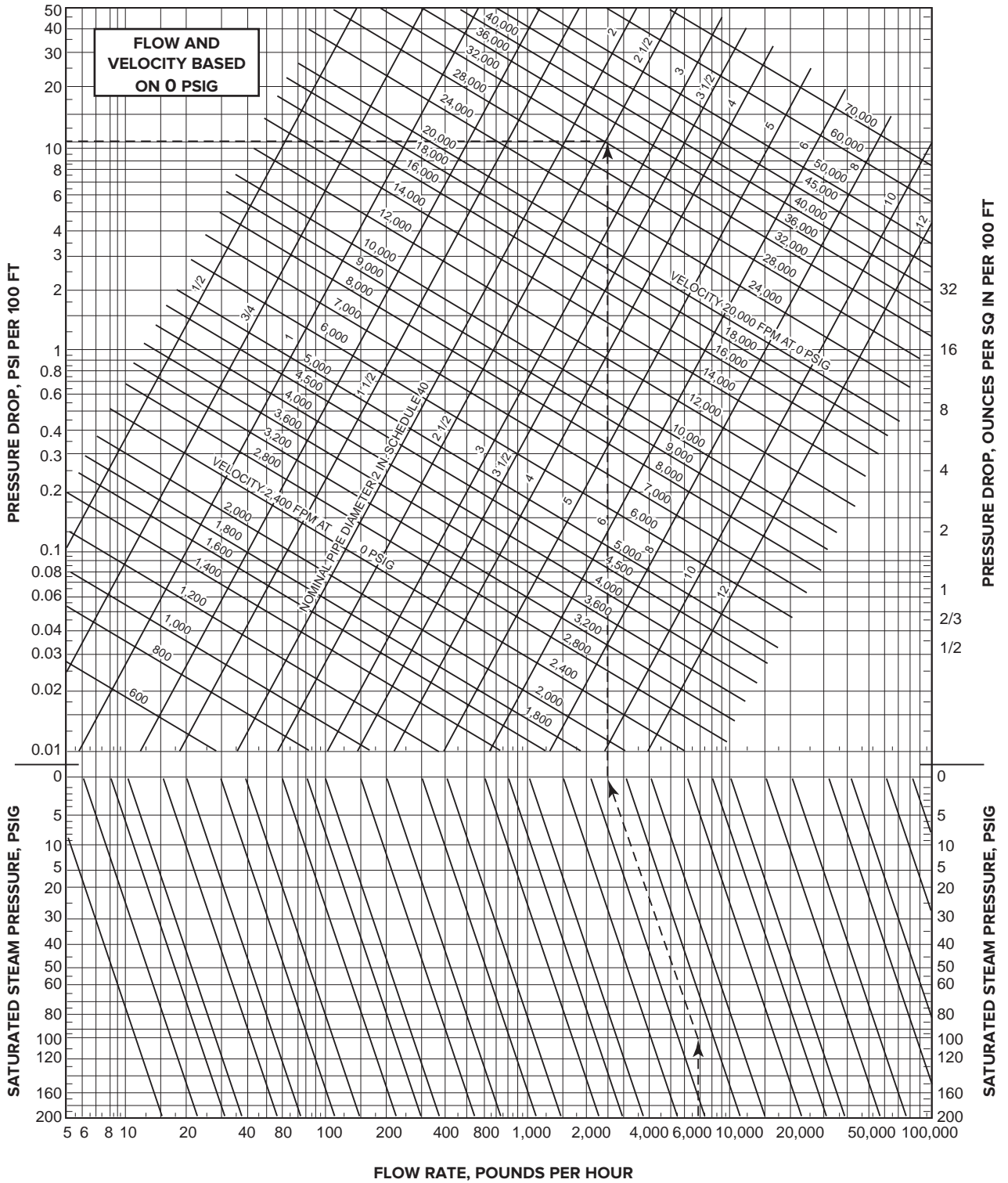

Designs, materials, weights and performance ratings are approximate and subject to change without notice. Visit armstronginternational.com for up-to-date information.



How to Size Condensate Return Lines

The sizing of condensate return lines presents several problems that differ from those of sizing steam or water lines. The most significant of these is the handling of flash steam. Although a return line must handle both water and flash steam, the volume of flash steam is many times greater than the volume of condensate. For the values in Chart CG-26 the volume of flash steam is 96% to 99% of the total volume. Consequently, only flash steam is considered in Chart CG-26.

Condensate return lines should be sized to have a reasonable velocity at an acceptable pressure drop. Chart CG-26 is based on having a constant velocity of 7,000 feet per minute or below, using Schedule 40 pipe. Additional factors that should also be considered—depending on water conditions—are dirt, fouling, corrosion and erosion.

For a given supply pressure to the trap and a return line pressure, along with an assumed pressure drop per 100 feet of pipe ($\Delta P/L$) and knowing the condensate flow rate, the proper pipe diameter can be selected from Chart CG-26.

How to Use Chart CG-26

Example 1: A condensate system has the steam supply at 30 psig. The return line is non-vented and at 0 psig. The return line is to have the capacity for returning 2,000 lbs/hr of condensate. What must be the size of the return line?

Solution: Since the system will be throttling the condensate from 30 psig to 0 psig, there will be flash steam (assuming no subcooling), and the system will be a dry-closed (not completely full of liquid and not vented to atmosphere) return. The data in Chart CG-26 can be used. A pressure of 1/4 psig per 100 feet is selected. In Chart CG-26 for a 30 psig supply and a 0 psig return for $\Delta P/L = 1/4$, a pipe size for the return line of 2" is selected.

Example 2: A condensate return system has the steam supply at 100 psig and the return line is non-vented and at 0 psig. The return line is horizontal and must have a capacity of 2,500 lbs/hr. What size pipe is required?

Solution: Since the system will be throttling non-subcooled condensate from 100 psig to 0 psig, there will be flash steam, and the system will be a dry-closed return. Selecting a pressure drop of 1 psi per 100 feet yields from Chart CG-26 a non-recommended situation (a). Select a pressure drop of 1/4 psi per 100 feet and then a 2-1/2" pipe can be used for this system.

$\Delta P/L$ psi/100'	Supply Pressure = 5 psig			Supply Pressure = 15 psig			Supply Pressure = 30 psig			Supply Pressure = 50 psig		
	Return Pressure = 0 psig			Return Pressure = 0 psig			Return Pressure = 0 psig			Return Pressure = 0 psig		
D, in	1/16	1/4	1	1/16	1/4	1	1/16	1/4	1	1/16	1/4	1
1/2	240	520	1,100	95	210	450	60	130	274	42	92	200
3/4	510	1,120	2,400	210	450	950	130	280	590	91	200	420
1	1,000	2,150	a	400	860	a	250	530	1,120	180	380	a
1-1/4	2,100	4,500	a	840	1,800	a	520	1,110	a	370	800	a
1-1/2	3,170	6,780	a	1,270	2,720	a	780	1,670	a	560	1,200	a
2	6,240	13,300	a	2,500	5,320	a	1,540	3,270	a	1,110	2,350	a
2-1/2	10,000	21,300	a	4,030	8,520	a	2,480	5,250	a	1,780	3,780	a
3	18,000	a	a	7,200	a	a	4,440	9,360	a	3,190	a	a
4	37,200	a	a	14,900	a	a	9,180	a	a	6,660	a	a
6	110,500	a	a	44,300	a	a	27,300	a	a	19,600	a	a
8	228,600	a	a	91,700	a	a	56,400	a	a	40,500	a	a

$\Delta P/L$ psi/100'	Supply Pressure = 100 psig			Supply Pressure = 150 psig			Supply Pressure = 100 psig			Supply Pressure = 150 psig		
	Return Pressure = 0 psig			Return Pressure = 0 psig			Return Pressure = 15 psig			Return Pressure = 15 psig		
D, in	1/16	1/4	1	1/16	1/4	1	1/16	1/4	1	1/16	1/4	1
1/2	28	62	133	23	51	109	56	120	260	43	93	200
3/4	62	134	290	50	110	230	120	260	560	93	200	420
1	120	260	a	100	210	a	240	500	a	180	390	800
1-1/4	250	540	a	200	440	a	500	1,060	a	380	800	a
1-1/2	380	810	a	310	660	a	750	1,600	a	570	1,210	a
2	750	1,590	a	610	1,300	a	1,470	3,100	a	1,120	2,350	a
2-1/2	1,200	2,550	a	980	2,100	a	2,370	5,000	a	1,800	3,780	a
3	2,160	a	a	1,760	3,710	a	4,230	a	a	3,200	6,710	a
4	4,460	a	a	3,640	7,630	a	8,730	a	a	6,620	a	a
6	13,200	a	a	10,800	a	a	25,900	a	a	19,600	a	a
8	27,400	a	a	22,400	a	a	53,400	a	a	40,500	a	a

* For these sizes and pressure losses the velocity is above 7,000 fpm. Select another combination of size and pressure loss. Reprinted by permission from ASHRAE Handbook - 1985 Fundamentals.



Useful Engineering Tables

Table CG-29. Schedule 40 Pipe, Standard Dimensions

Table with 15 columns: Size (in), Diameters (External, Approximate Internal), Nominal Thickness (in), Circumference (External, Internal), Transverse Areas (External, Internal, Metal), Length of Pipe Per sq ft (External Surface, Internal Surface), Length of Pipe Containing One Cubic Foot (Feet), Nominal Weight Per Foot (Plain Ends, Threaded and Coupled), Number of Threads Per Inch of Screw.

Table CG-30. Equivalent Length of Pipe to Be Added for Fittings—Schedule 40 Pipe

Table with 6 columns: Pipe Size (in), Standard Elbow, Side Outlet Tee, Gate Valve*, Globe Valve*, Angle Valve*.

Table CG-31. Thermal Expansion of Pipe

Table with 5 columns: Temp (°F), Cast Iron Pipe, Steel Pipe, Wrought Iron Pipe, Copper Pipe.

From Piping Handbook, by Walker and Crocker, by special permission. Table CG-31 gives the expansion from -20°F to temperature in question. To obtain the amount of expansion between any two temperatures, take the difference between the figures in the table for those temperatures. For example, if cast iron pipe is installed at a temperature of 80°F and is operated at 240°F, the expansion would be 1.780 - 0.649 = 1.131 in.

*Valve in full open position

Table CG-32. Diameters and Areas of Circles and Drill Sizes

Table with 12 columns: Drill Size, Diameter, Area, Drill Size, Diameter, Area, Drill Size, Diameter, Area, Drill Size, Diameter, Area.

Designs, materials, weights and performance ratings are approximate and subject to change without notice. Visit armstronginternational.com for up-to-date information.



Conversion Factors

Power		
Multiply	By	To Get
Boiler hp	33,472	Btu/hr
Boiler hp	34.5	lbs H ₂ O evap. at 212°F
Horsepower	2,540	Btu/hr
Horsepower	550	ft-lbs/sec
Horsepower	33,000	ft-lbs/min
Horsepower	42.42	Btu/min
Horsepower	0.7457	Kilowatts
Kilowatts	3,415	Btu/hr
Kilowatts	56.92	Btu/min
Watts	44.26	ft-lbs/min
Watts	0.7378	ft-lbs/sec
Watts	0.05692	Btu/min
Tons refriger.	12,000	Btu/hr
Tons refriger.	200	Btu/min
Btu/hr	0.00002986	Boiler hp
lbs H ₂ O evap. at 212°F	0.0290	Boiler hp
Btu/hr	0.000393	Horsepower
ft-lbs/sec	0.00182	Horsepower
ft-lbs/min	0.0000303	Horsepower
Btu/min	0.0236	Horsepower
Kilowatts	1.341	Horsepower
Btu/hr	0.000293	Kilowatts
Btu/min	0.01757	Kilowatts
ft-lbs/min	0.02259	Watts
ft-lbs/sec	1.355	Watts
Btu/min	1.757	Watts
Btu/hr	0.0000833	Tons Refrig.
Btu/min	0.005	Tons Refrig.

Energy		
Multiply	By	To Get
Btu	778	ft-lbs
Btu	0.000393	hp-hrs
Btu	0.000293	kw-hrs
Btu	0.0010307	{lbs H ₂ O evap.} at 212°F
Btu	0.293	Watt-hrs
ft-lbs	0.3765	Watt-hrs
latent heat} of ice	143.33	Btu/lb H ₂ O
lbs H ₂ O evap.} at 212°F	0.284	kw-hrs
lbs H ₂ O evap.} at 212°F	0.381	hp-hrs
ft-lbs	0.001287	Btu
hp-hrs	2,540	Btu
kw-hrs	3,415	Btu
lbs H ₂ O evap.} at 212°F	970.4	Btu
Watt-hrs	3.415	Btu
Watt-hrs	2,656	ft-lbs
Btu/lb H ₂ O	0.006977	{Latent heat of ice} {lbs H ₂ O evap. at 212°F}
kw-hrs	3.52	{lbs H ₂ O evap. at 212°F}
hp-hrs	2.63	{lbs H ₂ O evap. at 212°F}

Pressure		
Multiply	By	To Get
atmospheres	29.92	{in Mercury} (at 62°F)
atmospheres	406.8	{in H ₂ O} (at 62°F)
atmospheres	33.90	{ft. H ₂ O} (at 62°F)
atmospheres	14.70	lbs/in ²
atmospheres	1.058	ton/ft ²
in. H ₂ O} (at 62°F)	0.0737	{in. Mercury} (at 62°F)
ft H ₂ O} (at 62°F)	0.881	{in. Mercury} (at 62°F)
ft H ₂ O} (at 62°F)	0.4335	lbs/in ²
ft H ₂ O} (at 62°F)	62.37	lbs/ft ²
in. Mercury} (at 62°F)	70.73	lbs/ft ²
in. Mercury} (at 62°F)	0.4912	lbs/in ²
in. Mercury} (at 62°F)	0.03342	atmospheres
in. H ₂ O} (at 62°F)	0.002458	atmospheres
ft. H ₂ O} (at 62°F)	0.0295	atmospheres
lbs/in ²	0.0680	atmospheres
ton/ft ²	0.945	atmospheres
in. Mercury} (at 62°F)	13.57	{in. H ₂ O} (at 62°F)
in. Mercury} (at 62°F)	1.131	{ft H ₂ O} (at 62°F)
{ft H ₂ O} (at 62°F)	2.309	{ft H ₂ O} (at 62°F)
lbs/ft ²	0.01603	{in. Mercury} (at 62°F)
{in. Mercury} (at 62°F)	0.014138	{in Mercury} (at 62°F)
lbs/in ²	2.042	{at 62°F}
lbs/in ²	0.0689	Bar
lbs/in ²	0.0703	kg/cm ²

Velocity of Flow		
Multiply	By	To Get
ft/min	0.01139	miles/hr
ft/min	0.01667	ft/sec
cu ft/min	0.1247	gal/sec
cu ft/sec	448.8	gal/min
miles/hr	88	ft/min
ft/sec	60	ft/min
gal/sec	8.02	cu ft/min
gal/min	0.002228	cu ft/sec

Temperature	
°F = (°C x 1.8) + 32	
°C = (°F - 32) ÷ 1.8	

Weight		
Multiply	By	To Get
lbs	7,000	grains
lbs H ₂ O (60°F)	0.01602	cu ft H ₂ O (60°F)
lbs H ₂ O (60°F)	0.1198	gal H ₂ O (60°F)
tons (long)	2,240	lbs
tons (short)	2,000	lbs
grains	0.000143	lbs
lbs H ₂ O		
cu ft H ₂ O	62.37	(60°F)
lbs H ₂ O		
gal H ₂ O	8.3453	(60°F)
lbs	0.000446	tons (long)
lbs	0.000500	tons (short)

Circular Measure		
Multiply	By	To Get
Degrees	0.01745	Radians
Minutes	0.00029	Radians
Diameter	3.142	Circumference
Radians	57.3	Degrees
Radians	3.438	Minutes
Circumference	0.3183	Diameter

Volume		
Multiply	By	To Get
Barrels (oil)	42	gal (oil)
cu ft	1,728	cu in
cu ft	7.48	gal
cu in	0.00433	gal
gal (oil)	0.0238	barrels (oil)
cu in	0.000579	cu ft
gal	0.1337	cu ft
gal	231	cu in

Heat Transmission		
Multiply	By	To Get
Btu/in		{Btu/ft} /sq ft
/sq ft	0.0833	/hr/°F
/hr/°F		{Btu/in} /sq ft
Btu/ft		{Btu/in} /sq ft
/sq ft	12	/hr/°F
/hr/°F		{Btu/ft} /sq ft

Fractions and Decimals		
Multiply	By	To Get
Sixty-fourths	0.015625	Decimal
Thirty-seconds	0.03125	Decimal
Sixteenths	0.0625	Decimal
Eighths	0.125	Decimal
Fourths	0.250	Decimal
Halves	0.500	Decimal
Decimal	64	Sixty-fourths
Decimal	32	Thirty-seconds
Decimal	16	Sixteenths
Decimal	8	Eighths
Decimal	4	Fourths
Decimal	2	Halves

Gallons shown are U.S. standard.



Specific Heat—Specific Gravity

Table CG-33. Physical Properties of Liquids and Solids

	Liquid (L) or Solid (S)	sp gr @ 60-70°F	sp ht @ 60°F Btu/lb-°F
Acetic acid 100%	L	1.05	0.48
Acetic acid 10%	L	1.01	0.96
Acetone, 100%	L	0.78	0.514
Alcohol, ethyl, 95%	L	0.81	0.60
Alcohol, methyl, 90%	L	0.82	0.65
Aluminum	S	2.64	0.23
Ammonia, 100%	L	0.61	1.10
Ammonia, 26%	L	0.90	1.00
Aroclor	L	1.44	0.28
Asbestos board	S	0.88	0.19
Asphalt	L	1.00	0.42
Asphalt, solid	S	1.1-1.5	0.22-0.4
Benzene	L	0.84	0.41
Brickwork & Masonry	S	1.6-2.0	0.22
Brine - calcium chloride, 25%	L	1.23	0.689
Brine - sodium chloride, 25%	L	1.19	0.786
Clay, dry	S	1.9-2.4	0.224
Coal	S	1.2-1.8	0.26-0.37
Coal tars	S	1.20	0.35@40
Coke, solid	S	1.0-1.4	0.265
Copper	S	8.82	0.10
Cork	S	0.25	0.48
Cotton, cloth	S	1.50	0.32
Cottonseed oil	L	0.95	0.47
Dowtherm A	L	0.99	0.63
Dowtherm C	L	1.10	0.35-0.65
Ethylene glycol	L	1.11	0.58
Fatty acid - palmitic	L	0.85	0.653
Fatty acid - stearic	L	0.84	0.550
Fish, fresh, average	S		0.75-0.82
Fruit, fresh, average	S		0.80-0.88
Gasoline	L	0.73	0.53
Glass, Pyrex	S	2.25	0.20
Glass, wool	S	0.072	0.157
Glue, 2 parts water 1 part dry glue	L	1.09	0.89
Glycerol, 100% (glycerin)	L	1.26	0.58
Honey	L		0.34
Hydrochloric acid, 31.5% (muriatic)	L	1.15	0.60
Hydrochloric acid, 10% (muriatic)	L	1.05	0.75
Ice	S	0.90	0.50
Ice Cream	S		0.70
Lard	S	0.92	0.64
Lead	S	11.34	0.031
Leather	S	0.86-1.02	0.36
Linseed oil	L	0.93	0.44
Magnesia, 85%	L	0.208	0.27
Maple syrup	L		0.48
Meat, fresh, average	S		0.780
Milk	L	1.03	0.90-0.93
Nickel	S	8.90	0.11
Nitric acid, 95%	L	1.50	0.50
Nitric acid, 60%	L	1.37	0.64
Nitric acid, 10%	L	1.05	0.90
No. 1 Fuel Oil (kerosene)	L	0.81	0.47
No. 2 Fuel Oil	L	0.86	0.44
No. 3 Fuel Oil	L	0.88	0.43
No. 4 Fuel Oil	L	0.90	0.42
No. 5 Fuel Oil	L	0.93	0.41
No. 6 Fuel Oil	L	0.95	0.40

Table CG-33. (cont.) Physical Properties of Liquids and Solids

	Liquid (L) or Solid (S)	sp gr @ 60-70°F	sp ht @ 60°F Btu/lb-°F
API Mid-continent crude	L	.085	0.44
API gas oil	L	0.88	0.42
Paper	S	1.7-1.15	0.45
Paraffin	S	0.86-0.91	0.62
Paraffin, melted	L	0.90	0.69
Phenol (carbolic acid)	L	1.07	0.56
Phosphoric acid, 20%	L	1.11	0.85
Phosphoric acid, 10%	L	1.05	0.93
Phthalic anhydride	L	1.53	0.232
Rubber, vulcanized	S	1.10	0.415
SAE - SW (#8 machine lube oil)	L	0.88	
SAE - 20 (#20 machine lube oil)	L	0.89	
SAE - 30 (#30 machine lube oil)	L	0.89	
Sand	S	1.4-1.76	0.19
Sea water	L	1.03	0.94
Silk	S	1.25-1.35	0.33
Sodium hydroxide, 50% (caustic acid)	L	1.53	0.78
Sodium hydroxide, 30%	L	1.33	0.84
Soybean oil	L	0.92	0.24-0.33
Steel, mild @ 70	S	7.90	0.11
Steel, stainless, 300 series	S	8.04	0.12
Sucrose, 60% sugar syrup	L	1.29	0.74
Sucrose, 40% sugar syrup	L	1.18	0.66
Sugar, cane & beet	S	1.66	0.30
Sulfur	S	2.00	0.203
Sulfuric acid, 110% (fuming)	L		0.27
Sulfuric acid, 98%	L	1.84	0.35
Sulfuric acid, 60%	L	1.50	0.52
Sulfuric acid, 20%	L	1.14	0.84
Titanium (commercial)	S	4.50	0.13
Toluene	L	0.86	0.42
Trichloroethylene	L	1.62	0.215
Tetrachloride carbon	L	1.58	0.21
Turpentine, spirits of	L	0.86	0.42
Vegetables, fresh, average	S		0.73-0.94
Water	L	1.00	1.00
Wines, table, dessert, average	L	1.03	0.90
Woods, vary from	S	0.35-0.9	0.90
Wool	S	1.32	0.325
Zinc	S	7.05	0.095

Table CG-34. Physical Properties of Gases

	sp gr @ 60-70°F	spht@60°F Btu/lb-°F
Air	1.00	0.24
Ammonia	0.60	0.54
Benzene		0.325
Butane	2.00	0.455
Carbon dioxide	1.50	0.21
Carbon monoxide	0.97	0.255
Chlorine	2.50	0.118
Ethane	1.10	0.50
Ethylene	0.97	0.45
Freon - 12		0.16
Hydrogen	0.069	3.42
Hydrogen sulfide	1.20	0.25
Methane	0.55	0.60
Nitrogen	0.97	0.253
Oxygen	1.10	0.225
Propane	1.50	0.46
Sulfur dioxide		0.162
Water vapor (steam)	2.30	0.453

Designs, materials, weights and performance ratings are approximate and subject to change without notice. Visit armstronginternational.com for up-to-date information.



INTELLIGENT SOLUTIONS IN STEAM, AIR AND HOT WATER

Armstrong International

North America • Latin America • India • Europe / Middle East / Africa • China • Pacific Rim

armstronginternational.com